

Bethlehem ^{BG} PUMPING UNITS

PARTS LIST

160-173BG-86
160-212BG-86

INSTRUCTIONS FOR ORDERING PARTS

The following information must be furnished with all orders for BETHLEHEM BG Pumping Unit Parts:

1. Structural designation of Unit, e. g. 160-173BG-86
2. Serial Number of Unit (This number is stamped on gear box name plate.)

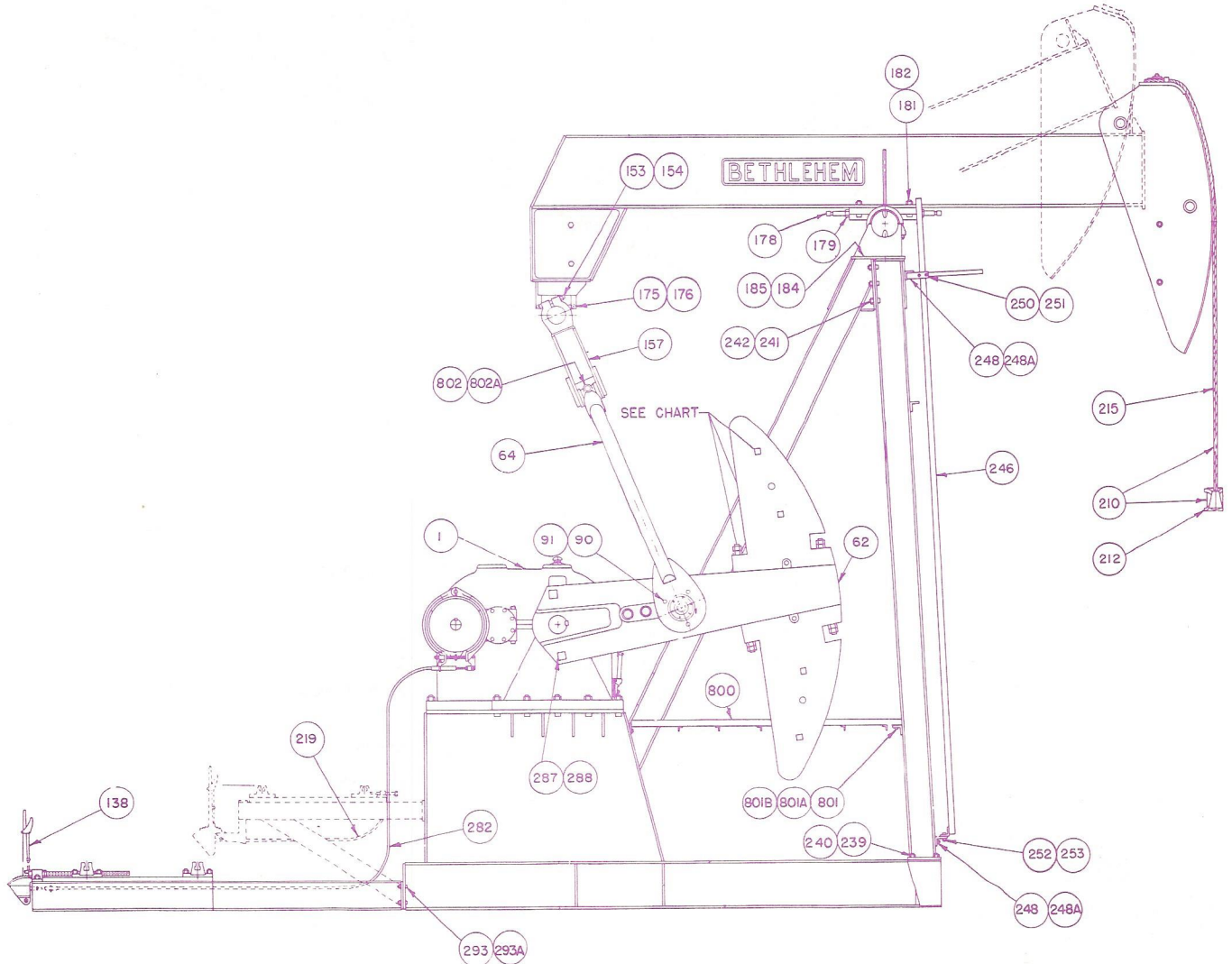

STRUCTURAL COMPONENTS

Item No.	Part No.	Description	No. Req'd.
1	DM 26888	Assembly, Reducer, 160 DA	1
62	DM 30323	Crank, 7478-B	2
64	BM 37682	Pitman, 6' - 0-5/8" Centers	2
90	907420	Screw, Cap, 3/4" x 2-1/2" (Pitman to Wrist Pin)	6
91	904114	Washer, Lock, 3/4" (Pitman to Wrist Pin)	6
153	902664	Bolt, Mach. w/Hex Nut 1" x 6-1/2" (Cross Beam to Tail Bearing)	2
154	904118	Washer, Lock, 1" (Cross Beam to Tail Bearing)	2
157	CM 35730	Cross Beam	1
175	902672	Bolt, Mach. w/Hex Nut 1" x 8-1/2" (Tail Bearing to Beam)	2
176	904118	Washer, Lock, 1" (Tail Bearing to Beam)	2
178	908350	Jack Screw (Adjusting Bolt, Beam) 1"x6" Cup Point Set Screw	2
179	935116	Nut, Hex Jam 1"	2
181	902654	Bolt, Mach. w/Hex Nut 1" x 4" (Saddle to Beam)	4
182	904118	Washer, Lock, 1" (Saddle to Beam)	4
184	902840	Bolt, Mach. w/Hex Nut 1-1/4" x 5-1/2" (Saddle Bearing to Post)	4
185		Washer, Lock, 1-1/4" (Saddle Bearing to Post)	4
210	BM 39152	Assembly, Wire Line	1
212	CM 10828	Carrier Bar	1
215		Wire Line, Size 1" x 23'- 0"	1
219	BP 13466	Brake Cable 8'-6" Elevated Electric Motor	1
239	902830	Bolt, Mach. w/Hex Nut 1-1/4" x 3" (Post to Base)	8
240	904122	Washer, Lock, 1-1/4"(Post to Base)	8
241	902642	Bolt, Mach. w/Hex Nut 1" x 2" (Rear to Front Post Leg)	12
242	904118	Washer, Lock, 1" (Rear to Front Post Leg)	12
246	CM 28333	Ladder	1
248	902462	Bolt, Mach. w/Hex Nut 3/4" x 2" (Ladder Bracket to Post)	3
248-A	904114	Washer, Lock, 3/4" (Ladder Bracket to Post)	3
250	902280	Bolt, Mach. w/Hex Nut 1/2" x 1-3/4" (Clamps Upper Ladder Bracket)	4
251	904108	Washer, Lock, 1/2" (Clamps Upper Ladder Bracket)	4
252	902276	Bolt, Mach. w/Hex Nut 1/2" x 1-1/4" (Ladder to Lower Bracket)	2
253	904108	Washer, Lock, 1/2" (Ladder to Lower Bracket)	2
256	902836	Bolt, Mach. w/Hex Nut, 1-1/4" x 4-1/2" (Reducer to Sub Base)	9
282	BP 13933	Brake Cable 14'-0", High Speed Engine	1
287	902848	Bolt, Mach, w/Hex Nut 1-1/4"x7-1/2"(Counterweight Stop)	4
288	904122	Washer, Lock, 1-1/4" (Counterweight Stop)	4
293	902464	Bolt, Mach. w/Hex Nut 3/4" x 2-1/4" (Base Joint)	4
293-A	904014	Washer, Cut, 3/4" (Base Joint)	8
800	CM 34408	Platform, Working	1
801	902370	Bolt, Mach. w/Hex Nut 5/8" x 1-3/4" (Working Platform)	4
801-A	904112	Washer, Lock, 5/8" (Working Platform)	4
801-B	904012	Washer, Cut, 5/8" (Working Platform)	4
802	902752	Bolt, Mach. w/Hex Nut 1-1/8" x 6" (Upper Pitman Connection)	2
802-A	904120	Washer, Lock, 1-1/8" (Upper Pitman Connection)	2

COUNTERWEIGHT BOLTS: QUANTITY, SIZE, PART NUMBER

Counter Weight	68R - DM 34662	50R - CM 34773
Size and Part Number	68L - DM 34663	50L - CM 34774
Quantity of Bolts	2 Bolts	2 Bolts
Bolt Size and Part Number	1-1/4" x 10" A-6816	1-1/4" x 7-1/2" A-5103

FILLERWEIGHT BOLTS: QUANTITY, SIZE, PART NUMBER

Filler Weight	68 DF-34688	50 CF-34775
Quantity of Bolts	2 Bolts	2 Bolts
Bolt Size and Part Number	1" x 10" A-34839	1" x 10" A-34839

Bethlehem ^{BG} PUMPING UNITS

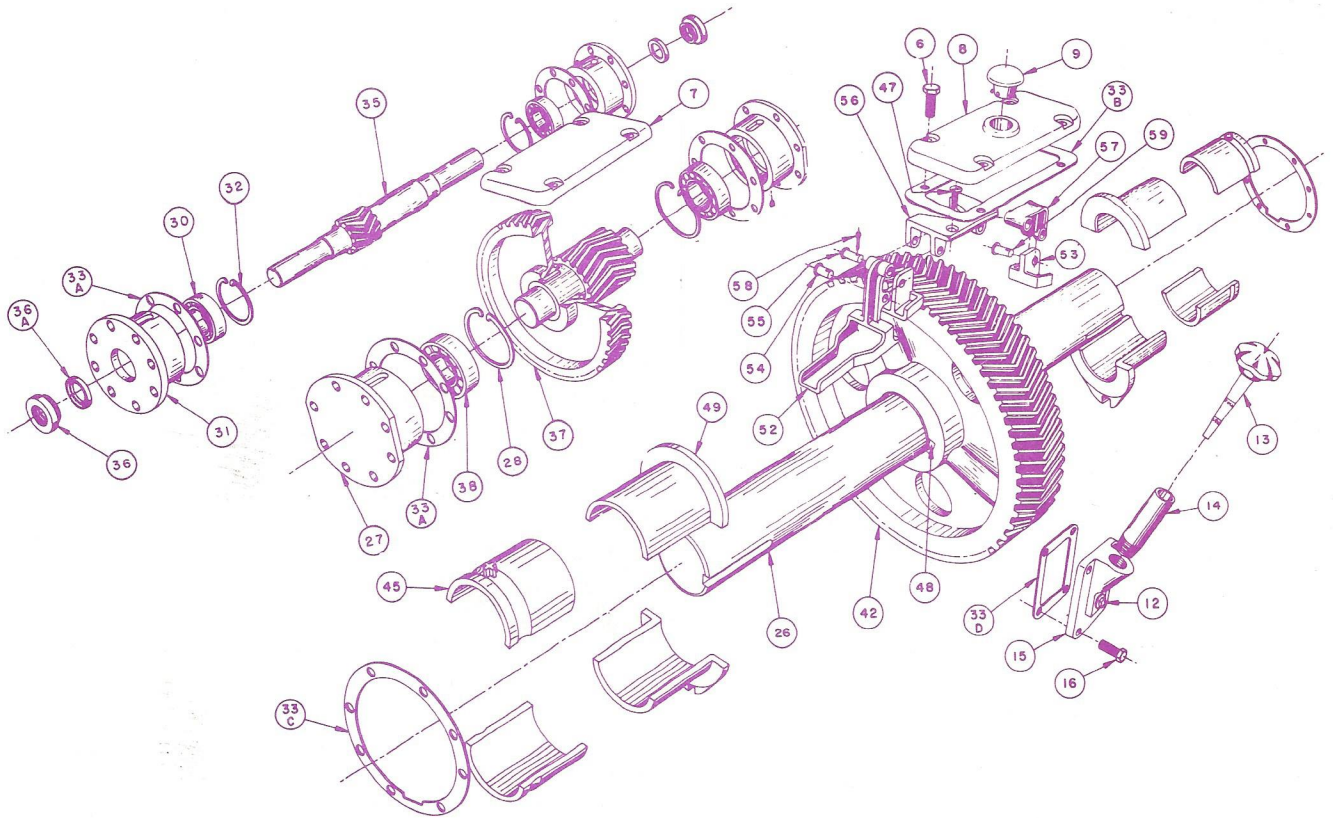

160DA GEAR REDUCER

Item No.	Part No.	Description	No. Req'd.	Item No.	Part No.	Description	No. Req'd.
6	907250	Cap Screw, Inspection Cover, 1/2 x 1-1/2"	8	36	AM 26860	Oil Seal, H. S. Shaft	2
7	AM 05031	Inspection Cover H. S. Shaft	1	36A	AP 26861	Slinger, H. S. Oil Seal	2
8	AM 05039	Inspection Cover L. S. Shaft	1	37	BM 05063	S. S. Pinion and H. S. Gear Assembly	1
9	AP 12944	Breather	1	38	952017	Bearing, S. S. Pinion	2
12	923810	Pipe Plug, Oil Drain, 1"	1	42	CM 08255	Slow Speed Gear	1
13	BP 08761	Oil Gage	1	45	BM 05048	Bronze Bushing, Crankshaft, Long	1
14	AM 09569	Pipe for Oil Gage	1	46	Not Used	Lock Washer, Oil Wiper	
15	AM 09901	Cover Plate, Oil Drain	1	47	913186	Cap Screw, Flat Head, Oil Wiper 1/2 x 1-1/4"	2
16	907250	Cap Screw, Cover Plate 1/2" x 1-1/4"	4	48	AM 05034	Key, S. S. Gear to Crankshaft	1
26	BM 05046	Crankshaft	1	49	BM 05047	Bronze Bushing, Crankshaft, Short	1
27	BM 08055	Bearing Carrier, S. S. Pinion	2	51	Not Used	Blade, Oil Wiper, See Item 53	
28	AP 06837	Snap Ring, S. S. Pinion Bearing Carrier	2	52	BM 05043	Spout, Oil Wiper (Integral with Hanger)	1
30	952015	Bearing, H. S. Pinion	2	53	AM 04716	Blade, Oil Wiper	2
31	BM 08058	Bearing Carrier, H. S. Pinion	2	54	Not Used		
32	AP 05024	Snap Ring, H. S. Pinion Bearing Carrier	2	55	AM 04667	Oil Wiper Pin, Hanger to Bracket	2
33	AM 10890	Gaskets for Gear Box, Set, Complete	1	56	AM 05030	Bracket, Oil Wiper	1
33A	AP 05164	Gasket, Bearing Carrier, H. S. Pin, S. S. Pin.	4	57	AM 05213	Hanger, Oil Wiper	1
33B	AP 05148	Gasket Inspection Covers	2	58	916046	Cotter, Oil Wiper Pins	4
33C	AP 05163	Gasket, Crankshaft Oil Seal	2	59	AM 05029	Oil Wiper Pin, Blade to Spout	1
33D	AP 09480	Gasket, Oil Drain Cover Plate	1	59A	AM 05022	Oil Wiper Pin, Blade (53) to Hanger (57) Not Shown	1
35	BM 08057	H. S. Pinion	1				

Bethlehem ^{BG} PUMPING UNITS

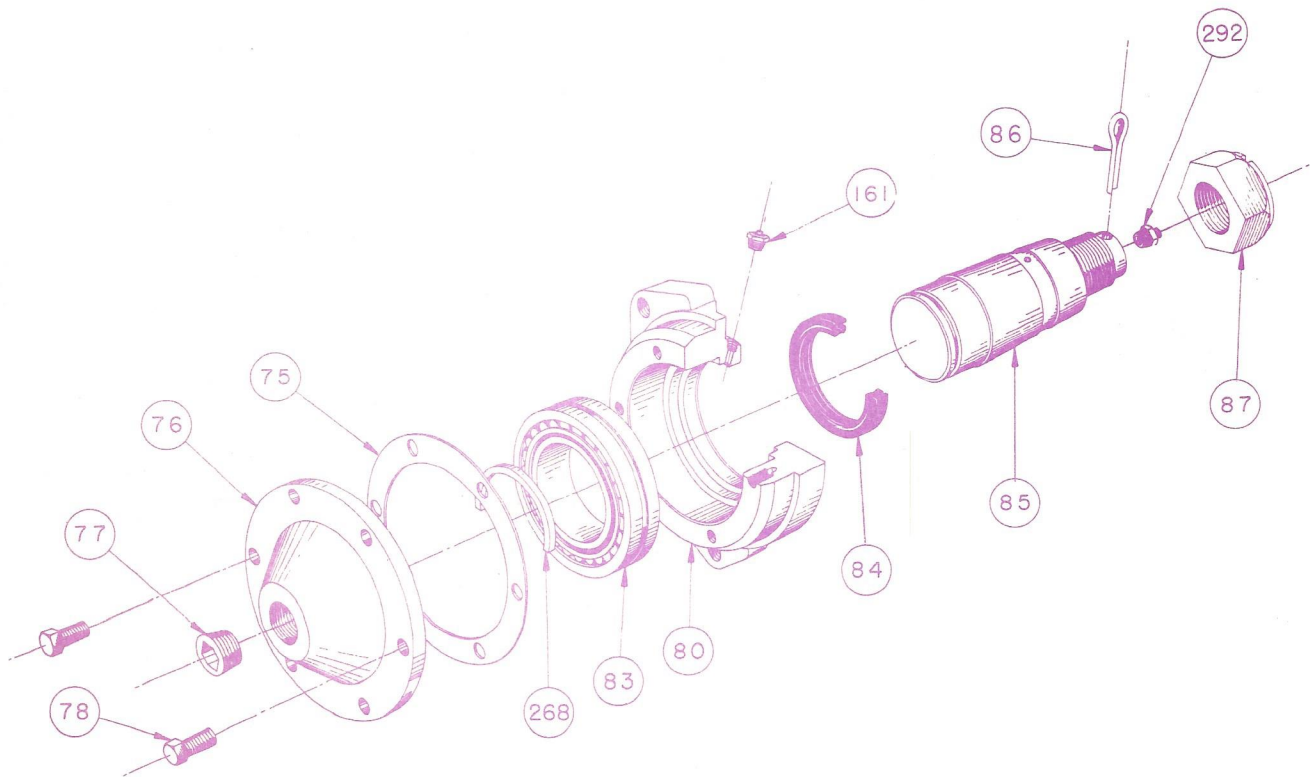

<u>Item No.</u>	<u>Part No.</u>	<u>Description</u>	<u>No. Req'd.</u>
	CM 34422	WRIST PIN BEARING ASSEMBLY #3SL	2
75	AP 15047	Gasket, W. P. Bearing Housing	2
76	CM 29054	Cap, Bearing	2
77	923907	Pipe Plug	2
78	907250	Cap Screw Hex Head	12
80	CM 29055	Housing, W. P. Bearing	2
83	AP 15499	Bearing, Spherical Roller	2
84	E 920415	Oil Seal	2
85	BM 34421	Wrist Pin	2
86	916268	Cotter Key	2
87	AM 05226	Nut, Wrist Pin	2
161	AP 34160	Alemite Relief Fitting 1/8" #317400	2
268	AP 28352	Snap Ring	2
292	AP 14327	Alemite Fitting	2

Bethlehem ^{BG} PUMPING UNITS

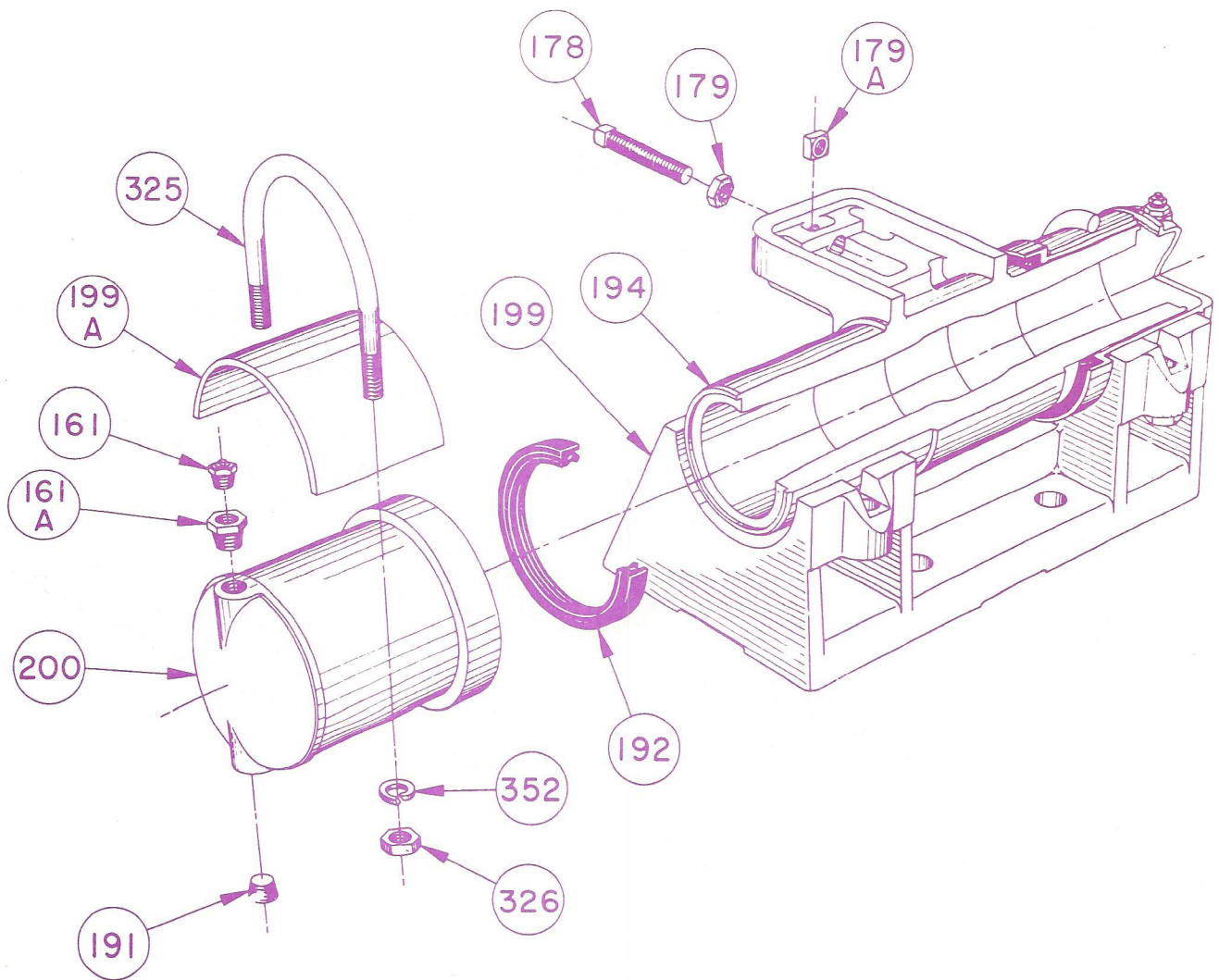

<u>Item No.</u>	<u>Part No.</u>	<u>Description</u>	<u>No. Req'd.</u>
	TM 06146	ASSEMBLY, SADDLE BEARING - #C-97	1
161	AP 34160	Alemite Relief Fitting, 1/8" #317400	2
161-A	925042	Pipe Bushing, 3/8" x 1/8"	2
178	N908350	Bolt, Adjusting 1" x 6" Cup Point Set Screw	2
179	935116	Nut, Hex Jam 1"	2
179-A	E-765004	Nut, Square 1"	2
191	927803	Pipe Plug, Flush 3/8"	2
192	SP 10809	Oil Seal	2
194	YM 60143	Saddle	1
199	YM 60980	Saddle Bearing Base	1
199-A	VM 60146	Saddle Bearing Cap	2
200	WM 60145	Bushing, Saddle	2
325	VM 60147	U-Bolt, 1"	2
326	903016	Nut, Hex 1"	4
352	904118	Lock Washer 1"	4

Bethlehem ^{BG} PUMPING UNITS

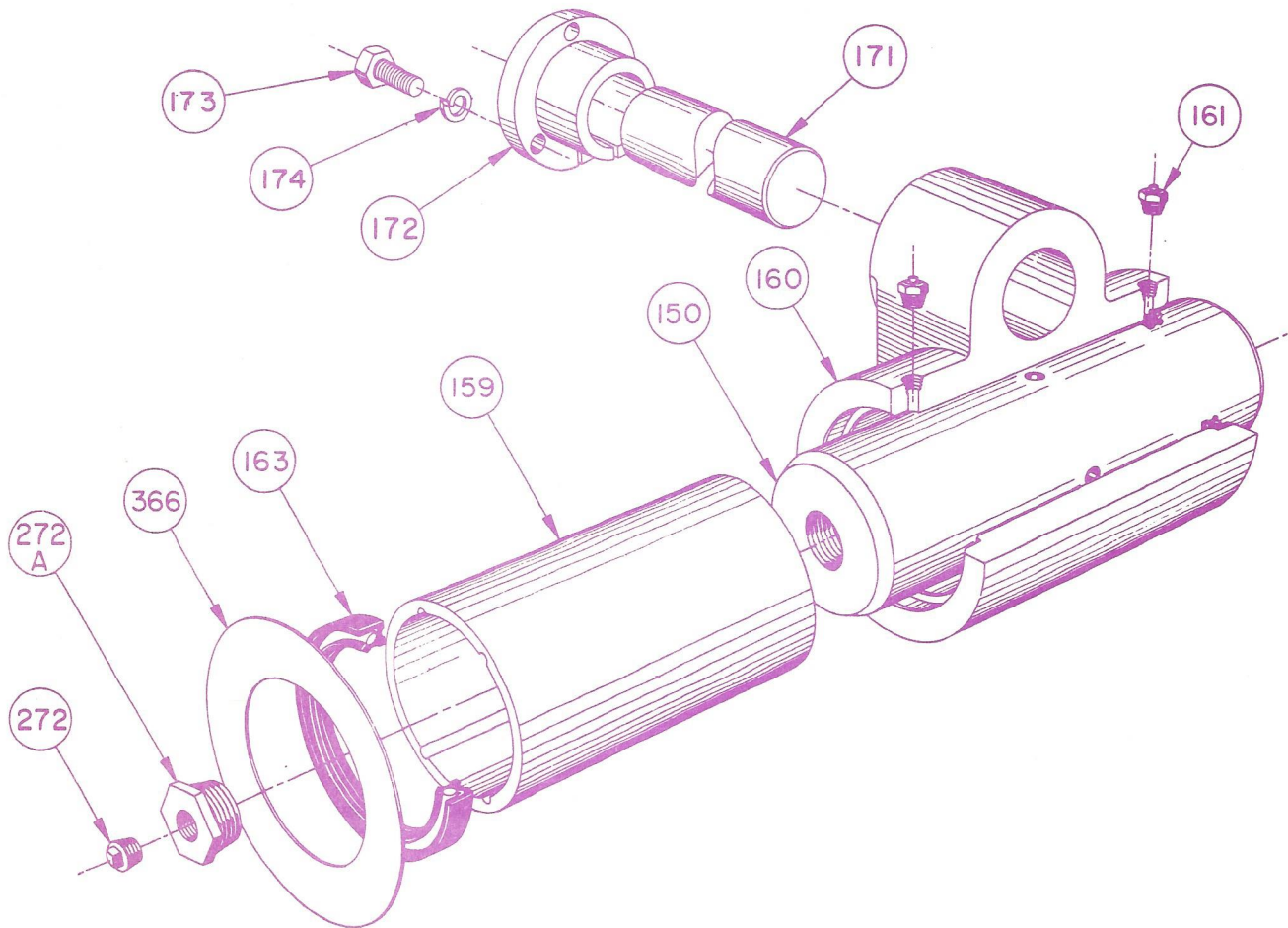

<u>Item No.</u>	<u>Part No.</u>	<u>Description</u>	<u>No. Req'd.</u>
		ASSEMBLY, EQUALIZER BEARING #E-37	1
150	BM 34440	Shaft, Equalizer Bearing	1
159	AM 34438	Bushing, Equalizer Bearing	1
160	BM 34439	Housing, Equalizer Bearing	1
161	AP 34160	Alemite Relief Fitting 1/8" #317400	2
163	E 920510	Oil Seal	2
171	AM 28305	Pin, Equalizer Bearing to Beam	1
172	AM 28311	Adjusting Bushing, Bearing to Beam	1
173	907416	Cap Screw, for Adj. Bushing	3
174	904114	Lockwasher	3
272	923802	Pipe Plug	1
272-A	925244	Pipe Bushing	1
366	JM 29408	Shim, Equalizer Bearing	2