

Bethlehem PUMPING UNITS

PARTS LIST

228-246-86

INSTRUCTIONS FOR ORDERING PARTS

The following information must be furnished with all orders for BETHLEHEM API Pumping Unit Parts:

1. Structural designation of Unit, e.g. 228-246-86
2. Serial Number of Unit (This number is stamped on gear box name plate.)

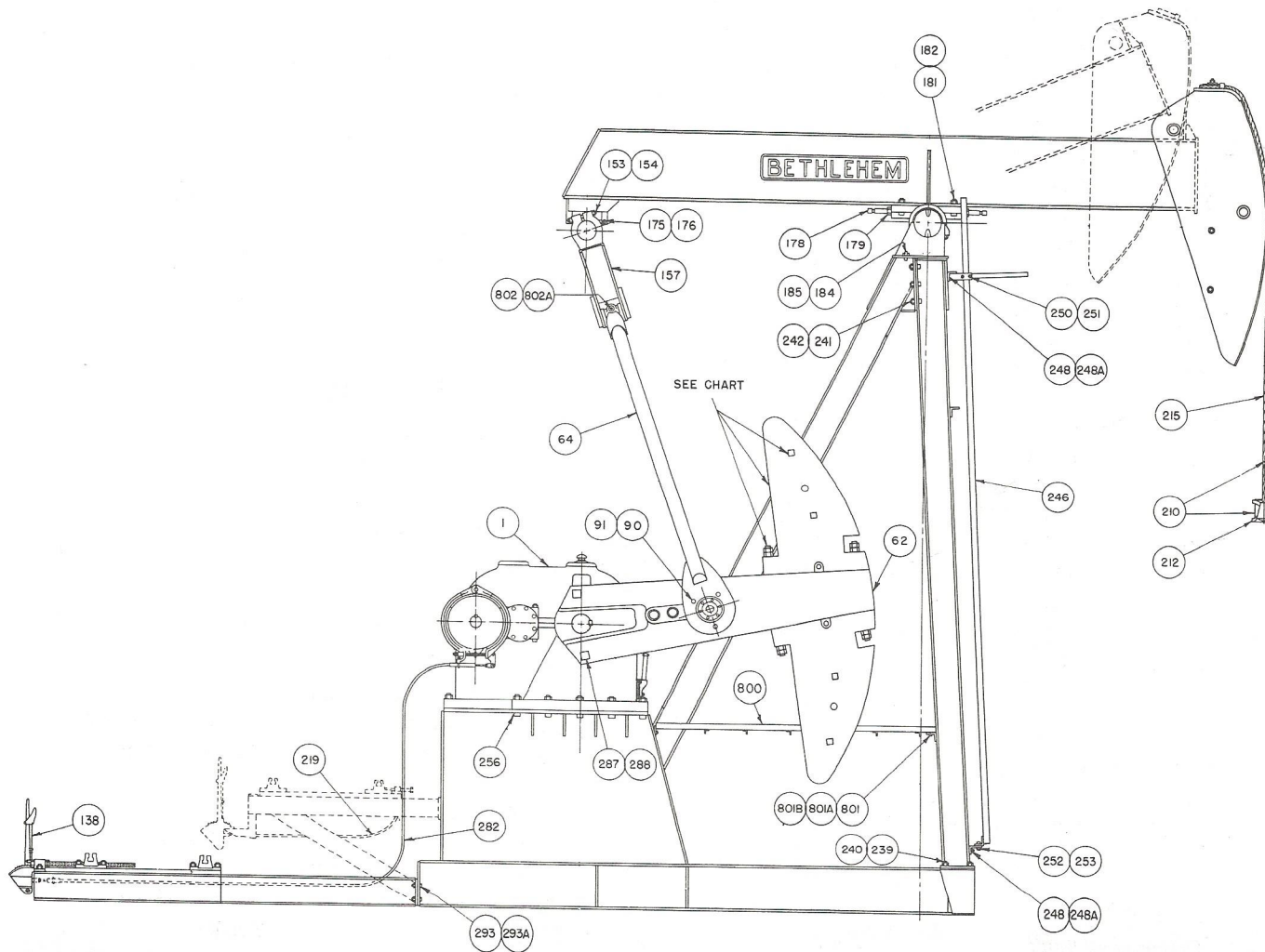

Bethlehem PUMPING UNITS

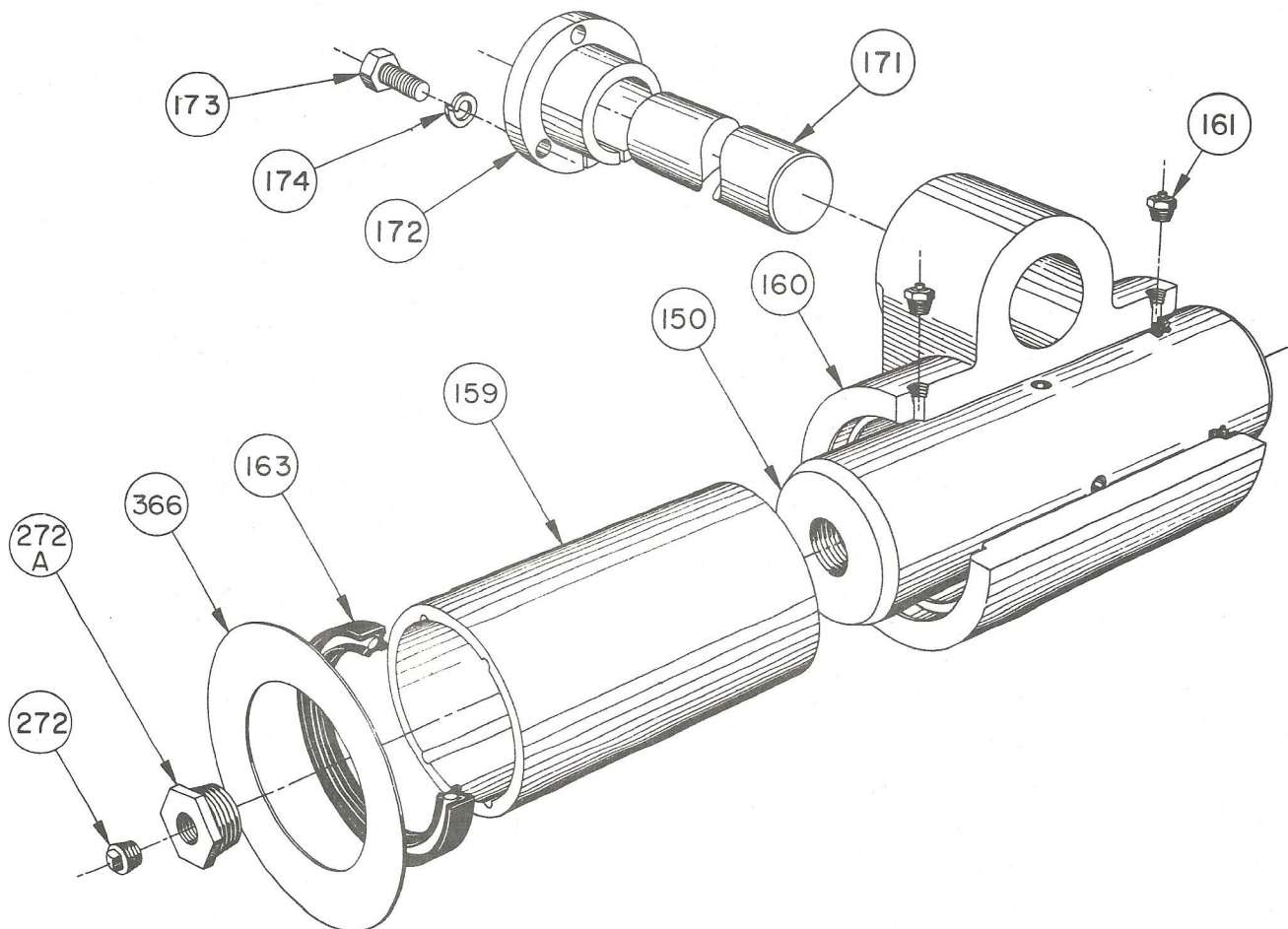

<u>Item No.</u>	<u>Part No.</u>	<u>Description</u>	<u>No. Req'd.</u>
		ASSEMBLY, EQUALIZER BEARING #E-37	1
150	BM 34440	Shaft, Equalizer Bearing	1
159	AM 34438	Bushing, Equalizer Bearing	1
160	BM 34439	Housing, Equalizer Bearing	1
161	AP 34160	Alemite Relief Fitting 1/8" #317400	2
163	E 920510	Oil Seal	2
171	AM 28305	Pin, Equalizer Bearing to Beam	1
172	AM 28311	Adjusting Bushing, Bearing to Beam	1
173	907416	Cap Screw, for Adj. Bushing	3
174	904114	Lockwasher	3
272	923802	Pipe Plug	1
272-A	925244	Pipe Bushing	1
366	AM 29408	Shim, Equalizer Bearing	1

Bethlehem PUMPING UNITS

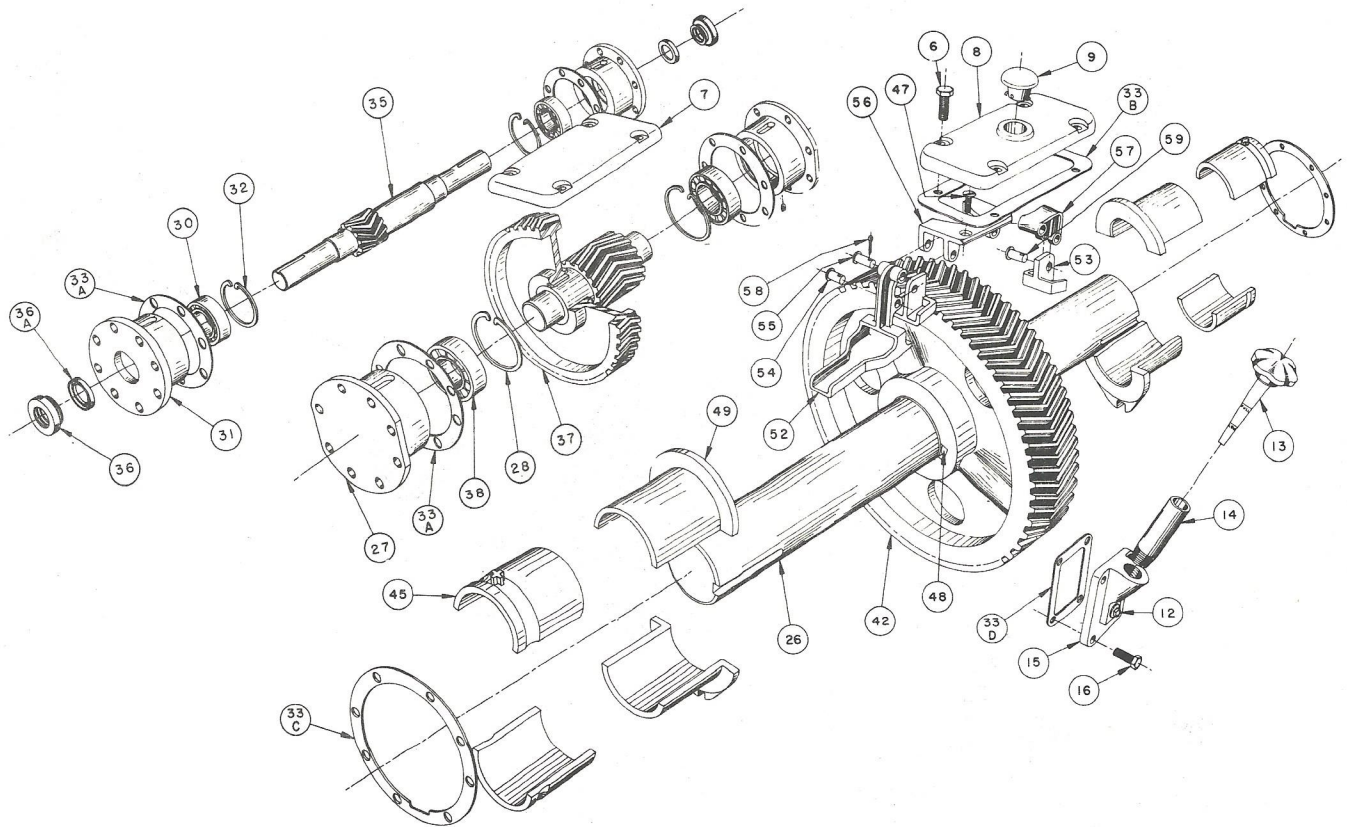

228DA GEAR REDUCER

Item No.	Part No.	Description	No. Req'd.	Item No.	Part No.	Description	No. Req'd.
6	907256	Cap Screw, 1/2" x 2" Inspection Covers	8	33D	APO9480	Gasket for Oil Drain Cover Plate	1
7	BM06612	Inspection Cover, H. S. Shaft	1	35	BM08095	High Speed Pinion	1
8	BM06618	Inspection Cover, L. S. Shaft	1	36	AM26863	Oil Seal, H. S. Shaft	2
9	AP12944	Breather	1	36A	AM26864	Slinger, H. S. Shaft	2
12	923810	Pipe Plug, Oil Drain	1	37	BM07931	S. S. Pinion and H. S. Gear Assembly	1
13	BP08761	Oil Gage	1	38	E952018	Roller Bearing, S. S. Pinion	2
14	AP09563	Pipe for Oil Gage	1	42	CM06622	Slow Speed Gear	1
15	AM09901	Cover Plate, Oil Drain	1	45	BM12423	Outer Bronze Bushing, Crankshaft	2
16	N907250	Cap Screw, 1/2" x 1-1/4", Oil Drain Plate	4	47	N907252	Cap Screw 1/2" x 1-1/2" Oil Wiper	2
26	BM06610	Crankshaft	1	48	AM06598	Key, S. S. Gear to Crankshaft	1
27	BM06617	Bearing Carrier, S. S. Pinion	2	49	BM12424	Inner Bronze Bushing, Crankshaft	2
28	AP06602	Snap Ring, S. S. Pin. Brg. Carrier	2	52	BM05043	Spout, Oil Wiper	1
30	E952016	Roller Bearing, H. S. Pinion	2	53	AM06604	Blade, Oil Wiper	2
31	BM08096	Bearing Carrier H. S. Pinion	2	54	AM05029	Pin, Oil Wiper, Spout to Blade	1
32	AP08024	Snap Ring, H. S. Brg. Carrier	2	55	AM04667	Pin, Oil Wiper, Hanger to Bracket	2
33	AM07933	Gaskets for Gear Box, Set	1	56	BM06616	Bracket, Oil Wiper	1
33A	AP05164	Gasket for Bearing Carrier	4	57	AM06605	Hanger, Oil Wiper	1
33B	AP06607	Gasket for Inspection Cover	2	58	916046	Cotter, 1/8" x 1", Oil Wiper Pins	4
33C	AP06606	Gasket for Crankshaft Oil Seal	2	59	AM05022	Pin, Oil Wiper, Blade to Hanger	1

STRUCTURAL COMPONENTS

Item No.	Part No.	Description	No. Req'd.
1	DM 26978	Assembly, Reducer, 228DA	1
62	DM 29025	Crank, 8495-B	2
64	BM 34533	Pitman, 8'-11-1/8" Centers	2
90	907420	Screw, Cap, 3/4" x 2-1/2" (Pitman to Wrist Pin)	6
91	904114	Washer, Lock, 3/4" (Pitman to Wrist Pin)	6
153	902672	Bolt, Mach. w/Hex Nut 1" x 8-1/2" (Cross Beam to Tail Bearing)	2
154	904118	Washer, Lock, 1" (Cross Beam to Tail Bearing)	2
157	CM 34546	Cross Beam	1
175	902672	Bolt, Mach. w/Hex Nut 1" x 8-1/2" (Tail Bearing to Beam)	2
176	904118	Washer, Lock, 1" (Tail Bearing to Beam)	2
178	VM 12425	Jack Screw (Adjusting Bolt, Beam)	2
179	903120	Nut, Hex Jam 1-1/4"	2
181	902838	Bolt, Mach. w/Hex Nut 1-1/4" x 5" (Saddle to Beam)	4
182	904122	Washer, Lock 1-1/4" (Saddle to Beam)	4
184	902932	Bolt, Mach. w/Hex Nut 1-1/2" x 6" (Saddle Bearing to Post)	4
185	904124	Washer, Lock, 1-1/2" (Saddle Bearing to Post)	4
210	BM-30336	Assembly, Wire Line	1
212	CM 10823	Carrier Bar	1
215		Wire Line, Size 1-1/8" x 29'-0"	1
219	BP 13467	Brake Cable 10'-6", Elevated Electric Motor	1
239	902830	Bolt, Mach. w/Hex Nut 1-1/4" x 3" (Post to Base)	12
240	904122	Washer, Lock, 1-1/4" (Post to Base)	12
241	902644	Bolt, Mach. w/Hex Nut 1" x 2-1/4" (Rear to Front Post Leg)	12
242	904118	Washer, Lock, 1" (Rear to Front Post Leg)	12
246	BM-29709	Ladder	1
248	902462	Bolt, Mach. w/Hex Nut 3/4" x 2" (Ladder Bracket to Post)	3
248-A	904114	Washer, Lock, 3/4" (Ladder Bracket to Post)	3
250	902286	Bolt, Mach. w/Hex Nut 1/2" x 2-1/2" (Clamps, Upper Ladder Bracket)	4
251	904108	Washer, Lock, 1/2" (Clamps, Upper Ladder Bracket)	4
252	902276	Bolt, Mach. w/Hex Nut 1/2" x 1-1/4" (Ladder to Lower Bracket)	2
253	904108	Washer Lock 1/2" (Ladder to Lower Bracket)	2
256	902838	Bolt, Mach. w/Hex Nut, 1-1/4" x 5" (Reducer to Sub Base)	12
282	BP 13933	Brake Cable 14'-0", High Speed Engine	1
287	902940	Bolt, Mach. w/Hex Nut 1-1/2" x 8" (Counterweight Stop)	4
288	904124	Washer, Lock, 1-1/2" (Counterweight Stop)	4
293	902464	Bolt, Mach. w/Hex Nut 3/4" x 2-1/4" (Base Joint)	4
293-A	904014	Washer, Cut 3/4" (Base Joint)	8
800	CM 34196	Platform, Working	1
801	902370	Bolt, Mach. w/Hex Nut 5/8" x 1-3/4" (Working Platform)	4
801-A	904112	Washer, Lock, 5/8" (Working Platform)	4
801-B	904012	Washer, Cut, 5/8" (Working Platform)	4
802	902752	Bolt, Mach. w/Hex Nut 1-1/8" x 6" (Upper Pitman Connection)	2
802-A	904120	Washer, Lock, 1-1/8" (Upper Pitman Connection)	2

COUNTERWEIGHT BOLTS: QUANTITY, SIZE, PART NUMBER

Counter Weight	78R - DM 34706	68R - DM 3466Z	50R - CM 34773
Size and Part Number	78L - DM 34707	68L - DM 34663	50L - CM 34774
Quantity of Bolts	2 Bolts	2 Bolts	2 Bolts
Bolt Size and Part Number	1-1/4" x 11" A-5051	1-1/4" x 11" A-5051	1-1/4" x 8" A-22847

FILLERWEIGHT BOLTS: QUANTITY, SIZE, PART NUMBER

Filler Weight	78 CF-34708	68 DF-34688	50 CF-34775
Quantity of Bolts	2 Bolts	2 Bolts	2 Bolts
Bolt Size and Part Number	1" x 10" A-34839	1" x 10" A-34839	1" x 10" A-34839

Bethlehem PUMPING UNITS

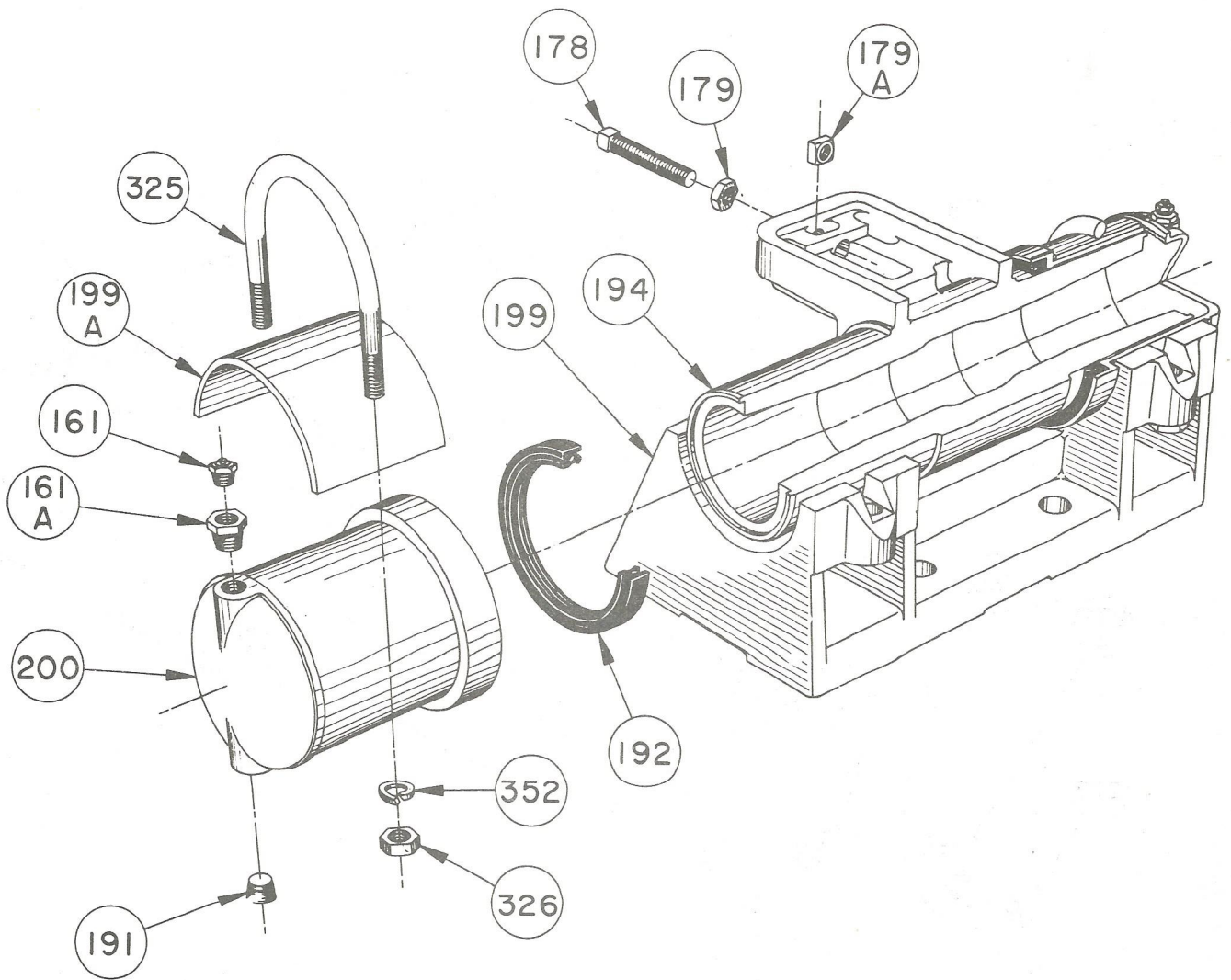

<u>Item No.</u>	<u>Part No.</u>	<u>Description</u>	<u>No. Req'd.</u>
		ASSEMBLY, SADDLE BEARING - #C125	1
161	AP34160	Alemite Relief Fitting, 1/8" #317400	2
161-A	925042	Pipe Bushing, 3/8" x 1/8"	2
178	VM 12425	Bolt, Adjusting 1-1/4" x 8"	2
179	903120	Nut, Hex Jam 1-1/4"	2
179-A	E 765032	Nut, Square 1-1/4"	2
191	923903	Pipe Plug, Flush 3/8"	2
192	920900	Oil Seal, 9-1/2" OD x 8" ID x 3/4"	4
194	YM 60402	Saddle	1
199	XM 60395	Saddle Bearing Base	1
199-A	VM 60392	Saddle Bearing Cap	2
200	XM 60397	Bushing, Saddle	2
325	VM 60393	U-Bolt 1-1/4"	2
326	903020	Nut, Hex 1-1/4"	4
352	904122	Lock Washer 1-1/4"	4

Bethlehem PUMPING UNITS

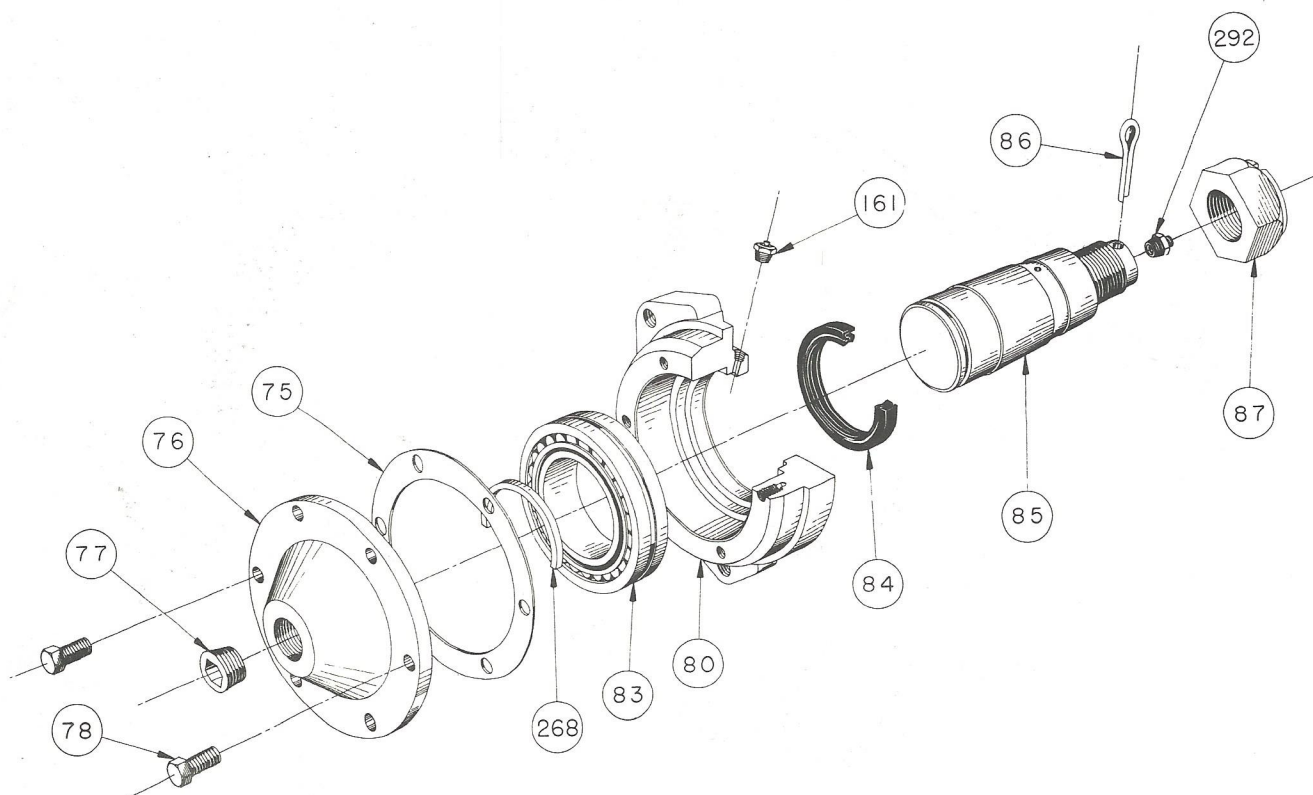

<u>Item No.</u>	<u>Part No.</u>	<u>Description</u>	<u>No. Req'd.</u>
	CM 34422	WRIST PIN BEARING ASSEMBLY #3SL	2
75	AP 15047	Gasket, W. P. Bearing Housing	2
76	CM 29054	Cap, Bearing	2
77	923907	Pipe Plug	2
78	907250	Cap Screw Hex Head	12
80	CM 29055	Housing, W. P. Bearing	2
83	AP 15499	Bearing, Spherical Roller	2
84	E 920415	Oil Seal	2
85	BM 34421	Wrist Pin	2
86	916268	Cotter Key	2
87	AM 05226	Nut, Wrist Pin	2
161	AP 34160	Alemite Relief Fitting 1/8" #317400	2
268	AP 28352	Snap Ring	2
292	AP 14327	Alemite Fitting	2