

Bethlehem ^{BG} PUMPING UNITS

PARTS LIST

640-304BG-144

INSTRUCTIONS FOR ORDERING PARTS

The following information must be furnished with all orders for BETHLEHEM BG Pumping Unit Parts:

1. Structural designation of Unit, e. g., 640-304BG-144
2. Serial Number of Unit (This number is stamped on gear box name plate.)

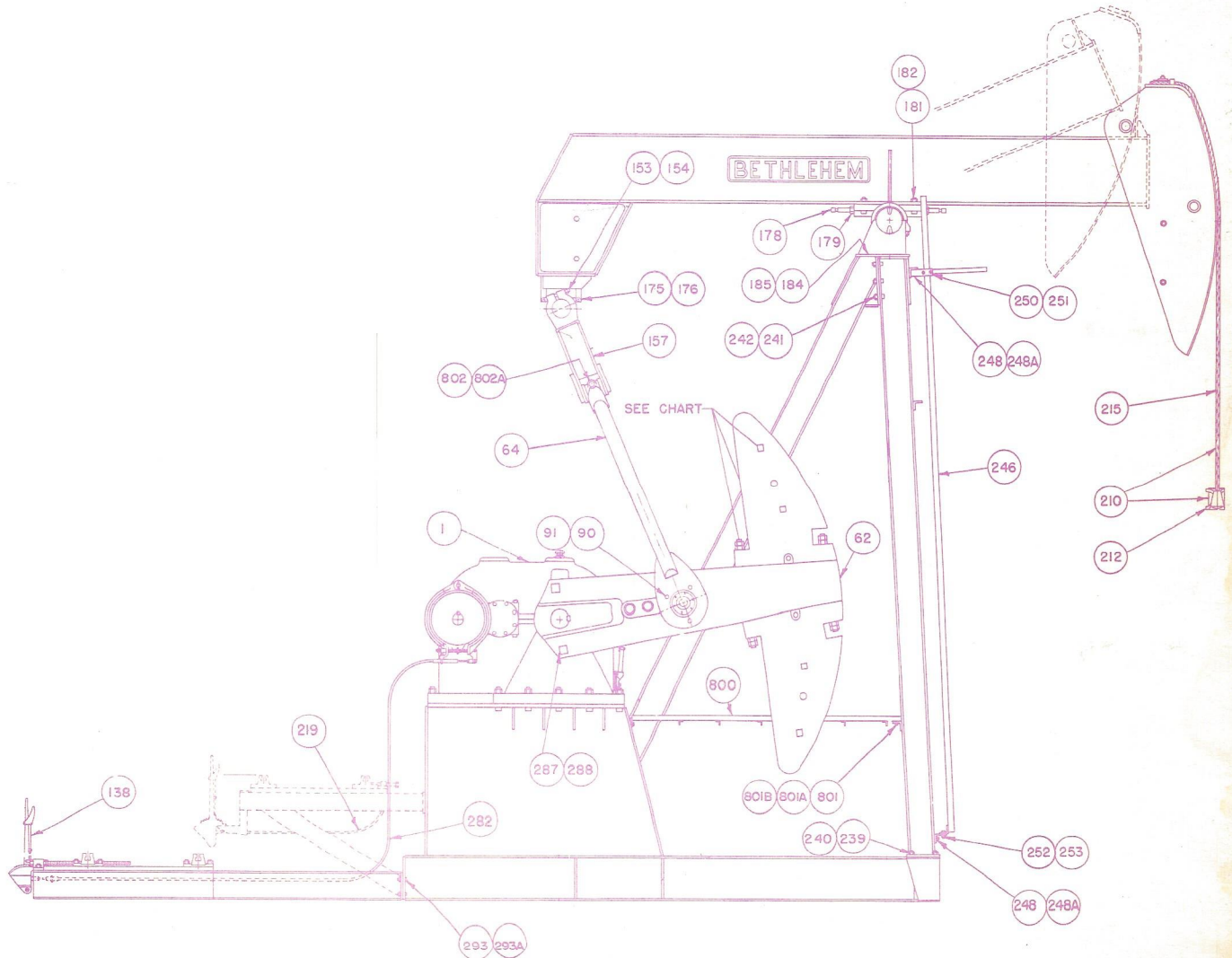

STRUCTURAL COMPONENTS

Item No.	Part No.	Description	No. Req'd.
1	DM 27102	Assembly, Reducer, 640DC	1
62	CM-38888	Crank, 82110B	2
64	BM-38936	Pitman, 8' - 8-1/4" Centers	2
90	907504	Screw, Cap, 7/8" x 3" (Pitman to Wrist Pin)	6
91	904116	Washer, Lock, 7/8" (Pitman to Wrist Pin)	6
153	902672	Bolt, Mach. w/Hex Nut 1" x 8-1/2" (Cross Beam to Tail Bearing)	2
154	904118	Washer, Lock, 1" (Cross Beam to Tail Bearing)	2
157	CM-36207	Cross Beam	1
175	902854	Bolt, Mach. w/Hex Nut 1-1/4" x 9" (Tail Bearing to Beam)	2
176	904122	Washer, Lock, 1-1/4" (Tail Bearing to Beam)	2
178	VM 12425	Jack Screw (Adjusting Bolt, Beam)	2
179	903120	Nut, Hex Jam 1-1/4"	2
181	902838	Bolt, Mach. w/Hex Nut 1-1/4" x 5" (Saddle to Beam)	4
182	904122	Washer, Lock 1-1/4" (Saddle to Beam)	4
184	902932	Bolt, Mach. w/Hex Nut 1-1/2" x 6" (Saddle Bearing to Post)	4
185	904124	Washer, Lock, 1-1/2" (Saddle Bearing to Post)	4
210	BM 31615	Assembly, Wire Line	1
212	CM 32275	Carrier Bar	1
215		Wire Line, Size 1-1/4" x 35'-0"	1
219	BP 13934	Brake Cable 12'-0", Elevated Electric Motor	1
239	902831	Bolt, Mach. w/Hex Nut 1-1/4" x 3-1/4" (Post to Base)	12
240	904122	Washer, Lock, 1-1/4" (Post to Base)	12
241	902644	Bolt, Mach. w/Hex Nut 1" x 2-1/4" (Rear to Front Post Leg)	16
242	904118	Washer, Lock, 1" (Rear to Front Post Leg)	16
246	BM 36410	Ladder	1
248	902462	Bolt, Mach. w/Hex Nut 3/4" x 2" (Ladder Bracket to Post)	3
248-A	904114	Washer, Lock, 3/4" (Ladder Bracket to Post)	3
250	902286	Bolt, Mach. w/Hex Nut 1/2" x 2-1/2" (Clamps Upper Ladder Bracket)	4
251	904108	Washer, Lock, 1/2" (Clamps Upper Ladder Bracket)	4
252	902276	Bolt, Mach. w/Hex Nut 1/2" x 1-1/4" (Ladder to Lower Bracket)	2
253	904108	Washer Lock 1/2" (Ladder to Lower Bracket)	2
256	902840	Bolt, Mach. w/Hex Nut, 1-1/4" x 5-1/2" (Reducer to Sub Base)	12
282	BP 27209	Brake Cable 16'-0", High Speed Engine	1
287	902944	Bolt, Mach. w/Hex Nut 1-1/2" x 9" (Counterweight Stop)	4
288	904124	Washer, Lock, 1-1/2" (Counterweight Stop)	4
293	902464	Bolt, Mach. w/Hex Nut 3/4" x 2-1/4" (Base Joint)	4
293-A	904014	Washer, Cut 3/4" (Base Joint)	8
800	CM 36201	Platform, Working	1
801	902370	Bolt, Mach. w/Hex Nut 5/8"x1-3/4" (Working Platform to Post)	2
801	902372	Bolt, Mach. w/Hex Nut 5/8" x 2" (Working Platform to Sub Base)	2
801-A	904112	Washer, Lock, 5/8" (Working Platform)	4
801-B	904012	Washer, Cut, 5/8" (Working Platform)	4
802	902848	Bolt, Mach. w/Hex Nut 1-1/4" x 7-1/2" (Upper Pitman Connection)	2
802-A	904122	Washer, Lock, 1-1/4" (Upper Pitman Connection)	2

COUNTERWEIGHT BOLTS: QUANTITY, SIZE, PART NUMBER

Counter Weight	95R - DM 34297	78R - DM 34706
Size and Part Number	95L - DM 34449	78L - DM 34707
Quantity of Bolts	2 Bolts	2 Bolts
Bolt Size and Part Number	1-1/2" x 11-1/2" A-6672	1-1/4" x 11" A-5051

FILLERWEIGHT BOLTS: QUANTITY, SIZE, PART NUMBER

Filler Weight	95 CF-34303	78 CF-34708
Quantity of Bolts	2 Bolts	2 Bolts
Bolt Size and Part Number	1" x 10" A-34839	1" x 10" A-34839

Bethlehem BG PUMPING UNITS

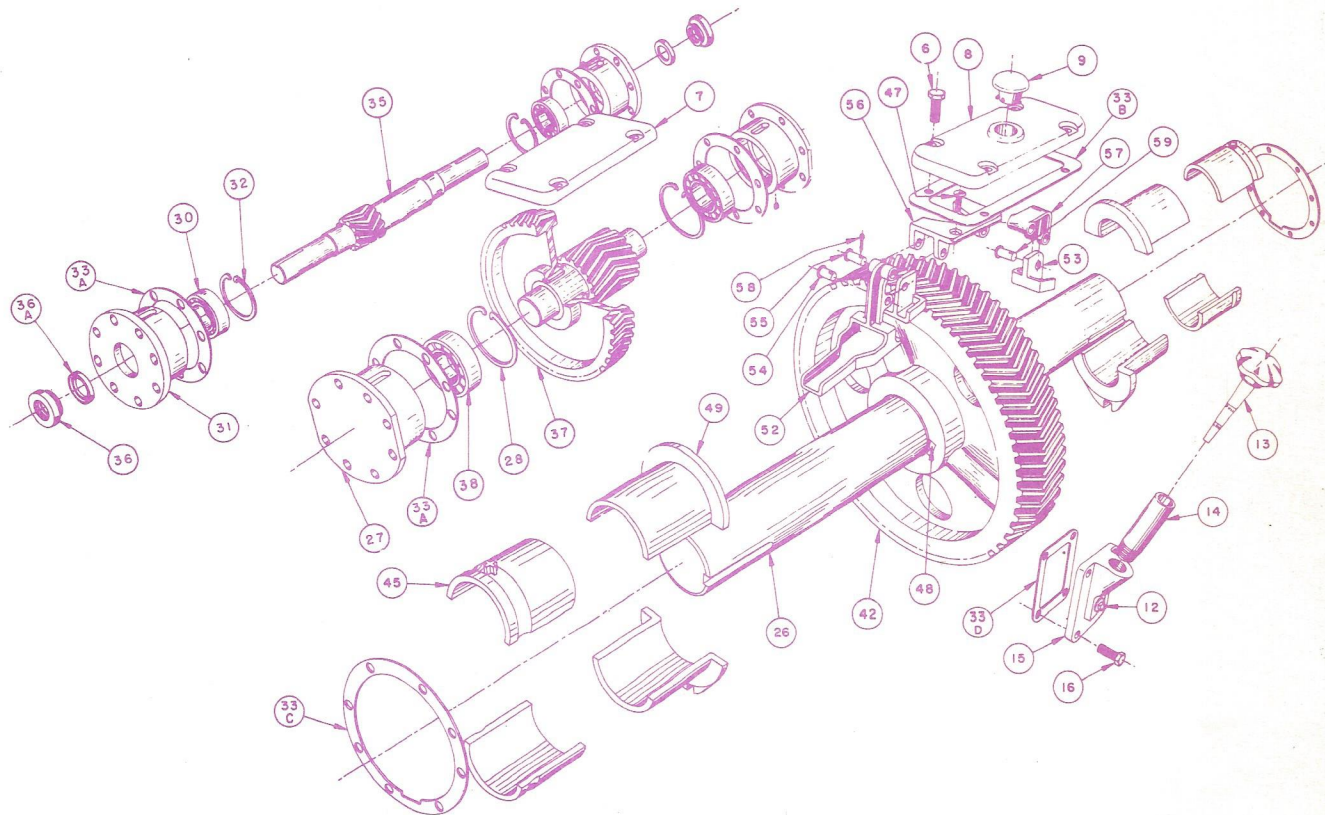

640DC GEAR REDUCER

Item No.	Part No.	Description	No. Req'd.	Item No.	Part No.	Description	No. Req'd.
6	907254	Cap Screw, Inspection Cover 1/2" x 1-3/4"	8	33D	AP 09480	Gasket, Oil Drain Cover Plate	1
7	BM 08551	Inspection Cover H. S. Shaft	1	35	BM 09762	High Speed Pinion	1
8	BM 15438	Inspection Cover L. S. Shaft	1	36	AM 27043	Oil Seal, H. S. Shaft	2
9	AP 12944	Breather	1	36A	AP 27044	Slinger, H. S. Oil Seal	2
12	923810	Pipe Plug, Oil Drain (1" Sq. Hd.)	1	37	CM 09747	S. S. Pinion and H. S. Gear Assembly	1
13	BP 08761	Oil Gage	1	38	952026	Bearing, S. S. Pinion	2
14	AM 09557	Pipe for Oil Gage	1	42	CM 09746	Slow Speed Gear	1
15	AM 09901	Cover Plate, Oil Drain	1	45	BM 08575	Outer Bronze Bushing, Crankshaft,	2
16	907250	Cap Screw, Cover Plate 1/2" x 1-1/4"	4	46	904108	Lock Washer, Oil Wiper, 1/2" Not Shown(w/47)	2
26	BM 09738	Crankshaft	1	47	907250	Cap Screw, Oil Wiper 1/2" x 1-1/4"	2
27	BM 08059	Bearing Carrier, S. S. Pinion	2	48	AM 09731	Key, S.S. Gear to Crankshaft	1
28	AP 06873	Snap Ring, S. S. Pinion Bearing Carrier	2	49	AM 08576	Inner Bronze Bushing, Crankshaft	2
30	952024	Bearing, H. S. Pinion	2	52	Not Used	Spout, Oil Wiper	2
31	BM 09739	Bearing Carrier, H. S. Pinion	2	53	AM 20852	Blade, Oil Wiper	2
32	AP 09654	Snap Ring, H. S. Pinion Bearing Carrier	2	54	AP 05022	Oil Wiper Pin, Blade to Hanger	2
33	AM 15467	Gaskets for Gear Box, Set Complete	1	55	AP 04667	Oil Wiper Pin, Hanger to Bracket	2
33A	AP 08565	Gasket, Bearing Carrier, H. S. Pinion, S. S. Pinion	4	56	BM 15440	Bracket, Oil Wiper	1
33B	AP 08564	Gasket, Inspection Cover, L. S. Shaft	1	57	AM 06626	Hanger, Oil Wiper	2
33B	AP 15441	Gasket, Inspection Cover, H. S. Shaft	1	58	916046	Cotter, 1/8" x 1", Oil Wiper Pins	4
33C	AP 09653	Gasket, Crankshaft Oil Seal	2	59	Not Used	Oil Wiper Pin, Blade to Hanger(Same as 54)	4

Bethlehem ^{BG} PUMPING UNITS

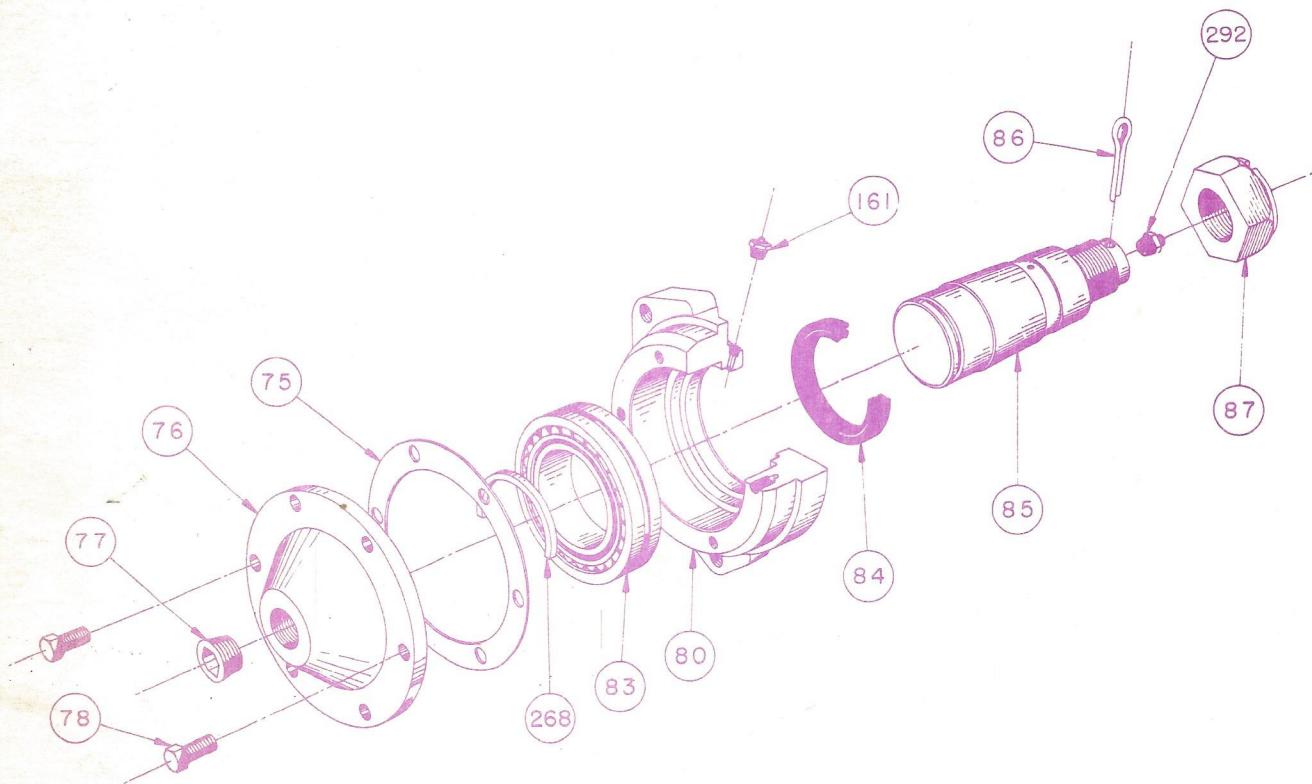

<u>Item</u> <u>No.</u>	<u>Part</u> <u>No.</u>	<u>Description</u>	<u>No.</u> <u>Req'd.</u>
	CM 36072	WRIST PIN BEARING ASSEMBLY #1SL	2
75	AP 29363	Gasket, W. P. Bearing Housing	2
76	CM 29366	Cap, Bearing	2
77	923907	Pipe Plug	2
78	907250	Cap Screw Hex Head	12
80	CM 29365	Housing, W. P. Bearing	2
83	AP 15502	Bearing, Spherical Roller	2
84	920590	Oil Seal	2
85	BM 36061	Wrist Pin	2
86	916270	Cotter Key	2
87	AM 12-55	Nut, Wrist Pin	2
161	AP 04811	Alemite Relief Fitting	2
268	AP 15502	Snap Ring	2
292	AP 14327	Alemite Fitting	2

Bethlehem ^{BG} PUMPING UNITS

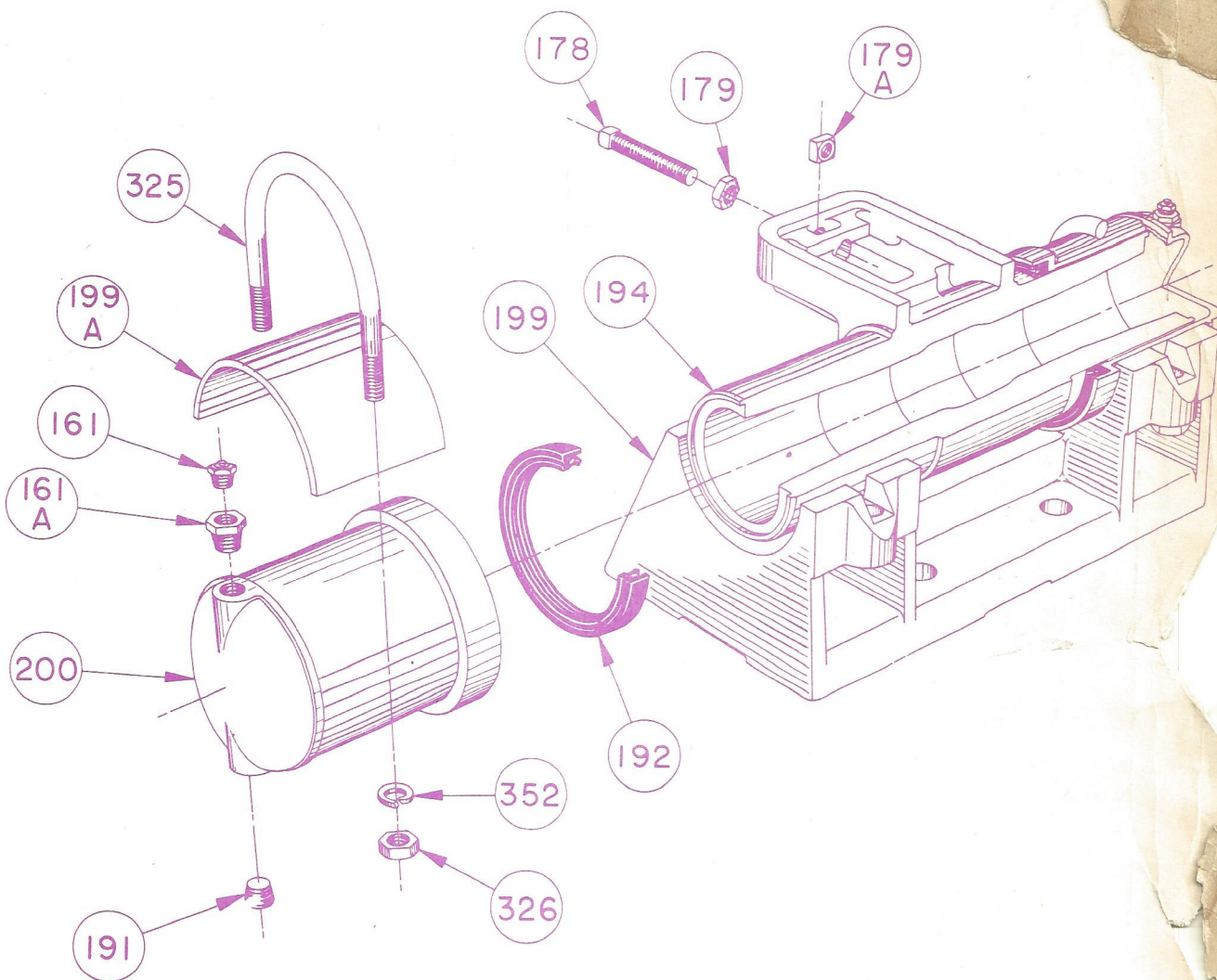

<u>Item No.</u>	<u>Part No.</u>	<u>Description</u>	<u>No. Req'd.</u>
	TM 06251	ASSEMBLY, SADDLE BEARING #C-150	1
161	AP 34160	Alemite Relief Fitting, 1/8" #317400	2
161-A	925042	Pipe Bushing, 3/8" x 1/8"	2
178	VM 12425	Bolt, Adjusting 1-1/4" x 8"	2
179	903120	Nut, Hex Jam, 1-1/4"	2
179-A	E 765032	Nut, Square, 1-1/4"	2
191	923930	Pipe Plug, Flush, 3/8"	2
192	920960	Oil Seal, 10-3/4" OD x 8-3/4" ID x 3/4" wide	4
194	YM 60860	Saddle	1
199	DM 36243	Saddle Bearing Base	1
199-A	AM 36180	Saddle Bearing Cap	2
200	XM 60862	Bushing, Saddle	2
325	AM 36216	U-Bolt 1-1/4"	2
326	903020	Nut, Hex, 1-1/4"	4
352	904122	Lock Washer 1-1/4"	4

Bethlehem ^{BG} PUMPING UNITS

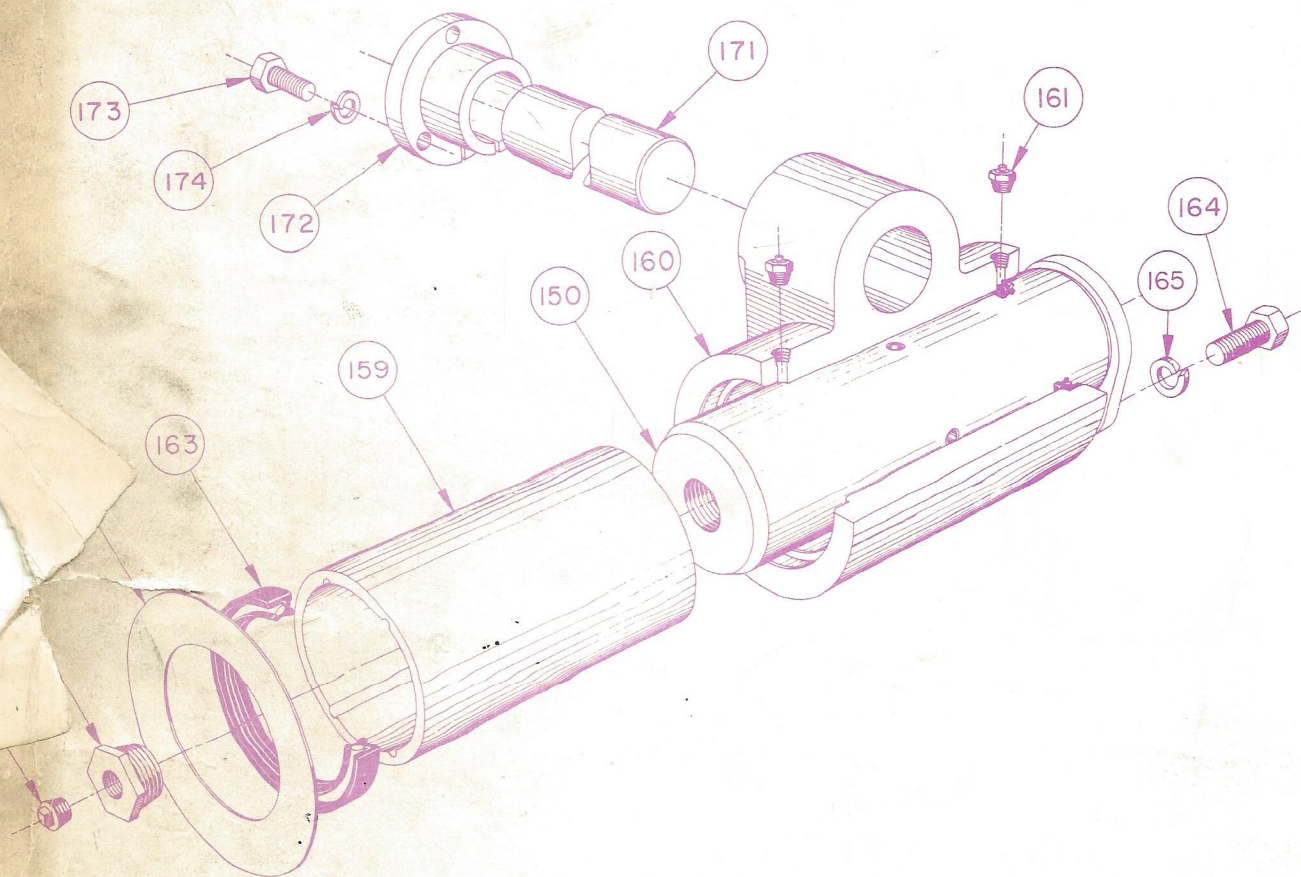

<u>Item No.</u>	<u>Part No.</u>	<u>Description</u>	<u>No. Req'd.</u>
		ASSEMBLY, EQUALIZER BEARING #E-110	1
150	BM 36122	Shaft, Equalizer Bearing	1
159	AM 36123	Bushing, Equalizer Bearing	1
160	CM 36121	Housing, Equalizer Bearing	1
161	AP 34160	Alemite Relief Fitting 1/8" #317400	2
163	920820	Oil Seal	2
171	BM 30042	Pin, Equalizer Bearing to Beam	1
172	AM 30041	Adjusting Bushing, Bearing to Beam	1
173	907416	Cap Screw, for Adj. Bushing	4
174	904114	Lockwasher, 3/4"	4
272	923802	Pipe Plug	1
272-A	925284	Pipe Bushing	1
366		Not used	