

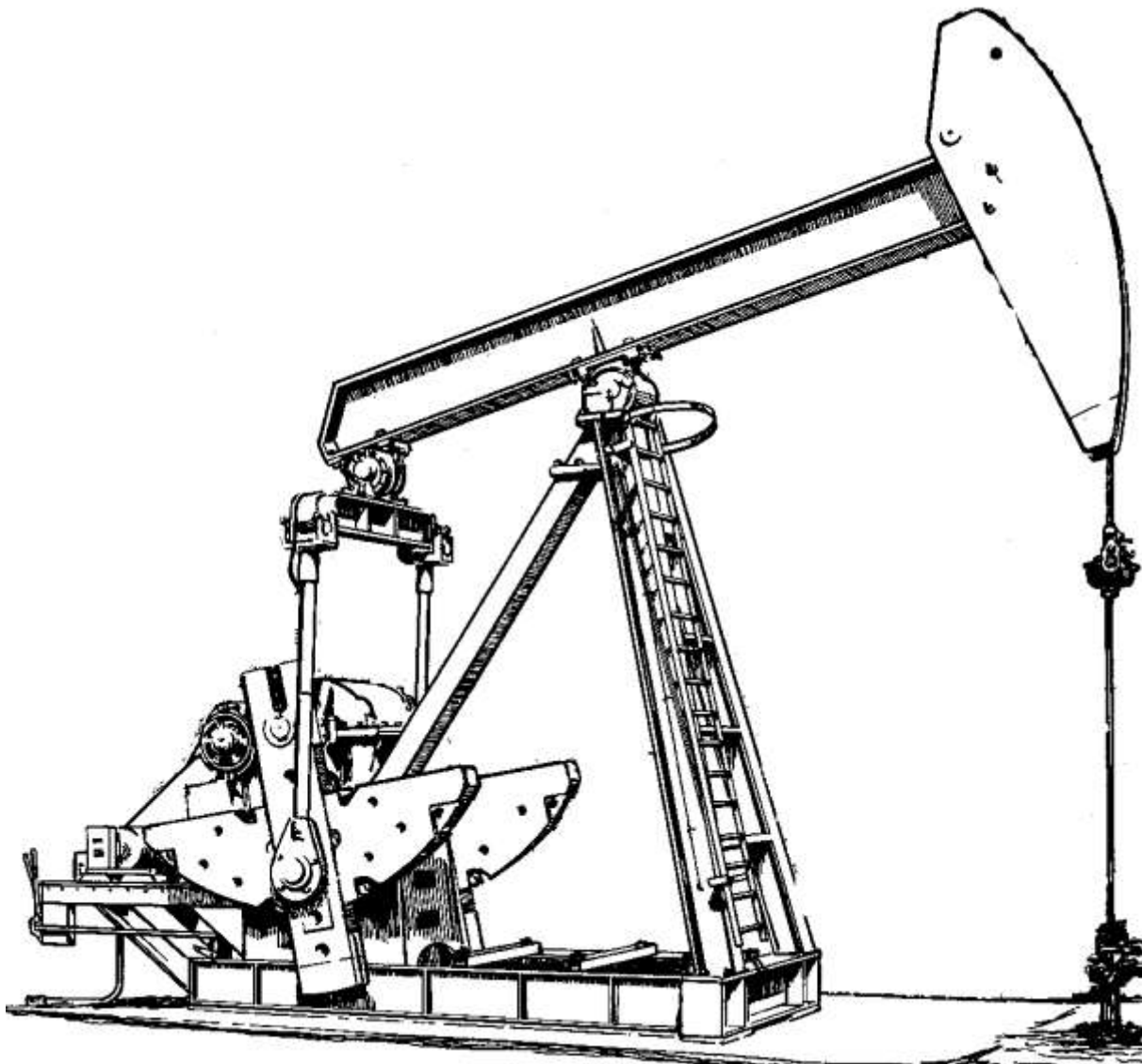

LS Petrochem Equipment Corporation

LS Pumping Unit

Field Assembly and Maintenance Instructions



C010400

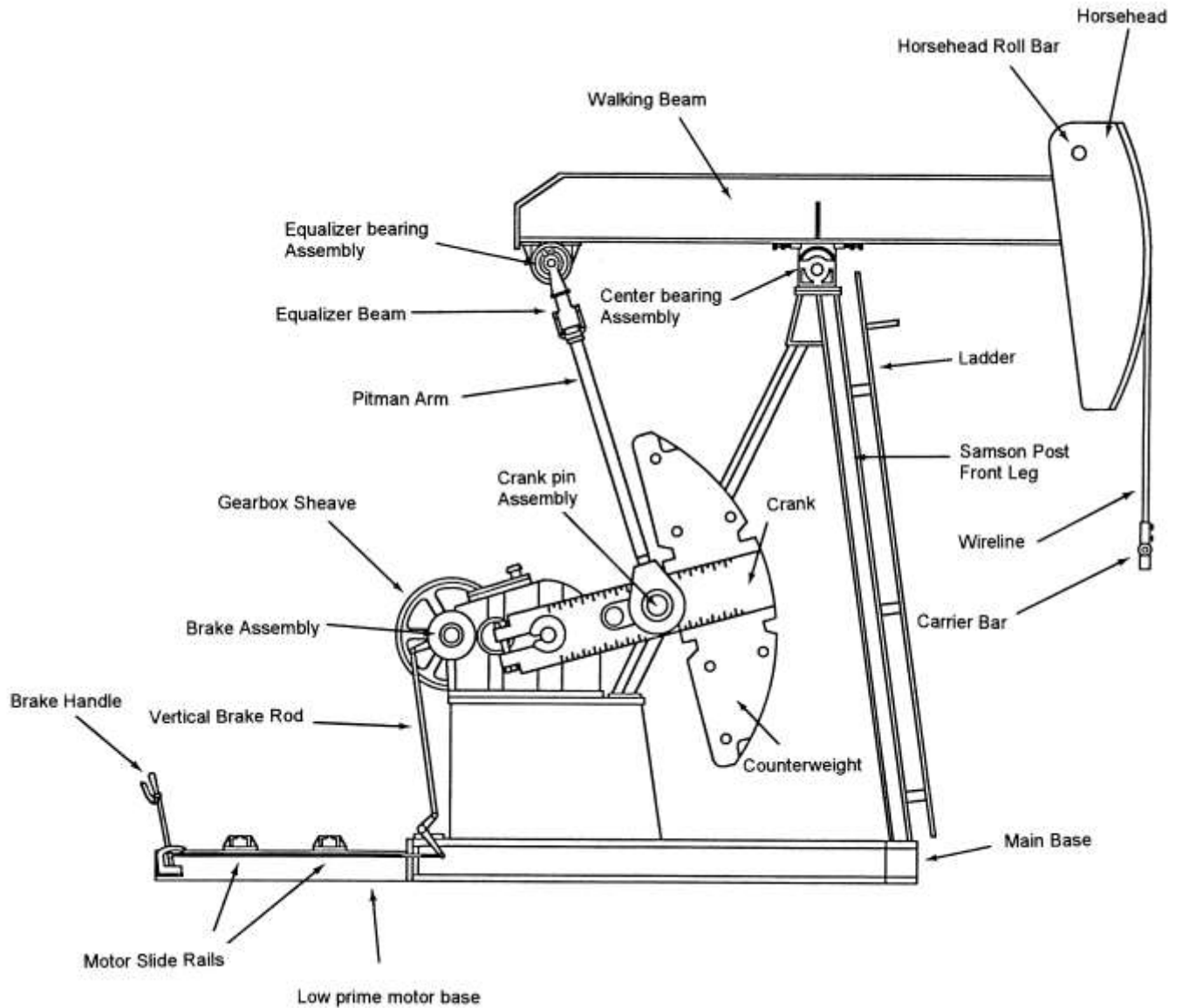

Table of Contents

Introduction	3
Safety	4-5
Safety Precautions	4
Safety Hazards	4
Safety Procedures	4-5
Securing the Brake Drum	4
Pumping Unit Guards	5
Crank Guards.....	5
Belt Guards	5
Prime Mover Guards	5
Proper Tooling and Clothing	5
Assembly Procedure	6-21
Foundation	6
Setting and Aligning the Base	6
Gear Reducer Installation and Alignment	8
Brake Release and Adjustment Procedure	9
Brake Linkage Assembly Procedure	10
Installation of Counterweights on Cranks	11
Samson Post Assembly	12
Installation of Samson Post to Base	12
Assembly and Installation of Ladder to Structure	13
Installation of Pitman Arms to Equalizer	14
Installation of Walking Beam to Equalizer	15
Installation and Alignment of Center Bearing to Walking Beam	16
Installation of Walking Beam Assembly to Structure	16
Installation of Wireline Assembly to Horsehead	17
Installation of Horsehead to Walking Beam	18
Installation of Prime Mover	19
V-Belt Installation and Alignment	19
Installation of Belt Guard	19
Crank Guard Installation	21
Carrier Bar/Polished Rod Connection	21
Lubrication	20-21
Reducer Lubrication	20
Crank Pin Bearing Lubrication	20
Equalizer Bearing Lubrication	20
Center Bearing Lubrication	21
Operating Procedure	22-25
Initial Start-Up	22
Counterbalance Adjustment	23
Changing Stroke Lengths	23-24
Crank Pin Installation	23
Returning the Unit to Operation	25
Maintenance Recommendations	25-28
Preventive Maintenance	25
Scheduled Maintenance	26-27
Monthly	26
Quarterly	26
Bi-Annually	26
Lubrication Specifications	27
Repair and Replacement Components	27
Supplement	28
Installation Tips	29



LS PUMPING UNIT TERMINOLOGY





INTRODUCTION

The LS Conventional Crank Balanced Pumping Unit is conventional in name only. It is a symmetrical rear mounted geometry Class I Lever System possessing crank counterbalance, and is designed for operation in bi-directional rotation of the cranks upon user requirements. All individual components of the unit and the unit as a whole represent the very best engineering design, manufacturing, quality control, and field operating experience that over 45 years of pumping unit manufacturing experience can bring to you. The specialized design of oil field pumping units and their application are LS's trademark. Within applicable load and torque ratings combined with adequate maintenance, your LS Pumping Unit will perform many years of dependable service.

The LS Pumping Unit has been designed to uncompromising standards and exceed API (American Petroleum Institute) standard requirements for beam pumping unit design.



SAFETY PRECAUTIONS

Before proceeding with the erection, operation, or maintenance of a pumping unit, it is essential that compliance of all applicable federal, state, and local safety laws be strictly observed.

All mechanical sucker rod pumping units have large and heavy rotating parts; therefore it is imperative that all personnel involved in the erection, operation, and maintenance of pumping units use extreme care when working near these heavy rotating parts. Failure to do so can cause severe bodily injury or death. Even a temporarily stationary pumping unit has components which may start moving from the effect of gravity. All personnel should stay clear of the cranks and counterweights or other elements which may start moving.

All electrical labor must be performed by a qualified electrician, especially on pumping units that utilize electric motors, automatic timers, or other related electrical devices. The electrical components should be regularly inspected and maintained in a safe operating condition by a qualified electrician,

SAFETY HAZARDS

LS strongly discourages the installation or maintenance of pumping units during thunderstorms or other types of inclement weather.

Times of particular peril from rotating or moving parts occur during unit erection, stroke change, counterbalance changes, and while obtaining dynamometer cards. When it is necessary to perform maintenance or work around the unit, be certain that the prime mover can not be started and that the cranks are blocked to prevent rotation.

Be aware of all power line positions prior to beginning installation or maintenance on or around the pumping unit. Your operation must be organized to avoid all contact with power lines. Failure to heed this warning could result in severe bodily injury or death to personnel.

SAFETY PROCEDURES

It is essential to prevent any rotation of the cranks for the purpose of service or maintenance of any kind. Never enter the crank sweep area for maintenance.

Securing The Brake Drum

Set the brake with cranks in desired position.

String a minimum 3/8" high tensile alloy chain through the hole in the brake drum nearest the brake trunnion and then around the trunnion itself, tighten the chain and attach the hook end around a link. Another common safety procedure is to place heavy timbers under the cranks. If the cranks are straight down, no rotative movement will start from them provided the carrier bar has not yet been attached to the polished rod or the well is clamped off. **Always stay clear of rotating cranks and counterweights and parts that may start moving, otherwise serious personal injury or death may occur.**





All chains and cable slings utilized in the erection of the pumping unit must be load certified and so designated by appropriate tags. The loads lifted may not be exceeded by that certification. A close visual inspection of all chains and cable slings should be performed prior to each use and reported monthly to responsible personnel in writing. Defective chains and cable slings may cause injury or death.

Pumping Unit Guards

Never operate your pumping unit without the appropriate guards in position. The purpose of guarding is to provide a safety barrier between the moving components of the pumping unit and the personnel that are familiar with the operation of the unit. When pumping units are operated within the domain of the general public it is imperative to place the pumping unit with guards in a totally enclosed area with locked access, thus preventing entry from unauthorized personnel. Failure to comply with this warning may result in severe injury or death to personnel. Various federal, state, and local agencies may require specific models of guarding, consequently the user is wholly responsible for the choosing of the precise guarding required. It is essential that all personnel comply with the respective federal, state, and local safety laws when operating their pumping units. Additional information on guarding your pumping unit may be found in API specification RP11ER.

Crank Guards

LS supplies crank guards in a variety of models. The 62 inch and 84 inch wire mesh guards would normally be sufficient to guard people familiar with the standard operation of pumping units, as well as various animals that would be at risk.

Belt Guards

Belt guards are furnished as standard equipment with each LS pumping unit unless specifically ordered without one. They are designed to protect the user from exposed sheaves and belts.

Prime Mover Guards

The exposed flywheels of prime movers should be guarded. LS makes this item available with the intent of preventing operating personnel from being accidentally injured by the flywheel.

Proper Tooling and Clothing

Always use the proper tools in the manner they were intended to be utilized for your job. When working in elevated areas, a safety belt or man basket is recommended to further reduce the possibility of accidents caused by falls.

The preferred clothing when working in or around pumping units is hard hat, safety glasses, safety shoes, and close fitting clothing without jewelry.



FOUNDATION

The foundation should be positioned in accordance with a foundation plan only. A copy of this plan is shipped with the unit. This foundation plan shows the hold down bolt location in relation to the well head, bolt and anchor nut sizes and number. No attempt is made on the foundation plan to prescribe the shape, depth nor characteristics of the foundation. The contractor must supply this information based on their knowledge of and experience with the soil conditions as they exist at the well site and assume full responsibility for the quality of the foundation. Foundation tie down bolts must be hammered tight after concrete has set up and pumping unit base alignment is complete.

SETTING AND ALIGNING THE BASE

Review the safety section of this manual prior to beginning erection of the pumping unit.

Step 1: Scribe, chalk, or mark a center line on the preferred foundation in relation to the center of the well head.

NOTE: A specially designed base for the two point Conventional pumping unit allows the unit an economical two-point installation. Foundation support is required only at the front and rear of the unit.

Both types of Conventional units may be installed on a one-piece foundation, provided the surface is level and the pumping unit is tied down as specified on the foundation drawing.



Step 2: Refer to the LS foundation plan furnished with the unit to determine the specific distance your pumping unit should set from the well head. Measure the distance from the wellhead and mark a line that intersects with the centerline.





Step 3: Lift the main pumping unit structure into position over the foundation.

CAUTION: Always stay clear of the base to avoid serious injury or death in the event that the load shifts or drops.



Unit Weight Table

Unit Size	Gear Reducer with Cranks	T-Base High Prime
1280	27,455 lbs.	13,950 lbs.
912	24,585 lbs.	10,617 lbs.
640	20,944 lbs.	9,343 lbs.
456	19,930 lbs.	8,227 lbs.
320	15,819 lbs.	6,267 lbs.
228	13,449 lbs.	5,469 lbs.
160	9,911 lbs.	3,290 lbs.
114	8,703 lbs.	3,382 lbs.

Step 4: Position the front edge of the base on the intersecting line made in Step 3. Be certain to align the center marks on the front and rear of the base with the centerline on the foundation.

Step 5: Measure the distance from the wellhead to each corner of the front cross member. The distance must be equal. If they are not equal, reposition the unit until the two distances are equivalent.

Step 6: Re-examine the distance from the center of the wellhead to the center line on the front cross member to insure it has remained unchanged.



Step 7: Place a level on the base beams to determine if the pumping unit is setting level. Level the unit as the foundation requires.



Step 8: Tighten the base tie down bolts, as required for your specific base arrangement. If utilizing anchor bolts or grout-, allow a sufficient period of time to attain full strength prior to tightening the foundation bolts.



GEAR REDUCER INSTALLATION AND ALIGNMENT

DANGER: The reducer with cranks is an assembly that comprises heavy rotating components. All personnel must exercise extreme caution when lifting this assembly to insure that the cranks are locked to prevent rotation.

Step 1: To install the reducer on its sub-base, attach slings or chains to the reducer and both cranks for proper stabilization. Never allow the slings or chains to bear against the slow speed shaft oil seals or damage will result. Mark the centerline on top of the sub-base and bottom of gear reducer and utilize this line for initial alignment. Place the reducer on the sub-base and install the bolting, leave the bolts loose for alignment shifting.



Step 2: The cranks should now be rotated to a safe position; the long end down. Remove the chains from the reducer but not the cranks. Disengage the brake lock-out and clear the crank sweep area. Slowly release the brake lever to allow the cranks to rotate to bottom dead center. The chains may now be removed from the cranks.

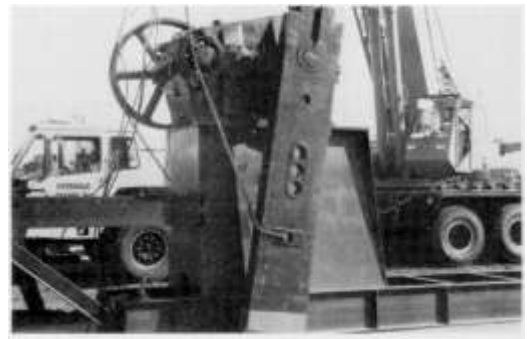



Step 3: Measure the distance from each end of the crank shaft to the alignment mark. Tighten all bolting on gear reducer and bolting on sub-base.



Step 4: Tighten all gear reducer bolts.

BRAKE RELEASE AND ADJUSTMENT PROCEDURE

Step 1: Release the brake by loosening the brake lockout nut.



Step 2: To adjust the brake pads, continue loosening the brake adjustment nut until the proper clearance is achieved between the brake lining and the brake hub.

Step 3: Tighten the nuts and adjustment bolts to maintain proper adjustment.



BRAKE LINKAGE ASSEMBLY PROCEDURE

Step 1: Connect one end of the vertical rod to the bell crank and secure it with the adjusting rod nut.



Step 2: Loosen the lock nuts and adjust the vertical brake rod length so that the bell crank is horizontal when the brake pads contact the hub.



Step 3: Connect the upper end of the vertical rod to the cam.

Step 4: Connect one end of the horizontal brake rod to the yoke at the brake handle assembly.



Step 5: Adjust the length of the horizontal rod between the bell crank and the brake handle so that the cam is horizontal when the brake handle is in the forward position.



Step 6: Connect the other end of the horizontal rod to the bell crank.

Step 7: Tighten all yoke nuts to maintain adjustments.

INSTALLATION OF COUNTERWEIGHTS ON CRANKS

Step 1: Set the brake.

Step 2: Insert a chain or cable through the holes in the counterweight.

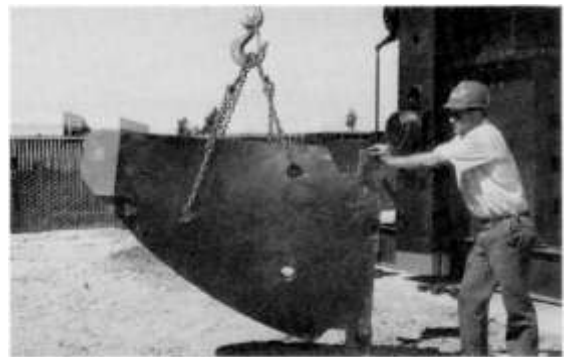

Step 3: Install the "T" bolts in the slot of the crank.





Step 4: Set the counterweight on the bolts.



Step 5: Install a flat washer, a standard nut, and jam nut on each of the counterweight bolts and tighten securely.

Step 6: Repeat the installation procedure for each of the counterweights to be installed,

SAMSON POST ASSEMBLY

Step 1: Assemble the support leg to the samson post, using the bolts provided. Do not tighten the bolts securely at this time.



INSTALLATION OF SAMSON POST TO BASE

Step 1: Thread the lifting chain, or cable, between the support beams and around the top bracket. Lift and position the samson post on the base.





Step 2: Use a bolt or wrench to align the holes of the samson post with the base.



Step 3: Insert and tighten all bolts that secure the samson post assembly to the unit base.

Step 4: Tighten all bolts at the top of the rear support beam using an alternating sequence from one side of the unit to the other. This will avoid inducing uneven stresses in the flanges.

ASSEMBLY AND INSTALLATION OF LADDER TO STRUCTURE

Step 1: Assemble the brackets to the ladder, leaving the bolts only hand tightened. On units with three supports, the longer bracket will be used at the top of the ladder, the shorter one is for use at the middle of the ladder.

CAUTION: All bolts should be installed so that the bolt heads are on the inside of the ladder.

Step 2: Position the ladder safety ring on the outside of the ladder rails at the top of the ladder and bolt securely.





Step 3: Position the ladder against the samson post and securely tighten all bolts.



INSTALLATION OF PITMAN ARMS TO EQUALIZER

Step 1: Position the equalizer on the ground so that the equalizer bearing housing bolt holes are on top of the beam.



Step 2: Select the pitman arm which has the lubrication line attached to it. Note the position of the lubrication line on the equalizer. The two should be assembled so that the lubrication lines are on the same side.

Step 3: Equalizer holes should be cleaned thoroughly prior to inserting upper pitman pins in housings. Pitman pins should be covered with a rust preventative coating.





Step 4: Mount the pitman to the equalizer beam and insert the upper pitman pin in the housing holes. Install the bolts and tighten.



Step 5: Connect the lubrication line from the pitman arm to the equalizer, and from the equalizer bearing, using the flexible hoses provided in the parts box.



Step 6: Attach and assemble the other pitman member according to the same procedure.

INSTALLATION OF WALKING BEAM TO EQUALIZER

Step 1: Loosen the bolts on the two equalizer flanges and install on the equalizer bearing assembly pin (already attached to walking beam).



Step 2: Position the flanges on the equalizer assembly to align with those on the equalizer beam.

Step 3: Install bolting and nuts and tighten with hammer



wrenches.

INSTALLATION AND ALIGNMENT OF CENTER BEARING TO WALKING BEAM

Step 1: Position center bearing on the ground with larger mounting flange facing upwards.

Step 2: Lift the walking beam and position the center of the beam on the center bearing. Insert the bolts and loosely tighten.



Step 3: To align the center bearing measure the distance from the front of the walking beam to the center of the center bearing shaft. When measurements on both sides are equal, tighten the bolts securely.

INSTALLATION OF WALKING BEAM ASSEMBLY TO STRUCTURE

Step 1: Attach lifting lines near each end of the walking beam assembly to ensure a level lift.



Step 2: Position the center bearing housing on top of the samson post. Insert the bolts and hand tighten.



Step 3: Attach the pitman arms to the crank pin assemblies and securely tighten all bolts.



Step 4: Attach a section of flexible hose from the parts box and attach one end to the center bearing and to the samson post.



INSTALLATION OF WIRELINE ASSEMBLY TO HORSEHEAD

Step 1: Place the wireline assembly in position on the horsehead.



Step 2: Position the carrier bar so that it is relatively straight with the open end facing the polish rod.



Step 3: Install the bolts in horsehead to secure the wireline assembly.



Step 4: Install the horsehead adjusting bolts.



INSTALLATION OF HORSEHEAD TO WALKING BEAM

Step 1: Lift the horsehead into position and place the roll bar behind the flange on the walking beam.

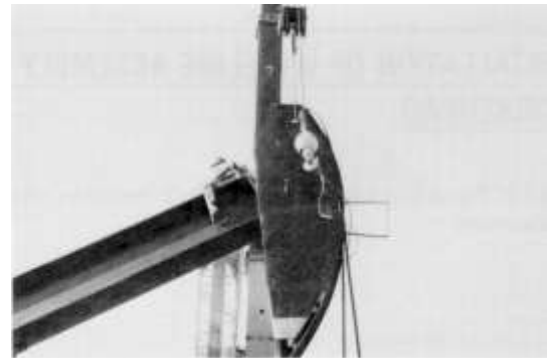

Step 2: Install the safety flag through the horsehead and angle slot on the walking beam and tighten adjusting bolts.



INSTALLATION OF PRIME MOVER

Position the slide rails on the slots near the end which is toward the reducer so that the belts can more easily be installed after positioning the prime mover. Face the slide rail to match the mounting holes on the prime mover. Similarly install and space the bolts in the slots on the slide rails. Carefully lower the prime mover onto the slide rails. Install the nuts without tightening until the belt alignment is complete,

V-BELT INSTALLATION AND ALIGNMENT

Install a matched set of belts, always using the inside grooves if either sheave has an excess number of grooves. Utilize a string to align the inside faces of the sheaves (see photo). Shift the prime mover as required and then tighten the bolts that attach the prime mover to the slide rails. Tighten the belts by using the adjustment screws. All new belting should be rechecked for tightness after 24 hours.



INSTALLATION OF BELT GUARD

Step 1: Raise the belt guard and position it over the sheaves.



Step 2: Insert the bolt in the slotted bracket at the gear reducer.





Step 3: Position the upright support and install the bolt.

Step 4: Adjust the clearance between the belt guard and sheaves by raising the belt guard and tightening the bolts in the slotted brackets.

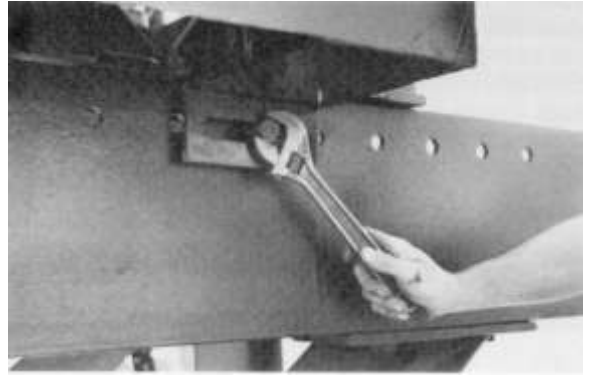

Step 5: Make certain that there is adequate clearance between the belt guard and the rotating cranks and then securely tighten bolting.

REDUCER LUBRICATION

Remove the inspection cover from the gear reducer housing and fill with oil until the oil level is even with the top drain plug (see photo). Replace the cover, insuring that the gasket is not damaged to prevent contamination of the oil. For specific lubrication data and the amount required, see page 27 of this manual.



CRANK PIN BEARING LUBRICATION

Bearing assemblies are lubricated at the factory, however it is recommended that all bearing assemblies be rechecked for proper grease prior to starting unit. Using an approved grease, pump the grease into the bearing assembly until it overflows through the relief fitting located in the bearing coverplate. Always pump grease in slowly to avoid damage to the oil seals.

EQUALIZER BEARING LUBRICATION

Bearing assemblies are lubricated at the factory, however it is recommended that all bearing assemblies be rechecked for proper grease prior to starting unit. Using an approved grease, pump the grease into the bearing assembly until it overflows through the relief fitting located in the bearing coverplate. The grease fitting for the equalizer bearing is located on one of the pitman arms. Always pump grease in slowly to avoid damage to the oil seals.



CENTER BEARING LUBRICATION

Bearing assemblies are lubricated at the factory, however it is recommended that all bearing assemblies be rechecked for proper grease prior to starting unit. Using an approved grease, pump the grease into the bearing assembly until it overflows through the relief fitting located in the bearing housing. The grease fittings for the center bearing are located on the samson post legs. Always pump grease in slowly to avoid damage to the oil seals.

CRANK GUARD INSTALLATION

If crank guards are purchased from LS a crank guard installation schematic, which shows the panel part numbers and their location relative to each other and to the well head, is shipped with the unit. The front panel is located beneath the samson post and heel-clamps to the base beam flanges where possible. The side panel is attached to the front and rear panels with hinges consisting of stationary hooks on the side panels and vertical pipe receptacles on the front and rear panels.

CARRIER BAR / POLISHED ROD CONNECTION

Position the unit in the same stroke position as the bottom-hole pump. Remove the gate from the carrier bar and position the slot in the carrier bar around the polished rod. Replace the gate and secure the gate latch in the notch provided. Install the rod clamp at the carrier bar and tighten the bolts according to the clamp manufacturer's torque recommendations. Remove the rod clamp at the well stuffing box.



INITIAL START UP

- 1) Check the oil in the reducer.
- 2) Check the lubrication of all bearing assemblies.
- 3) Clear the crank swing area. Remove all tools or other obstructions left on the unit and foundation.
- 4) Make sure all guarding is in place.
- 5) Disengage the positive-stop brake lock out.

Direction of Rotation

The LS conventional pumping unit can operate with the rotation in either direction. However, the preferred direction is counter-clockwise with the well head to the right.

Initial Crank Rotation

The initial crank revolution should be as slow as possible. Check for the proper clearance between the cranks and the belt cover, crank guards, and pitman side members. The bottom hole pump spacing should also be checked during the first revolution.

COUNTERBALANCE ADJUSTMENT

Determining the Required Counterbalance

Efficient operation, torque loading, and maximum life of a pumping unit are all dependent on the proper counterbalance. Counterbalance requirements can be determined very accurately or estimated by various methods.

- 1) Polished rod dynamometer:
A dynamometer card analysis is the most accurate method for determining loading and counterbalance. This involves using a dynamometer to record the well load through a stroke cycle and then using torque factors to determine the reducer torque and counterbalance required for balanced conditions.
- 2) Ammeter
A clip on ammeter may be used to compare the upstroke and downstroke current on electrically powered units. When the counterbalance is adjusted so that the current peaks are equal, the unit will be roughly in balance.
- 3) Vacuum Gauge:
A vacuum gauge may be used to compare torque peaks on engine driven units much like the ammeter is used on electrically driven units. Vacuum pressure decreases as engine output increases.
- 4) Sound of the Prime Mover:
An approximate estimation of balance can be made by listening to the characteristic sound of the prime mover as it drives the unit. Some speed change will occur as the peak loads are approached-, speed changes will cause the sound of the prime mover to vary.
- 5) Belt Tension:
Belt tension and subsequent belt stretch increases with load. This causes an proportional amount of slack in the belts on the side opposite the direction of rotation of the prime mover. A visual inspection of the belt sag on upstroke or downstroke, can be used to estimate counterbalance.

Counterweight Adjustment

Rotate the unit and apply the brake so that the crank is slightly downhill in the direction that the weights are to be moved. Set the brake, engage the brake lockout bolt or pawl, and secure the cranks against rotation. Loosen the counterweight bolts just enough to allow the weights to be moved. Use the pinion adjusting wrench to move the weights to the desired position. It is important to note that larger weights may have to be moved with the aid of a crane or a pry bar. The weight on the crank may be moved in a similar manner. After positioning the weights in the desired location, tighten the counterweight bolts utilizing recommended levels of tightness, and add a second nut for a jam nut.



CHANGING STROKE LENGTHS

Locate the cranks at approximately the 2 o'clock position and set the brake. Place a polished-rod clamp at the stuffing box and tighten according to the clamp manufacturer's recommendations. Using the prime mover or a crane-lift, relocate the cranks to the 12 o'clock position and set the brake.

You may now disconnect the carrier bar from the polished rod.

Insert a long chain through the carrier bar and install the gate back into the carrier bar. Hold the end of the chain and pull the carrier bar away from the polished rod while slowly releasing the brake and letting the cranks down to the 4 o'clock position.

Always disconnect or lockout the prime mover. Remove the crank guard side panel to gain access to crank area, secure the unit against rotation by the brake lock out bolt or pawl.

Place one 1-1/2 ton come-a-long between the carrier bar and the front cross-member of the base. Place another between the equalizer and the holes on the front of the sub-base. Tighten both come-a-longs to restrain possible movement or tilting of the walking beam that will occur once the crank pins are removed from the cranks.

Crank Pin Removal

Remove the cotter pin and then remove the crank pin nut using the box end hammer wrench (furnished as an option), and a minimum 14 pound sledge hammer with a full length handle.

Drive out the crank pin using a drive nut and tools above. The drive nut (furnished as an option) is screwed on until it bottoms on the end of the pin. Hammer against the head of the drive nut until the pin is loose. If a drive nut is not available, it is recommended that the hammer hit as squarely on the end of the pin as possible to prevent surface damage. Once the pin becomes loose, do not remove it from the hole. Remove the drive nut and install the original nut three or four threads deep. This procedure should also be used on the opposite crank pin.

Check the crank pin clearance in the hole and adjust come-a-longs accordingly so that when the pins are removed they will not fall nor pull up in a sudden motion. Remove the nuts and pull the crank pins out of the crank holes. The pitman side members will support the crank pin bearing assemblies until the pin is installed into another hole. It is recommended that rust preventive be applied to the crank pin bore after the pin is removed.

Crank Pin Installation

Step 1: Use a safe solvent to clean the crank pin, crank pin hole, and the surface of the crank that the nut will seat against. Remove all paint, burrs, and other foreign matter from these areas. Always inspect the crank pin and hole surfaces for rust or wear, as these conditions may indicate that the crank pin was loose. Use a spot bluing to check the contact between the pins and the new holes. If the contact is less than 90% of the length of the fit, consult the nearest LS service center or sales representative.





Step 2: Adjust come-a-longs to line up the crank pins with the proper holes for the stroke length desired. Apply a light coat of oil on the tapered pin, threads, and crank pin hole. All excess oil should be wiped off with a clean cloth prior to inserting the crank pin high alloy bushing into the crank hole.



Step 3: Install the crank pin bearing assembly.



Step 4: Using the box end hammer wrench, tighten the crank pin nut as tight as possible by hand. This will establish the metal to metal position for the final tightening procedure.

Step 5: Using a sledge hammer on the wrench, turn the nut two cotter pin notches past the hole in the pin and line up the hole in the pin with the third cotter pin notch.

Install the cotter pin. *Never* back the nut off to insert the cotter pin. If you have turned the nut too far, remove the crank pin and repeat all of the installation procedures.





Returning the Unit to Operation

With the brake engaged, remove the come-a-longs, unchain the drum and disengage the lock out bolt or pawl. Reinstall the crank guard panels.

Hold the carrier bar away from the polished rod with the chain and slowly release the brake to let the cranks go to the bottom. Engage the prime mover (or crane) to slowly reposition the cranks at 12 o'clock while holding the carrier bar away from the polished rod. Remove the chain from the carrier bar and attach the carrier bar to the polished rod-, please note that the bottom hole pump spacing will need to be checked and the polished rod clamp may have to be repositioned to accommodate the new stroke length.

Slowly release the brake to transfer the well load back to the carrier bar. Make certain that the load is not on the polished rod clamp at the stuffing box. If necessary, use the prime mover to lift the load. Remove the polished rod clamp at the stuffing box that was used to clamp off the well load.

It is important to note that after a stroke length change, the counterbalance should be checked and the weights repositioned for the proper balance.

PREVENTIVE MAINTENANCE

Preventive maintenance is essential to promote safety, prolong unit life, and to prevent expensive failures. Many items can be checked by visual inspection and by listening for unusual noises. It is recommended that the unit should be checked upon each visit to the location.

The following visual inspections are recommended before approaching the pumping unit:

- 1) Visually inspect both crank pins for tightness.
- 2) If using a slow speed engine, visually inspect the flywheel for loose bolting.
- 3) Visually inspect the counterweights for tightness to the crank.
- 4) Visually inspect the center bearing to insure it has not worked loose.
- 5) Visually inspect the vertical alignment of the unit with the well.
- 6) Visually inspect the distance between the pitman-side members and the cranks on each side of the unit.
- 7) Visually inspect the wireline to insure it is properly tracking on the horsehead. Also look for broken strands of wire fraying from the wireline,
- 8) Visually inspect the level of the foundation for an uneven position causing alignment shifts.
- 9) Visually inspect the unit for loose or missing bolting. Loose bolts will eventually fail in fatigue and are responsible for the majority of pumping unit failures.

If any of the above conditions exist, the unit must be shut down immediately and the problem corrected.



SCHEDULED MAINTENANCE

There are several items that should be checked on a regular interval to assist in extending the life of your pumping unit.

Monthly

Gear Reducer

The reducer oil level should be checked. Loss of oil from the reducer is usually caused by seal leakage at the shafts or leakage at the parting line of the housing. If the oil level is low, remove the inspection cover and add oil to the proper level.

Structural Bearings

Visually inspect the structural bearings for oil seal leaks. This would include the crank pin, equalizer, and center bearing assemblies. Grease fittings are located at ground level, and if needed, the grease should be pumped in slowly to avoid pushing out the oil seals.

Quarterly

Belts & Sheaves

Belt alignment and tension should be checked and adjusted to prolong belt life. Under normal utilization belts will stretch and wear. It is recommended that new belts be retightened after the first 24 hours of operation. Also check the sheaves for wear, chips, or cracks.

Brake & Drum

The brake lining should be inspected for wear and clearance adjustment. When the brake control lever is fully engaged, there should be several notches left on the ratchet.

Inspect the brake drum for cracks around the hub and key area. Also look at the brake lock out bolt or pawl for damage.

Bi-Annually

Gear Reducer

It is recommended that an oil sample be taken every six months to determine condition of the oil. Collect a typical sample (one cup) of the reducer oil in a transparent receptacle. A visual inspection will expose possible dirt, sludge, water emulsion, or other forms of contamination. You may also desire to keep a sample of new oil for comparisons. If you determine that you have any of the following conditions in the lubricant, check with a qualified vendor regarding replacement:

- 1) An acid or singed odor indicates oxidation of the oil to the degree that it should be replaced.
- 2) If sludge is observed in the used sample, the oil should be replaced or filtered to remove the sludge. This condition is prevalent if the lubricant has not been changed for a long period of time.
- 3) If water exists in the used sample, the water should be completely drained from the reducer. Water presence in oil can be detected by placing a drop or two on a heated metal surface. Subsequent bubbling will occur with as little as 0.1 % of water present in the oil. If there is greater than 0.2% water by volume, an oil change is recommended.

Wireline

Visually inspect the wireline for wire fraying. A rusty wireline should be cleaned and coated with a wireline lubricant as specified on page

Bolting

Check all bolts. Retighten as recommended in the Supplement. Loose bolting will eventually fail.



LUBRICATION SPECIFICATIONS

Gear Reducer

For temperatures down to 0° F use an AGMA #5 EP (ISO VG220) premium mild, extreme-pressure lubricant (preferably a sulphur-phosphorus type) with rust and oxidation inhibitors and an anti-foam agent. The pour point of the oil should be 5° F or lower. For temperatures down to -30° F use an AGMA #4 EP (ISO VG150) premium mild, extreme-pressure lubricant (preferably sulphur-phosphorus type) with rust and oxidation inhibitors and an anti-foam agent. The pour point of the oil should be - 15° F or less.

Reducer Oil Capacity

Model	Capacity	Model	Capacity
1280D	243 Gal.	320D	75 Gal.
912D	180 Gal.	228D	43 Gal.
640D	106 Gal.	160D	37 Gal.
456D	88 Gal.	114D	25 Gal.

Structural Bearings

Never use soda-soap grease. For temperatures down to 0° F use a NLGI No. 1 lithium, soap-base grease with lead-naphthanate, extreme-pressure additive. The oil in the grease should have a viscosity of approximately 1000 SSU at 100° F. For temperatures down to -30° F, use a premium NLGI No. 0 lithium, soap-base grease with lead-naphthanate, extreme-pressure additive.

Wireline

Always clean the wireline by wire brushing. Do not use solvent. Apply a reliable wire rope lubricant that will penetrate and adhere to the rope.

REPAIR AND REPLACEMENT COMPONENTS

For the proper repair or modification of an LS pumping unit, use only parts that meet LS specifications. Failure to do so may result in possible injuries to personnel and equipment failure.

A complete line of replacement components is available from LS or an LS representative. When parts are required, furnish the complete unit designation, serial number, and shipping order number for the unit in which the part is to be used.



SUPPLEMENT

Fasteners

Bolting is a vital part of your pumping unit. The surfaces under the bolt head and nut and the contacting surfaces must be flat, clean, and free of burrs so that the bolted members join in a "metal to metal" contact. Bolts which are properly tightened during erection, and retightened about a week later, will retain their grip under normal operating conditions. Improperly tightened bolts will break in fatigue and may cause serious failures and injury to personnel. The following table gives recommended tightening torques.

Proper Tightening Torques for Nuts and Cap Screws with Metal to Metal Grip		
$\frac{3}{8}$ " -	16 NC	15 to 24 ft lbs.
$\frac{1}{2}$ " -	13 NC	32 to 44 ft lbs.
$\frac{5}{8}$ " -	11 NC	59 to 74 ft lbs.
$\frac{3}{4}$ " -	10 NC	99 to 116 ft lbs.
$\frac{7}{8}$ " -	9 NC	153 to 175 ft lbs.
1 " -	8 NC	225 to 256 ft lbs.
1 $\frac{1}{8}$ " -	7 NC	320 to 360 ft lbs.
1 $\frac{1}{4}$ " -	7 NC	452 to 510 ft lbs.
1 $\frac{1}{2}$ " -	6 NC	780 to 880 ft lbs.

Elastic Grip

The grip is not always metal to metal. In applications such as foundation bolts, heel-clamp bolting, and bolts used on various brackets, the fasteners will be subjected to cyclic loading. The tightening torques on these applications will vary, but should be approximately one half of the values shown above. It is important to note that bolting should always be over tightened rather than under tightened.



INSTALLATION TIPS

Samson Post

- When erecting the samson post assembly, it is best to use "spud bars" to assist in lining up all the bolt holes in the three leg flanges. If samson post leg flange holes do not line up exactly with the main base frame bolt holes, it is recommended to loosen the upper samson post rear leg bolts, re-align the flange holes, then re-tighten the upper samson post rear leg bolts. This recommendation is lieu of using a pry bar to force the rear leg to fit the main base pedestal bolt holes. Forcing any structural member into place creates structural stress.
- Insure that unit is level about its foundation, side to side, and front to back.

Gearbox

- Check that gearbox is filled with gear oil. Oil should be filled to the top oil-level hole in the gearbox.
- Do not lift the gearbox with top lifting hooks cast into top lid section. These lifting hooks are intended to pick up ONLY the lid itself, not the entire gearbox.

Brake

- Brake must be adjusted very carefully to insure that the brake shoes do not wear against brake drum.
- For brake swivel installation on high-prime motor-mount units, the short lever arm faces the unit outside and connects to the horizontal brake pull rod, which connects to the brake handle assembly. The long lever arm faces the unit inside and connects to the vertical brake pull rod, which connects to the brake shoe assembly.

Center Bearing

- Center bearing is to be positioned on walking beam such that the lubrication port on the center bearing shaft is pointed to the "brake-hub" side of the pumping unit when the walking beam is installed atop the samson post.
- The middle center-bearing-trunion to samson-post bolts must be installed with the bolt heads up and the nuts down, to allow for clearance of the center bearing housing during operation.
- Insure that the adjusting bolt on the center bearing shaft is tight and that the locking washer tab is bent down in slot to hold the nut secure in place.

Equalizer

- Equalizer pin clamps are to be positioned on the equalizer beam such that the side of the clamp with the greater angle is positioned to the outside, away from the equalizer bearing housing.
- Equalizer beam is to be assembled on the equalizer pin clamps so the lubrication line is on the same side as the lubrication port on the equalizer bearing shaft.

Pitman arm & crank pin

- The Pitman arm with the lubrication line is to be assembled on the end of the equalizer beam with the lubrication hose clamps.
- The upper Pitman arm bolts should be installed with the nuts pointed away from the unit. If the nuts are on the inside, the Pitman arms will not properly pass-by the equalizer beam when they are spread.
- The Pitman arm "banjo" section that fits around the crank pin assembly has a tapered bore. Insure that pitman arms are installed with the larger diameter bore on the inside, toward the unit.
- Crank pin sleeve shoulder must be set against the outside face of crank before crank pin is pushed in.



11E-0018

INSTALLATION TIPS

Samson Post

- When erecting the samson post assembly, it is best to use "spud bars" to assist in lining up all the bolt holes in the three leg flanges. If samson post leg flange holes do not line up exactly with the main base frame bolt holes, it is recommended to loosen the upper samson post rear leg bolts, re-align the flange holes, then re-tighten the upper samson post rear leg bolts. This recommendation is lieu of using a pry bar to force the rear leg to fit the main base pedestal bolt holes. Forcing any structural member into place creates structural stress.
- Insure that unit is level about its foundation, side to side, and front to back.

Gearbox

- Check that gearbox is filled with gear oil. Oil should be filled to the top oil-level hole in the gearbox.
- Do not lift the gearbox with top lifting hooks cast into top lid section. These lifting hooks are intended to pick up ONLY the lid itself, not the entire gearbox.

Brake

- Brake must be adjusted very carefully to insure that the brake shoes do not wear against brake drum.
- For brake swivel installation on high-prime motor-mount units, the short lever arm faces the unit outside and connects to the horizontal brake pull rod, which connects to the brake handle assembly. The long lever arm faces the unit inside and connects to the vertical brake pull rod, which connects to the brake shoe assembly.

Center Bearing

- Center bearing is to be positioned on walking beam such that the lubrication port on the center bearing shaft is pointed to the "brake-hub" side of the pumping unit when the walking beam is installed atop the samson post.
- The middle center-bearing-trunion to samson-post bolts must be installed with the bolt heads up and the nuts down, to allow for clearance of the center bearing housing during operation.
- Insure that the adjusting bolt on the center bearing shaft is tight and that the locking washer tab is bent down in slot to hold the nut secure in place.

Equalizer

- Equalizer pin clamps are to be positioned on the equalizer beam such that the side of the clamp with the greater angle is positioned to the outside, away from the equalizer bearing housing.
- Equalizer beam is to be assembled on the equalizer pin clamps so the lubrication line is on the same side as the lubrication port on the equalizer bearing shaft.

Pitman arm & crank pin

- The Pitman arm with the lubrication line is to be assembled on the end of the equalizer beam with the lubrication hose clamps.
- The upper Pitman arm bolts should be installed with the nuts pointed away from the unit. If the nuts are on the inside, the Pitman arms will not properly pass-by the equalizer beam when they are spread.
- The Pitman arm "banjo" section that fits around the crank pin assembly has a tapered bore. Insure that pitman arms are installed with the larger diameter bore on the inside, toward the unit.
- Crank pin sleeve shoulder must be set against the outside face of crank before crank pin is pushed in.