

LS Pumping Units

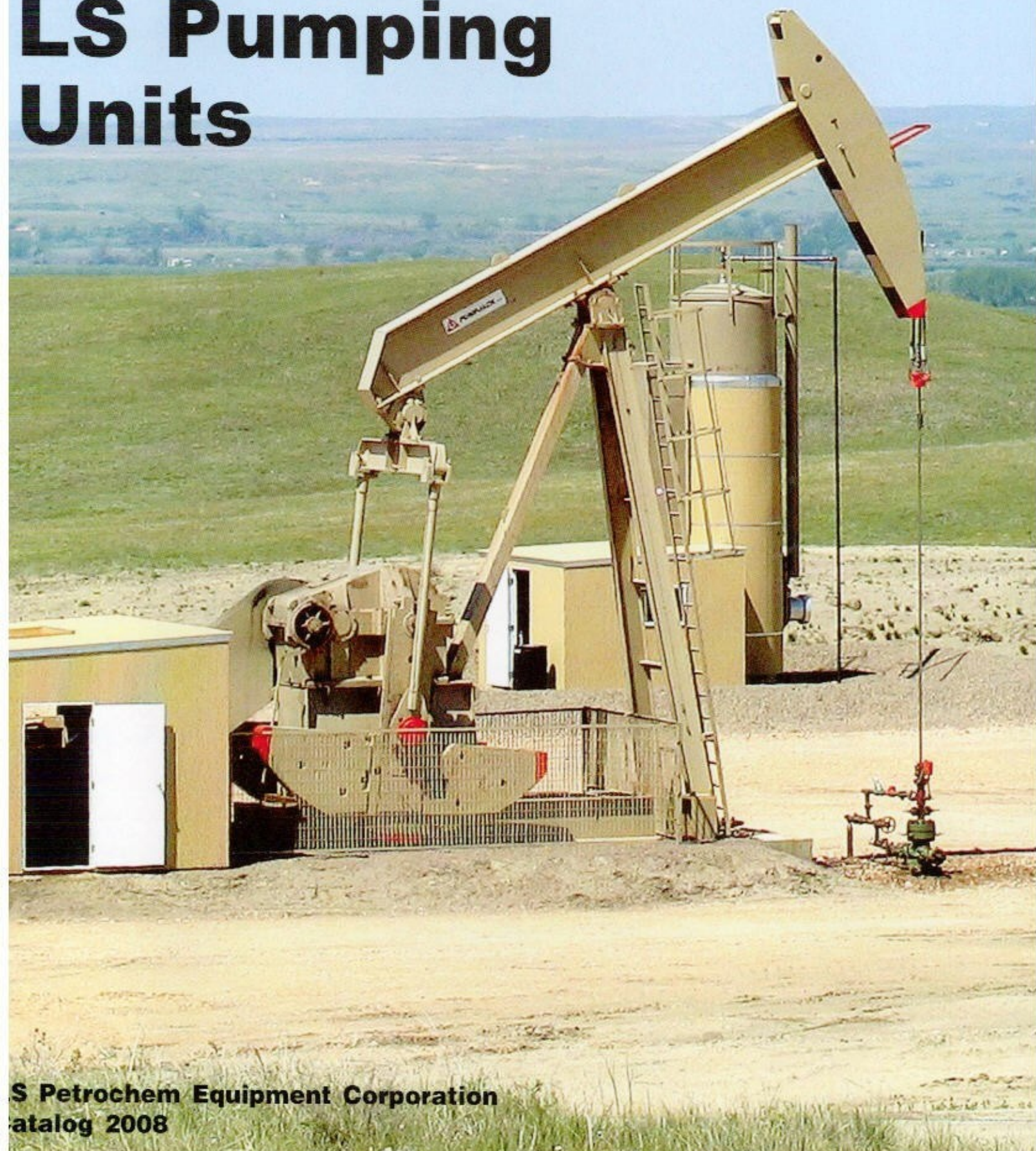

LS PUMPJACK.com

LS PUMPJACK's pumping units are superbly engineered, quality constructed products.

Our complete line of unit models is manufactured to API standards in sizes ranging from 40 to 1280, enabling operators to satisfy the most challenging of lifting requirements.

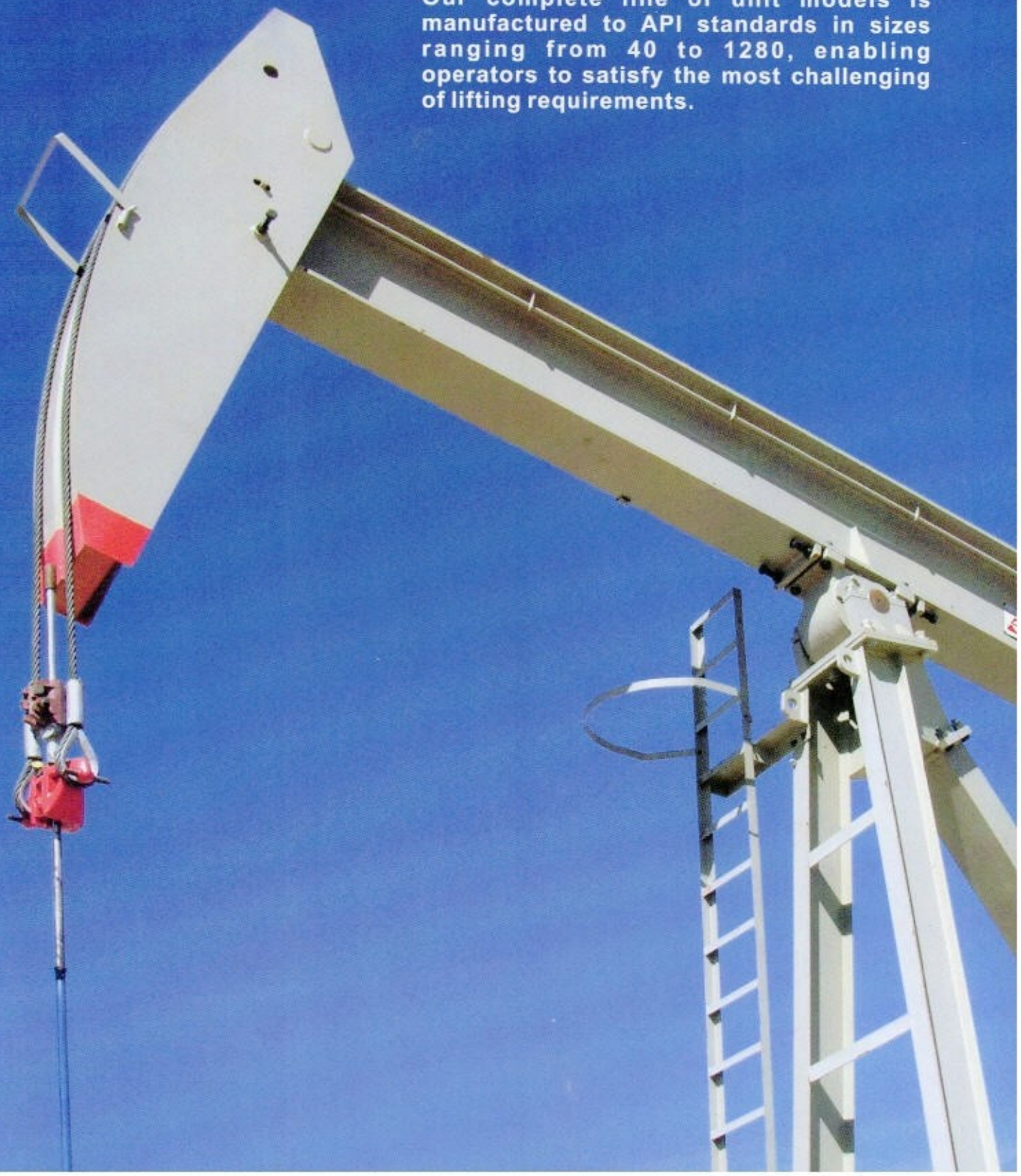

TABLE OF CONTENT

LS Components

Page 5

Conventional Pumping Units

Page 9

Enhanced Geometry Pumping Units

Page 17

Worldwide Sales and Service

Page 23



Ours.

Theirs.



Crank Pin Bearing Assemblies

Both of the crank pins and bearings pictured above are from API model size 456 conventional pumping units. The one on the left is from LS PUMPJACK; the one on the right is standard size for many other manufacturers.

LS PUMPJACK's crank pin assemblies are designed with double-row, self-aligning bearings which, due to their size, insure the longest wear life expectancy in the industry. Special features, such as our high alloy steel sleeves in the crank hole, all but eliminate damage and downtime.

LS Components

Center Bearing Assembly

LS PUMPJACK's center bearing assembly utilizes heavy duty, self aligning, anti-friction bearings. The metal-to-metal seal is designed to eliminate damage resulting from over lubrication. All bearings and oil seals are readily available through standard suppliers.



Equalizer Bearing Assembly

Our massive, double row, self aligning spherical bearing is encased in a rugged cast steel bearing housing to provide constant equalization of loads to the pitmans and crank pins. Ground level lubrication systems are standard.

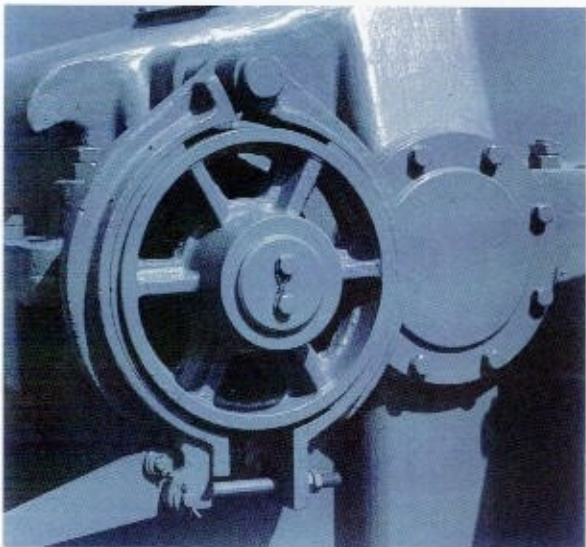
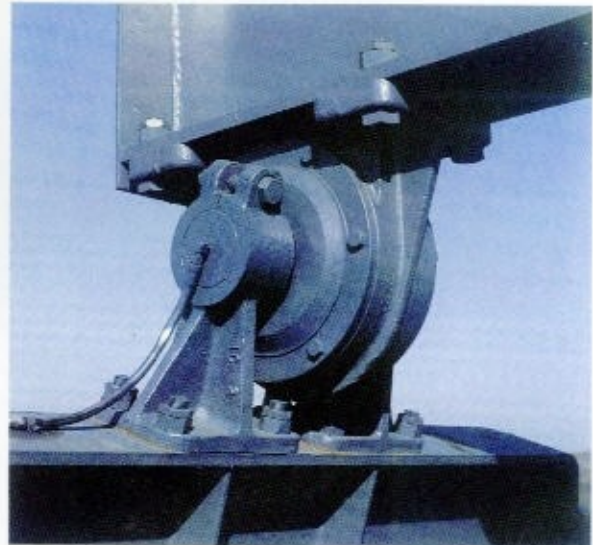

Brake Assembly

LS PUMPJACK's anti-skid brake system provides stopping when engaged. Our cast steel, external brake design with safety lockout ensures operators of immediate and decisive brake response when needed.

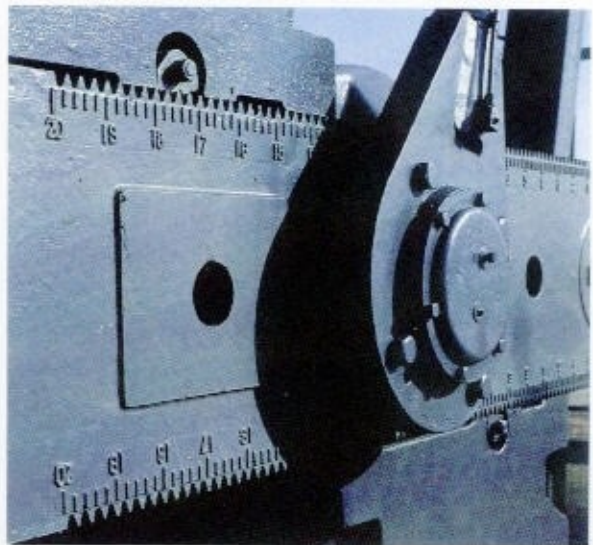

Counterweight Crank

Counterbalance can be easily and safely adjusted by just one person simply by sliding LS's counterweights along the crank arm.

Double Reduction Gear Reducer

The LS PUMPJACK gear reducer is the only pumping unit gearbox that utilizes a cast steel and forged steel combination of gearing. This according to the foremost gear experts in the United States is vastly superior to the combination of cast iron material against steel pinion gears, commonly used by competing pumping unit manufacturers.

In addition the LS gear train is designed with *dual* high-speed gears and pinions insuring even distribution of load about the centerline of the gear box.

The industry's largest shafting and bearings contribute to higher safety factors, while the split gear case design allows operators easier service flexibility.

Our advanced Double Circular Arc (DCA) gear tooth design translates into proven advantages in torque capacity, pitting resistance, tooth bending resistance, and lubrication properties.

Proof of the LS gear reducer's reliability is supported by thousands of pumping units in operation worldwide for over 50 years.

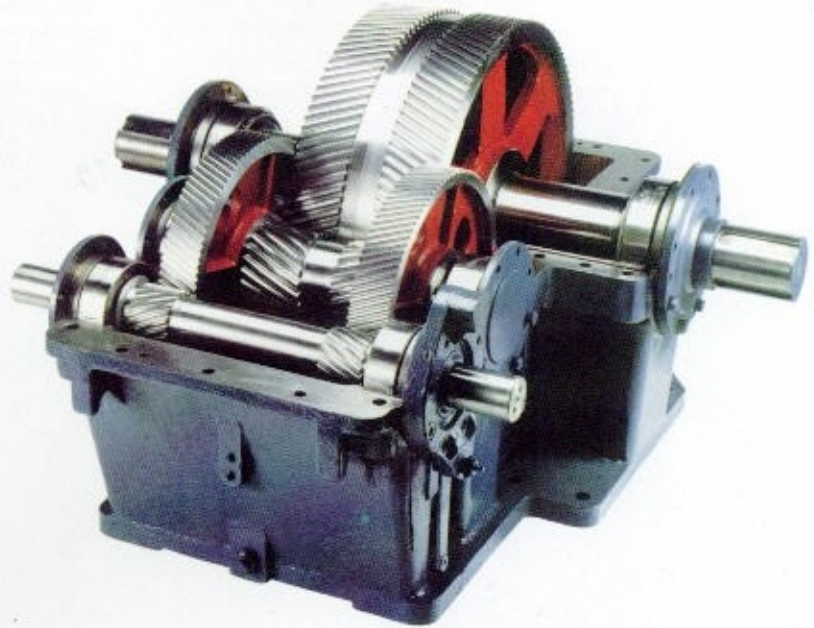

Reducer Model	Peak Torque Rating [Inch-Lbs]	Ratio of Gears	Gear Box Oil Capacity [US Gallons]	Sheave Dimensions	Crankshaft Diameter
1280D	1,280,000	28.85	243	4 ³ / ₄ " Bore. 50", 55"-8C; 40", 48", 50"-6D	8 ²¹ / ₃₂ "
912D	912,000	28.79	180	4 ³ / ₈ " Bore. 50", 55"-8C; 40", 48", 50"-6D	7 ⁷ / ₈ "
640D	640,000	28.36	106	4" Bore. 36", 44", 50"-6C; 48", 50"-4D	7 ⁷ / ₈ "
456D	456,000	28.33	88	4 ⁵ / ₈ " Bore. 36", 44", 50"-6C; 48", 50"-4D	7 ⁷ / ₈ "
320D	320,000	28.81	75	3 ⁵ / ₈ " Bore. 30", 36", 44"-5C	6 ⁷ / ₈ "
228D	228,000	28.87	43	3" Bore. 24", 30", 36"-4C	6 ⁷ / ₈ "
160D	160,000	28.51	37	2 ⁵ / ₈ " Bore. 24", 30", 34"-3C	5 ²⁹ / ₃₂ "
114D	114,000	28.36	25	2 ¹ / ₄ " Bore. 20", 24", 30"-3C	5 ¹ / ₈ "
80D	80,000	28.93	21	2 ¹ / ₁₆ " Bore. 20", 24", 30"-2C	4 ²³ / ₃₂ "

Note: The diameter of sheave and number of belt could be changed as per customers requirements if the condition is allowed.

Gear Reducer Exploded View

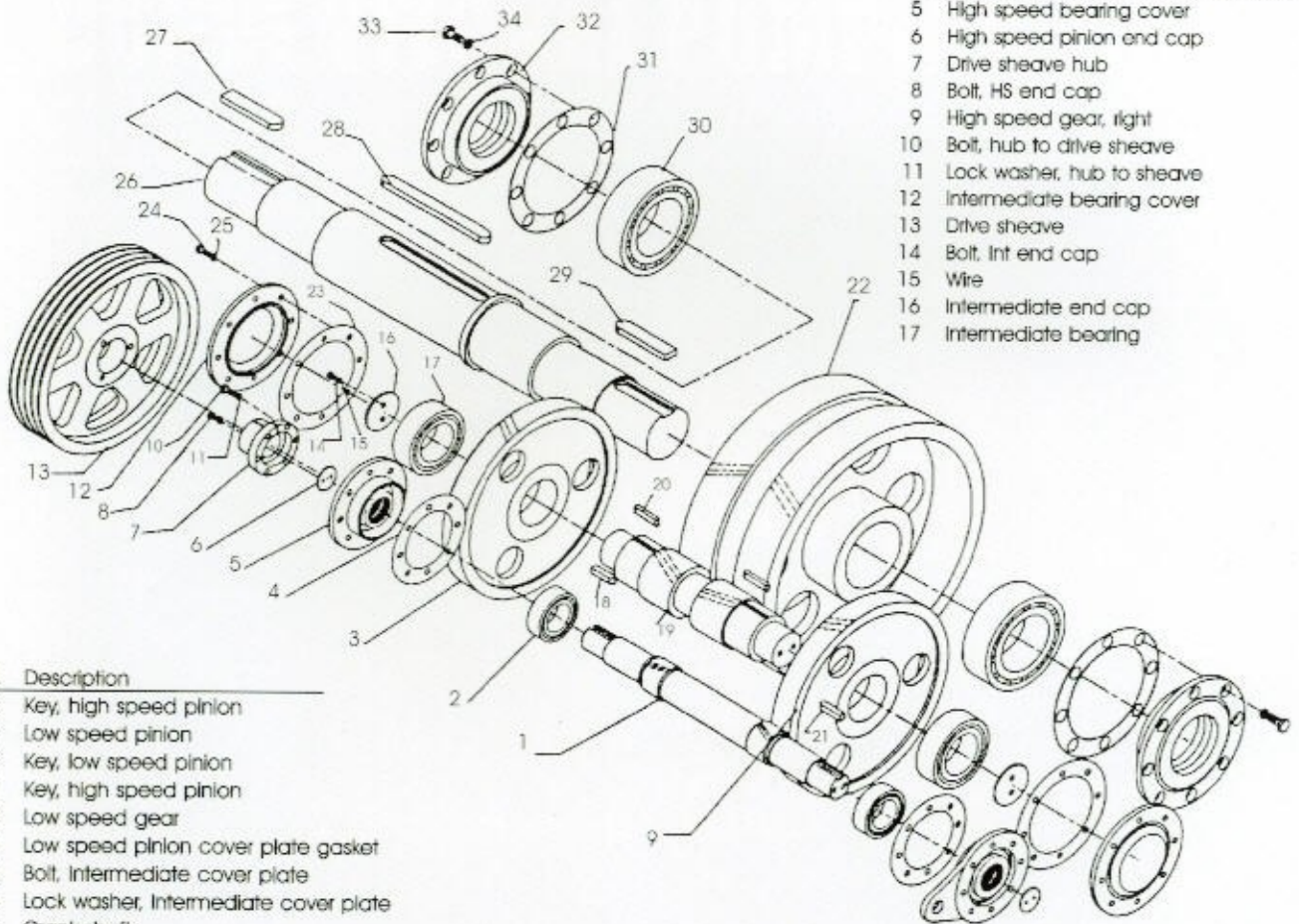

No.	Description
1	High speed pinion
2	High speed bearing
3	High speed gear, left
4	High speed pinion cover plate gasket
5	High speed bearing cover
6	High speed pinion end cap
7	Drive sheave hub
8	Bolt, HS end cap
9	High speed gear, right
10	Bolt, hub to drive sheave
11	Lock washer, hub to sheave
12	Intermediate bearing cover
13	Drive sheave
14	Bolt, Int end cap
15	Wire
16	Intermediate end cap
17	Intermediate bearing

No.	Description
18	Key, high speed pinion
19	Low speed pinion
20	Key, low speed pinion
21	Key, high speed pinion
22	Low speed gear
23	Low speed pinion cover plate gasket
24	Bolt, Intermediate cover plate
25	Lock washer, Intermediate cover plate
26	Crank shaft
27	Key, crank shaft to crank arm
28	Key, crank shaft to slow speed gear
29	Key, crank shaft to crank arm
30	Low speed bearing
31	Crank shaft cover plate gasket
32	Crank shaft cover plate
33	Bolt, crank shaft cover plate
34	Washer, crank shaft cover plate

Bearing Assemblies Exploded Views

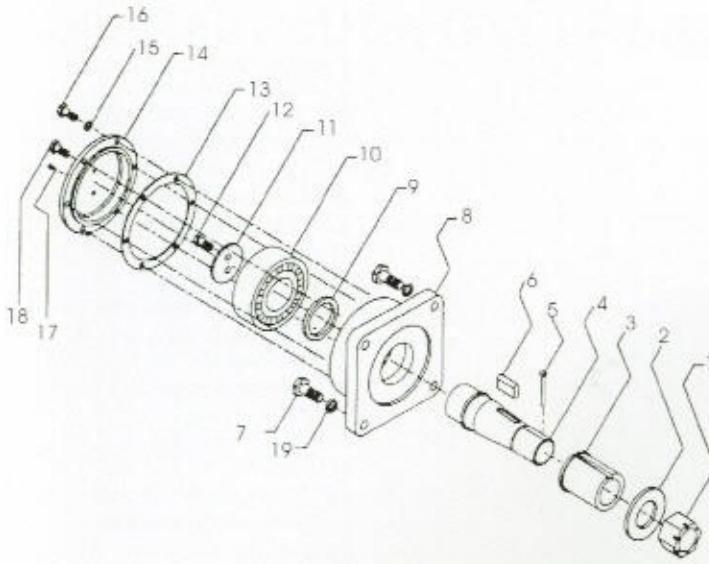

Crank Pin Bearing Assembly

No.	Description
1	Crank pin castle nut
2	Crank pin spacer
3	Crank pin sleeve
4	Crank pin shaft
5	Crank pin cotter pin
6	Crank pin key
7	Crank pin to banjo bolt
8	Crank pin housing
9	Crank pin oil seal
10	Crank pin bearing
11	Crank pin end plate
12	Crank pin end plate bolt
13	Crank pin gasket
14	Crank pin cover plate
15	Crank pin cover plate lock washer
16	Crank pin cover plate bolt
17	Crank pin grease zerk
18	Crank pin grease relief
19	Crank pin to banjo lock washer

Equalizer Bearing Assembly

No.	Description
1	Equalizer bearing housing
2	Equalizer bearing cover plate nut
3	Equalizer bearing cover plate
4	Equalizer bearing gasket
5	Equalizer bearing oil seal
6	Equalizer bearing pin shaft
7	Equalizer bearing
8	Equalizer bearing castle washer
9	Equalizer bearing pin shaft castle nut
10	Equalizer bearing cover plate lock washer
11	Equalizer bearing cover plate bolt
12	Equalizer bearing to walking beam bolt
13	Equalizer bearing to walking beam nut
14	Equalizer bearing to walking beam lock nut

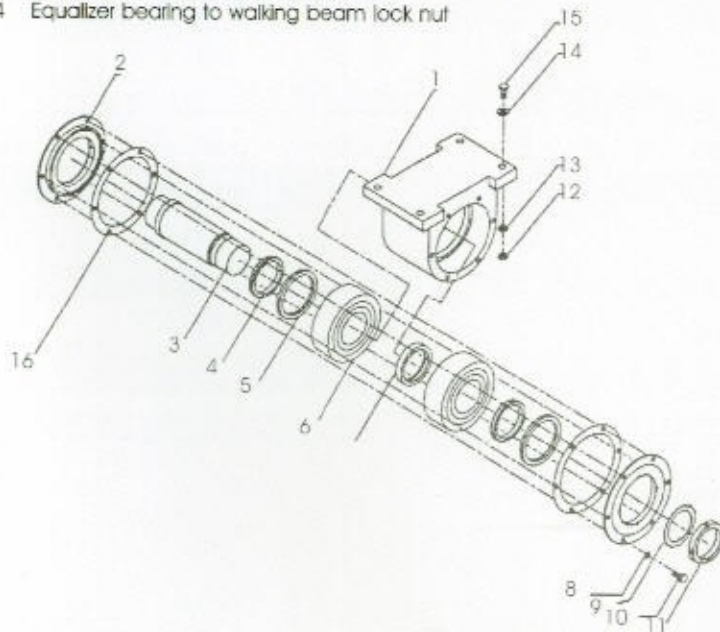
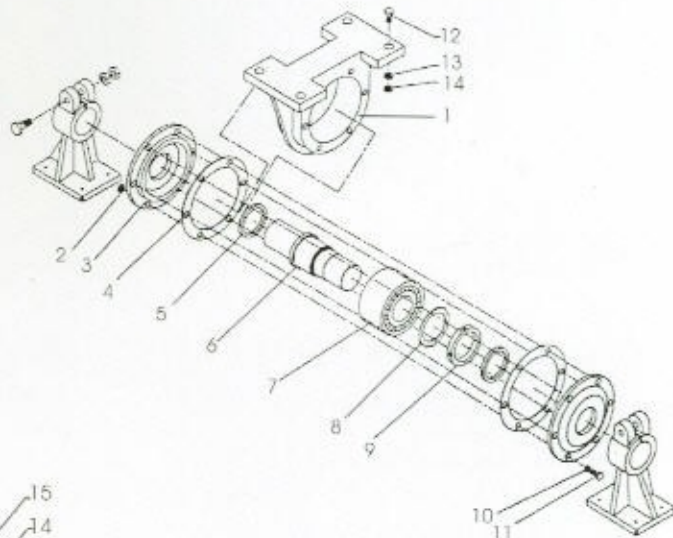

Center Bearing Assembly

No.	Description
1	Center bearing housing
2	Center bearing cover plate
3	Center bearing pin shaft
4	Center bearing sleeve
5	Center bearing oil seal
6	Center bearing
7	Center bearing spacer (between bearings)
8	Center bearing cover plate lock washer
9	Center bearing castle washer
10	Center bearing cover plate bolt
11	Center bearing pin shaft castle nut
12	Center bearing to walking beam lock nut
13	Center bearing to walking beam nut
14	Center bearing to walking beam washer
15	Center bearing to walking beam bolt
16	Center bearing gasket



CONVENTIONAL PUMPING UNIT

API Rear Mounted Geometry Class I Lever System with Crank Counterbalance



Photo: C-912D-365-168
Operating in Montana, USA

CONVENTIONAL PUMPING UNIT

General Specifications

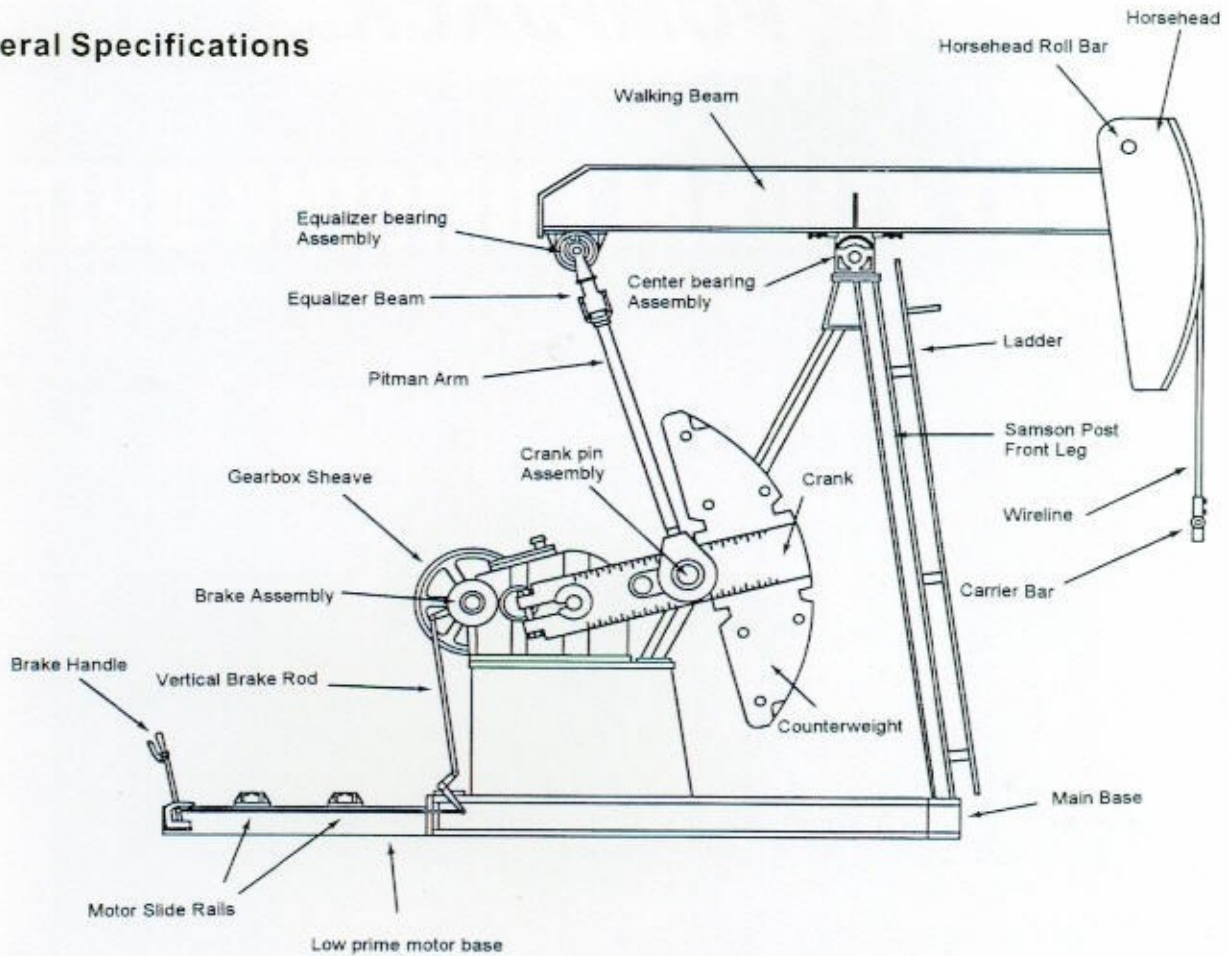

GEAR REDUCER



LS PUMPJACK's Conventional Pumping Units benefit from both the DCA (Double Circular Arc) advanced gear tooth profile of the Gear Reducer and its Conventional Geometry which allows for operation in both directions of rotation (while keeping same mechanical efficiency), insuring long, reliable operating life.

STRUCTURE & BEARINGS



LS PUMPJACK's Conventional Pumping Unit structures are designed as 2-point, enabling loads from the pumping well to be evenly transferred all along the main base. Meanwhile, strong over-designed beams and bearing assemblies ensure loads are softly handled throughout the entire life of the unit.

Unit Designation	Polished Rod Capacity, Lbs.	Stroke Length in Inches
C-1280D-365-192	36,500	192, 165, 138
C-1280D-305-240	30,500	240, 206, 177
C-1280D-365-216	36,500	216, 185, 159
C-1280D-427-192	42,700	192, 165, 138
C-912D-305-240	30,500	240, 206, 177
C-912D-365-192	36,500	192, 165, 138
C-912D-365-168	36,500	168, 144, 121
C-912D-305-168	30,500	168, 144, 121
C-912D-427-144	42,700	144, 123, 102
C-912D-365-144	36,500	144, 123, 102
C-640D-365-168	36,500	168, 144, 121
C-640D-305-168	30,500	168, 144, 121
C-640D-365-144	36,500	144, 123, 102
C-640D-305-144	30,500	144, 123, 102
C-640D-256-144	25,600	144, 122, 101
C-640D-305-120	30,500	120, 102, 84
C-456D-305-168	30,500	168, 144, 121
C-456D-305-144	30,500	144, 123, 102
C-456D-256-144	25,600	144, 122, 101
C-456D-365-120	36,500	120, 102, 84
C-456D-305-120	30,500	120, 102, 84
C-456D-256-120	25,600	120, 102, 84
C-456D-213-120	21,300	120, 102, 84
C-456D-256-100	25,600	100, 85, 70
C-320D-256-144	25,600	144, 122, 101
C-320D-256-120	25,600	120, 102, 84
C-320D-213-120	21,300	120, 102, 84
C-320D-305-100	30,500	100, 85, 70
C-320D-256-100	25,600	100, 85, 70
C-320D-246-86	24,600	86, 74, 62
C-320D-213-86	21,300	86, 74, 62
C-320D-246-74	24,600	74, 64, 53
C-228D-185-144	18,500	144, 122, 101
C-228D-213-120	21,300	120, 102, 84
C-228D-213-100	21,300	100, 86, 72
C-228D-173-100	17,300	100, 86, 72
C-228D-246-86	24,600	86, 74, 62
C-228D-213-86	21,300	86, 74, 62
C-228D-200-74	20,000	74, 64, 53
C-228D-173-74	17,300	74, 64, 53
C-160D-173-100	17,300	100, 86, 72
C-160D-173-86	17,300	86, 74, 62
C-160D-200-74	20,000	74, 64, 53
C-160D-173-74	17,300	74, 62, 51
C-160D-143-74	14,300	74, 62, 51
C-114D-119-100	11,900	100, 86, 72
C-114D-143-86	14,300	86, 72, 58
C-114D-119-86	11,900	86, 72, 58
C-114D-143-74	14,300	74, 62, 51
C-114D-143-64	14,300	64, 55, 44
C-114D-173-64	17,300	64, 55, 44
C-114D-119-64	11,900	64, 53, 41

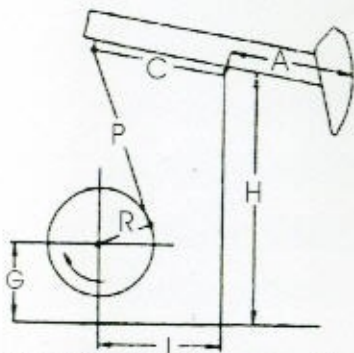

Conventional Pumping Unit
API Linkage Nomenclature

CONVENTIONAL PUMPING UNITS-APILinkage Table

UNIT MODEL	A	C	P	H	I	G	R1	R2	R3	SU	T.F. @ 90° / Max. Stroke
C-1280D-365-192	206.9	120.1	159.8	274	120.1	114.2	53.5	46.5	39.4	-689	90.1
C-1280D-305-240	222.6	120.1	212.6	324.8	120.1	112.2	61.4	53.5	46.5	-1340	111.7
C-1280D-365-216	200	120.1	189	301.2	120.1	112.2	61.4	53.5	46.5	-930	99.78
C-1280D-427-192	206.9	120.1	159.8	274	120.1	112.2	53.5	46.5	39.4	-700	90.1
C-912D-305-240	222.6	120.1	212.6	324.8	120.1	112.2	61.4	53.5	46.5	-1340	111.7
C-912D-365-192	206.9	120.1	159.8	274	120.1	114.2	53.5	46.5	39.4	-689	90.1
C-912D-305-192	209.9	120.1	159.8	274	120.1	114.2	53.5	46.5	39.4	-868	90.1
C-912D-365-168	181.1	120.1	149.6	263.4	120.1	113.8	53.5	46.5	39.4	-69	78.59
C-912D-305-168	181.1	120.1	149.6	263.4	120.1	113.8	53.5	46.5	39.4	-60	78.59
C-912D-427-144	181.1	120.1	149.6	255.9	120.1	106.3	46.5	40	33.5	750	68.83
C-912D-365-144	181.1	120.1	149.6	255.9	120.1	106.3	46.5	40	33.5	685	68.83
C-640D-305-192	206.9	120.1	159.8	274	120.1	114.2	53.5	46.5	39.4	-855	90.1
C-640D-365-168	181.1	120.1	149.6	263.4	120.1	113.8	53.5	46.5	39.4	-69	78.59
C-640D-305-168	181.1	120.1	149.6	263.4	120.1	113.8	53.5	46.5	39.4	-54	78.59
C-640D-365-144	181.1	120.1	149.6	255.9	120.1	106.3	46.5	40	33.5	-677	68.83
C-640D-305-144	181.1	120.1	149.6	255.9	120.1	106.3	46.5	40	33.5	-550	68.83
C-640D-256-144	185.2	111	133.9	231.5	111	96.5	41.9	35.8	29.7	-390	68.65
C-640D-305-120	154.5	111	133.9	231.5	111	96.5	41.9	35.8	29.7	65	57.33
C-456D-256-192	206.9	120.1	159.8	274	120.1	114.2	53.5	46.5	39.4	-876	90.1
C-456D-305-168	181.1	120.1	149.6	263.4	120.1	113.8	53.5	46.5	39.4	-277	78.59
C-456D-305-144	181.1	120.1	149.6	255.9	120.1	106.3	46.5	40	33.5	550	68.83
C-456D-256-144	185.2	111	133.9	231.5	111	96.5	41.9	35.8	29.7	-400	68.65
C-456D-365-120	154.53	111	133.9	231.5	111	96.5	41.9	35.8	29.7	67	57.33
C-456D-305-120	154.53	111	133.9	231.5	111	96.5	41.9	35.8	29.7	60	57.33
C-456D-256-120	154.53	111	133.9	231.5	111	96.5	41.9	35.8	29.7	140	57.33
C-456D-213-120	154.53	111	133.9	231.5	111	96.5	41.9	35.8	29.7	45	57.33
C-456D-256-100	129.1	111	133.9	231.5	111	96.5	41.9	35.8	29.7	882	47.91
C-320D-256-144	185.2	111	133.9	231.5	111	96.5	41.9	35.8	29.7	-410	68.73
C-320D-213-144	185.2	111	133.9	231.5	111	96.5	41.9	35.8	29.7	-410	68.73
C-320D-256-120	154.5	111	133.9	231.5	111	96.5	41.9	35.8	29.7	70	57.33
C-320D-213-120	154.5	111	133.9	231.5	111	96.5	41.9	35.8	29.7	35	57.33
C-320D-305-100	129.1	111	133.9	231.5	111	96.5	41.9	35.8	29.7	882	47.91
C-320D-256-100	129.1	111	133.9	231.5	111	96.5	41.9	35.8	29.7	882	47.91
C-320D-246-86	111	96.1	116.1	194.9	96.1	78.8	36.2	31.3	26.4	627	41.13
C-320D-213-86	111	96.1	116.1	194.9	96.1	78.8	36.2	31.3	26.4	615	41.13
C-320D-246-74	96.1	96.1	116.1	194.9	96.1	78.8	36.2	31.3	26.4	850	35.59
C-228D-185-144	185.2	111	133.9	231.5	111	96.5	41.9	35.8	29.7	-580	68.73
C-228D-213-120	154.5	111	133.9	231.5	111	96.5	41.9	35.8	29.7	35	57.33
C-228D-213-100	129.1	96.1	116.1	194.9	96.1	78.8	36.2	31.3	26.4	83	47.84
C-228D-173-100	129.1	96.1	116.1	194.9	96.1	78.8	36.2	31.3	26.4	96	47.84
C-228D-246-86	111	96.1	116.1	194.9	96.1	78.8	36.2	31.3	26.4	630	41.13
C-228D-213-86	111	96.1	116.1	194.9	96.1	78.8	36.2	31.3	26.4	617	41.13
C-228D-200-74	96.1	96.1	116.1	194.9	96.1	78.8	36.2	31.3	26.4	870	35.59
C-228D-173-74	96.1	96.1	116.1	194.9	96.1	78.8	36.2	31.3	26.4	850	35.59
C-160D-173-100	129.1	96.1	116.1	194.9	96.1	78.8	36.2	31.3	26.4	300	47.84
C-160D-173-86	111	96.1	116.1	194.9	96.1	78.8	36.2	31.3	26.4	615	41.13
C-160D-200-74	96.1	96.1	116.1	194.9	96.1	78.8	36.2	31.3	26.4	873	35.59
C-160D-173-74	96.1	84	96.5	165.7	84	69.2	31.7	26.8	21.9	830	35.52
C-160D-143-74	96.1	84	96.5	165.7	84	69.2	31.7	26.8	21.9	668	35.52
C-114D-119-100	129.1	96.1	116.1	194.9	96.1	78.8	36.2	31.3	26.4	77	47.84
C-114D-143-86	111	84	96.5	165.7	84	69.2	31.7	26.8	21.9	305	41.05
C-114D-119-86	111	84	96.5	165.7	84	69.2	31.7	26.8	21.9	305	41.05
C-114D-143-74	96.1	84	96.5	165.7	84	69.2	31.7	26.8	21.9	660	35.52
C-114D-143-64	84	84	96.5	165.7	84	69.2	31.7	26.8	21.9	440	31.08
C-114D-173-64	84	84	96.5	165.7	84	69.2	31.7	26.8	21.9	440	31.08
C-114D-119-64	84	64	74.8	128	64	53.2	24	19.7	15.4	36	30.97

Dimensions subject to change without notice.

CONVENTIONAL PUMPING UNITS-Maximum ECB(Effective Conterbalance)Table

UNIT MODEL	Crank Name	ECB Cranks-only	ECB for LS Counterweight Sizes								
			No. 1	No. 2	No. 3	No. 4	No. 5	No. 6	No. 7	No. 8	No. 9
C-1280D-365-192	4354	3,967	22,559	19,029	17,257	16,014	14,188	12,337	10,455	8,464	7,116
C-1280D-365-168	4354	5,559	26,822	22,784	20,757	19,336	17,248	15,131	12,979	10,701	9,160
C-1280D-305-168	4354	5,573	26,886	22,839	20,808	19,383	17,290	15,168	13,011	10,728	9,183
C-1280D-427-144	4045	5,784	-	23,608	21,569	20,093	17,925	15,751	13,535	11,175	9,568
C-1280D-365-144	4045	5,784	-	23,608	21,569	20,093	17,925	15,751	13,535	11,175	9,568
C-912D-365-192	4354	4,346	22,915	19,389	17,619	16,377	14,554	12,705	10,826	8,837	7,491
C-912D-365-168	4354	5,942	27,179	23,146	21,122	19,702	17,617	15,503	13,353	11,078	9,539
C-912D-305-168	4354	5,942	27,179	23,146	21,122	19,702	17,617	15,503	13,353	11,078	9,539
C-912D-427-144	4045	5,784	-	23,608	21,569	20,093	17,925	15,751	13,535	11,175	9,568
C-912D-365-144	4045	5,784	-	23,608	21,569	20,093	17,925	15,751	13,535	11,175	9,568
C-640D-365-168	4354	5,898	27,211	23,164	21,133	19,708	17,615	15,493	13,336	11,053	9,508
C-640D-305-168	4354	5,788	27,101	23,054	21,023	19,598	17,505	15,383	13,226	10,943	9,398
C-640D-365-144	4045	5,784	-	23,608	21,569	20,093	17,925	15,751	13,535	11,175	9,568
C-640D-305-144	4045	5,518	-	23,342	21,303	19,827	17,659	15,485	13,269	10,909	9,302
C-640D-256-144	4045	5,298	-	23,122	21,084	19,607	17,439	15,265	13,049	10,689	9,083
C-640D-305-120	3064	5,372	-	24,189	22,301	20,732	18,404	16,104	13,751	11,226	9,494
C-456D-305-168	4354	5,573	26,886	22,839	20,808	19,383	17,290	15,168	13,011	10,728	9,183
C-456D-305-144	3064	3,821	-	*19,570	*17,989	16,676	14,728	12,803	10,834	8,720	7,270
C-456D-256-144	4045	5,298	-	23,122	21,084	19,607	17,439	15,265	13,049	10,689	9,083
C-456D-365-120	3064	5,496	-	*24,355	*22,464	20,906	18,571	16,264	13,903	11,369	9,632
C-456D-305-120	3064	5,391	-	*24,258	*22,367	20,808	18,472	16,163	13,801	11,266	9,528
C-456D-256-120	3064	4,667	-	*23,484	*21,596	20,027	17,699	15,399	13,046	10,521	8,789
C-456D-213-120	3064	4,747	-	*23,564	*21,676	20,107	17,779	15,479	13,126	10,601	8,869
C-456D-256-100	3064	6,961	-	*29,571	*27,302	25,417	22,620	19,856	17,029	13,995	11,941
C-320D-119-168	3064	2,621	-	*16,133	*14,777	13,650	11,979	10,328	8,638	6,825	5,581
C-320D-256-144	3064	3,726	-	*19,506	*17,922	16,606	14,655	12,726	10,753	8,635	7,182
C-320D-213-144	3064	3,192	-	*18,768	*17,204	15,906	13,979	12,075	10,128	8,038	6,604
C-320D-119-144	3064	3,223	-	*18,913	*17,339	16,030	14,090	12,172	10,210	8,104	6,660
C-320D-256-120	3064	4,670	-	*23,499	*21,609	20,040	17,711	15,409	13,055	10,528	8,794
C-320D-213-120	3064	4,679	-	*23,235	*21,372	19,825	17,530	15,262	12,942	10,451	8,743
C-320D-305-100	3064	6,960	-	*29,584	*27,313	25,427	22,629	19,863	17,034	13,998	11,915
C-320D-256-100	3064	6,956	-	*29,566	*27,297	25,412	22,615	19,851	17,024	13,990	11,909
C-320D-246-86	1940	4,432	-	-	-	-	17,968	15,697	13,344	10,748	8,921
C-320D-213-86	1940	3,828	-	-	-	-	17,310	15,049	12,704	10,120	8,300
C-320D-246-74	1940	5,041	-	-	-	-	20,629	18,014	15,304	12,315	10,211
C-228D-185-144	3064	3,630	-	-	-	-	14,643	12,699	10,711	8,577	7,113
C-228D-213-120	3064	4,747	-	19,721	17,949	16,610	17,779	15,479	13,126	10,601	8,869
C-228D-213-100	1940	3,564	-	*23,564	*21,676	20,107	15,165	13,218	11,201	8,977	7,412
C-228D-173-100	1940	3,029	-	-	-	-	14,629	12,682	10,666	8,442	6,876
C-228D-246-86	1940	4,398	-	-	-	-	17,880	15,619	13,274	10,690	8,870
C-228D-213-86	1940	3,828	-	-	-	-	17,310	15,049	12,704	10,120	8,300
C-228D-200-74	1940	5,041	-	-	-	-	20,629	18,014	15,304	12,315	10,211
C-228D-173-74	1940	5,041	-	-	-	-	20,629	18,014	15,304	12,315	10,211
C-160D-119-120	1940	2,077	-	-	-	-	11,732	10,112	8,433	6,582	5,279
C-160D-173-100	1940	2,969	-	-	-	-	14,570	12,624	10,607	8,383	6,817
C-160D-173-86	1940	3,809	-	-	-	-	17,291	15,029	12,685	10,100	8,281
C-160D-200-74	1940	5,019	-	-	-	-	20,607	17,992	15,281	12,293	10,189
C-160D-173-74	1587	2,219	-	-	-	-	*14,802	*13,388	11,704	9,312	7,586
C-160D-143-74	1587	3,219	-	-	-	-	*14,802	13,388	11,704	9,312	7,586
C-114D-119-100	1940	2,991	-	-	-	-	14,592	12,646	10,629	8,405	6,839
C-114D-143-86	1587	3,166	-	-	-	-	13,998	12,271	10,456	8,401	6,918
C-114D-119-86	1587	3,515	-	-	-	-	-	-	9,853	7,784	6,291
C-114D-143-74	1587	3,219	-	-	-	-	-	-	11,704	9,312	7,586
C-114D-173-64	1587	3,651	-	-	-	-	-	-	13,349	10,615	8,642
C-114D-143-64	1587	4,113	-	-	-	-	-	-	15,346	12,179	9,894

All Values Shown in Lbs. of Effective Counterbalance (ECB) at Polish Rod w/ Four Weights At Maximum Position on Crank, at Longest Stroke Length

*Maximum ECB achieved with Counterweight positioned not at end of crank arm.
Contact LS Petrochem Equipment for counterweight maximum position on crank.

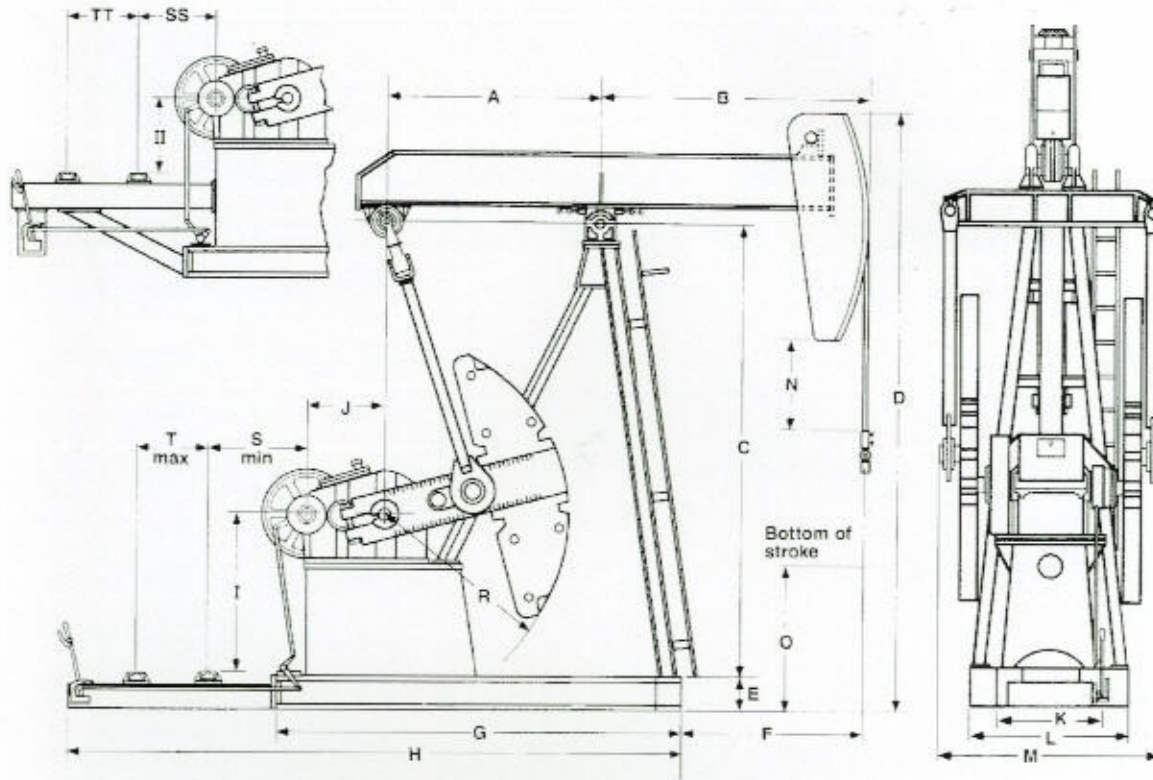

CONVENTIONAL PUMPING UNITS - General Dimensions

UNIT MODEL	A	B	C	D	E	F	G	H	I	J	K	L	M	N	O	R	II	S	SS	TT	
C-1280D-365-192	10'	17'-3"	21'	31'-3"	22"	13-1/4"	20'-4 1/2"	29'-5"	98 1/2"	52 1/2"	51 1/2"	76"	111 1/2"	20"	50"	110"	47 1/2"	62"	48"	26 1/2"	50 1/2"
C-1280D-305-240	10'	18'-6 1/2"	25'-2 1/2"	37'-3 1/2"	22"	13-11 1/2"	19'-11 1/2"	29'-5"	98 1/2"	52 1/2"	51 1/2"	76"	111 1/2"	20"	54"	110"	47 1/2"	62"	48"	26 1/2"	50 1/2"
C-1280D-365-216	10'	16'-8"	23'-3 1/2"	34'-4 1/2"	22"	12-7/8"	19'-11 1/2"	29'-5"	93 3/4"	52 1/2"	51 1/2"	76"	111 1/2"	20"	54"	110"	47 1/2"	62"	48"	26 1/2"	50 1/2"
C-1280D-427-192	10'	17'-3"	21'	31'-3"	22"	13-1 1/4"	19'-5 1/2"	29'-5"	96 1/2"	52 1/2"	51 1/2"	76"	111 1/2"	20"	50"	110"	47 1/2"	62"	48"	26 1/2"	50 1/2"
C-912D-305-240	10'	18'-6 1/2"	25'-2 1/2"	37'-3 1/2"	22"	13-11 1/2"	19'-7 1/2"	29'-5"	96 1/2"	48 1/2"	51 1/2"	76"	109 1/2"	20"	54"	110"	47 1/2"	62"	48"	26 1/2"	50 1/2"
C-912D-365-192	10'	17'-3"	21'	31'-3"	22"	13-1 1/4"	20'-1 1/2"	29'-1 1/2"	96 1/2"	48 1/2"	51 1/2"	76"	109 1/2"	20"	50"	110"	47 1/2"	62"	48"	26 1/2"	50 1/2"
C-912D-305-192	10'	17'-3"	21'	31'-3"	22"	13-2 1/2"	19'-7 1/2"	30'-6 1/2"	96 1/2"	48 1/2"	51 1/2"	76"	109 1/2"	20"	48 1/2"	110"	47 1/2"	62"	48"	26 1/2"	50 1/2"
C-912D-365-168	10'	15'-1"	20'-5 1/2"	29'-5 1/2"	17 1/2"	11-1 1/2"	20'-1 1/2"	29'-1 1/2"	98"	48 1/2"	51 1/2"	72"	109 1/2"	20"	81"	110"	47 1/2"	62"	48"	26 1/2"	50 1/2"
C-912D-305-168	10'	15'-1"	20'-5 1/2"	29'-5 1/2"	17 1/2"	11-1"	20'-1 1/2"	29'-1"	98"	48 1/2"	51 1/2"	72"	109 1/2"	20"	81"	110"	47 1/2"	62"	48"	26 1/2"	50 1/2"
C-912D-427-144	10'	15'-1"	19'-10 1/2"	27'-12"	17 1/2"	11-3/8"	20'-1 1/2"	29'-1 1/2"	90 1/2"	48 1/2"	51 1/2"	72"	109 1/2"	20"	73"	102 1/2"	47 1/2"	62"	48"	26 1/2"	50 1/2"
C-912D-365-144	10'	15'-1"	19'-10 1/2"	27'-12"	17 1/2"	11-1 1/2"	20'-1 1/2"	29'-1"	90 1/2"	48 1/2"	51 1/2"	72"	109 1/2"	20"	73"	102 1/2"	47 1/2"	62"	48"	26 1/2"	50 1/2"
C-640D-305-192	10'	17'-3"	21'-4 1/2"	31'-3"	17 1/2"	13-2 1/2"	19'-5 1/2"	28'-6 1/2"	96 1/2"	41 1/2"	51 1/2"	76"	106"	20"	50"	110"	52"	62"	48"	26 1/2"	50 1/2"
C-640D-365-168	10'	15'-1"	20'-5 1/2"	29'-5 1/2"	17 1/2"	11-1 1/2"	10'-5 1/2"	28'-5 1/2"	98"	41 1/2"	51 1/2"	72"	106"	20"	81"	110"	52"	62"	48"	26 1/2"	50 1/2"
C-640D-305-168	10'	15'-1"	20'-5 1/2"	29'-5 1/2"	17 1/2"	11-1"	19'-5"	28'-5"	98"	41 1/2"	51 1/2"	72"	106"	20"	81"	110"	52"	62"	48"	26 1/2"	50 1/2"
C-640D-365-144	10'	15'-1"	19'-10 1/2"	27'-12"	17 1/2"	8-11 1/2"	19'-5"	28'-5"	90 1/2"	41 1/2"	51 1/2"	72"	106"	20"	73"	102 1/2"	52"	62"	48"	26 1/2"	50 1/2"
C-640D-305-144	10'	15'-1"	19'-10 1/2"	27'-12"	17 1/2"	11-1"	19'-5"	28'-5"	90 1/2"	41 1/2"	51 1/2"	72"	104 1/2"	20"	73"	102 1/2"	52"	62"	48"	26 1/2"	50 1/2"
C-640D-256-144	9'-3"	15'-5 1/2"	17'-11 1/2"	25'-8 1/2"	15 1/2"	11-10 1/2"	18'-6 1/2"	26'-9"	82 1/2"	41 1/2"	47 1/2"	69 1/2"	101"	20"	73"	94 1/2"	53"	62"	48"	26 1/2"	37 1/2"
C-640D-305-120	9'-3"	12'-10 1/2"	17'-11 1/2"	25'	15 1/2"	9-3 1/2"	18'-6 1/2"	26'-9"	82 1/2"	41 1/2"	47 1/2"	69 1/2"	101"	20"	79"	94 1/2"	53"	62"	48"	26 1/2"	37 1/2"

NOTE: Do not use above dimensions for foundation. Request foundation plan.

CONVENTIONAL PUMPING UNITS - General Dimensions (continued)

UNIT MODEL	A	B	C	D	E	F	G	H	I	J	K	L	M	N	O	R	II	S	T	SS	TT
C-456D-256-192	10'	17'-3"	21'-4 1/2"	31'-3"	17 1/2"	13'-2 1/2"	19'-2"	27'-4"	98 1/2"	38 1/2"	47 1/2"	76"	103 1/2"	20"	50"	110"	52"	62"	48"	26 1/2"	50 1/2"
C-456D-305-168	10'	15'-1"	20'-5 1/2"	29'-5 1/2"	17 1/2"	11'-1"	19'-2"	27'-4"	98"	38 1/2"	47 1/2"	72"	103 1/2"	20"	81"	110"	52"	62"	48"	26 1/2"	50 1/2"
C-456D-305-144	10'	15'-1"	19'-10 1/2"	27'-12"	17 1/2"	11'-10 1/2"	19'-2"	27'-4"	98"	38 1/2"	47 1/2"	72"	102"	20"	73"	102 1/2"	52"	62"	48"	26 1/2"	50 1/2"
C-456D-256-144	9'-3"	15'-5 1/2"	17'-11 1/2"	25'-8 1/2"	15 1/2"	11'-10 1/2"	18'-5"	26'-1"	82 1/2"	38 1/2"	43 1/2"	69 1/2"	98"	20"	51"	94 1/2"	53"	62"	48"	26 1/2"	37 1/2"
C-456D-365-120	9'-3"	12'-10 1/2"	17'-11 1/2"	25'	15 1/2"	9'-3 1/2"	18'-5"	26'-1"	82 1/2"	38 1/2"	43 1/2"	69 1/2"	102"	20"	79"	94 1/2"	53"	62"	48"	26 1/2"	37 1/2"
C-456D-305-120	9'-3"	12'-10 1/2"	17'-11 1/2"	25'	15 1/2"	9'-3 1/2"	18'-5"	26'-1"	82 1/2"	38 1/2"	43 1/2"	69 1/2"	98"	20"	79"	94 1/2"	53"	62"	48"	26 1/2"	37 1/2"
C-456D-256-120	9'-3"	12'-10 1/2"	17'-11 1/2"	25'	15 1/2"	9'-3 1/2"	18'-5"	26'-1"	82 1/2"	38 1/2"	43 1/2"	69 1/2"	98"	20"	79"	94 1/2"	53"	62"	48"	26 1/2"	37 1/2"
C-456D-213-120	9'-3"	12'-10 1/2"	17'-11 1/2"	25'	15 1/2"	9'-3 1/2"	18'-5"	26'-1"	82 1/2"	38 1/2"	43 1/2"	69 1/2"	98"	20"	79"	94 1/2"	53"	62"	48"	26 1/2"	37 1/2"
C-456D-256-100	9'-3"	10'-9 1/2"	17'-11 1/2"	24'	15 1/2"	7'-2 1/2"	18'-5"	26'-1"	82 1/2"	38 1/2"	43 1/2"	69 1/2"	98"	20"	94"	94 1/2"	53"	62"	48"	27 1/2"	34 1/2"
C-320D-256-144	9'-3"	15'-5 1/2"	17'-11 1/2"	25'-8 1/2"	15 1/2"	11'-10 1/2"	18'-2 1/2"	25'-11"	82 1/2"	37 1/2"	43 1/2"	69 1/2"	92 1/2"	20"	51"	94 1/2"	53"	62"	48"	30 1/2"	34 1/2"
C-320D-213-144	9'-3"	15'-5 1/2"	17'-11 1/2"	25'-8 1/2"	15 1/2"	11'-10 1/2"	18'-2 1/2"	25'-11"	82 1/2"	37 1/2"	43 1/2"	69 1/2"	92 1/2"	20"	51"	94 1/2"	53"	62"	48"	30 1/2"	34 1/2"
C-320D-256-120	9'-3"	12'-10 1/2"	17'-11 1/2"	25'	15 1/2"	9'-3 1/2"	18'-2 1/2"	25'-11"	82 1/2"	37 1/2"	43 1/2"	69 1/2"	92 1/2"	20"	79"	94 1/2"	53"	52"	48"	30 1/2"	34 1/2"
C-320D-213-120	9'-3"	12'-10 1/2"	17'-11 1/2"	25'	15 1/2"	9'-3 1/2"	18'-2 1/2"	25'-11"	82 1/2"	37 1/2"	43 1/2"	69 1/2"	92 1/2"	20"	79"	94 1/2"	53"	52"	48"	30 1/2"	34 1/2"
C-320D-305-100	9'-3"	10'-9 1/2"	17'-11 1/2"	24'	15 1/2"	7'-2 1/2"	18'-2 1/2"	25'-11"	82 1/2"	37 1/2"	43 1/2"	69 1/2"	92 1/2"	20"	94"	94 1/2"	53"	52"	48"	30 1/2"	34 1/2"
C-320D-256-100	9'-3"	10'-9 1/2"	17'-11 1/2"	24'	15 1/2"	7'-2 1/2"	18'-2 1/2"	25'-11"	82 1/2"	37 1/2"	43 1/2"	69 1/2"	92 1/2"	20"	94"	94 1/2"	53"	52"	48"	30 1/2"	34 1/2"
C-320D-246-86	8'	9'-3"	15'-3 1/2"	20'-6"	14 1/2"	5'-11 1/2"	16'-3"	23'-11 1/2"	65 1/2"	37 1/2"	36 1/2"	56 1/2"	90 1/2"	20"	72"	76 1/2"	36"	50"	45 1/2"	30 1/2"	34 1/2"
C-320D-213-86	8'	9'-3"	15'-3 1/2"	20'-6"	14 1/2"	5'-11 1/2"	16'-3"	23'-11 1/2"	65 1/2"	37 1/2"	36 1/2"	56 1/2"	90 1/2"	20"	72"	76 1/2"	36"	50"	45 1/2"	30 1/2"	34 1/2"
C-320D-246-74	8'	8'	15'-3 1/2"	20'-3 1/2"	14 1/2"	4'-8 1/2"	16'-3"	23'-11 1/2"	65 1/2"	37 1/2"	36 1/2"	56 1/2"	90 1/2"	20"	83"	76 1/2"	36"	50"	45 1/2"	30 1/2"	34 1/2"
C-228D-185-144	9'-3"	15'-5 1/2"	17'-11 1/2"	25'-8 1/2"	15 1/2"	11'-10 1/2"	17'-11"	25'-7 1/2"	82 1/2"	33 1/2"	36 1/2"	69 1/2"	84 1/2"	20"	51"	94 1/2"	53"	50"	45 1/2"	27 1/2"	34 1/2"
C-228D-213-120	9'-3"	12'-10 1/2"	17'-11 1/2"	25'	15 1/2"	9'-3 1/2"	15'-11"	25'-7 1/2"	82 1/2"	33 1/2"	36 1/2"	69 1/2"	84 1/2"	20"	79"	94 1/2"	53"	50"	45 1/2"	27 1/2"	34 1/2"
C-228D-213-100	8'	10'-9 1/2"	15'-3 1/2"	21'-1"	14 1/2"	7'-5 1/2"	15'-11"	23'-7 1/2"	65 1/2"	33 1/2"	36 1/2"	56 1/2"	83 1/2"	20"	58"	76 1/2"	36"	50"	45 1/2"	27 1/2"	34 1/2"
C-228D-173-100	8'	10'-9 1/2"	15'-3 1/2"	21'-1"	14 1/2"	7'-5 1/2"	15'-11"	23'-7 1/2"	65 1/2"	33 1/2"	36 1/2"	56 1/2"	83 1/2"	20"	58"	76 1/2"	36"	50"	45 1/2"	27 1/2"	34 1/2"
C-228D-246-86	8'	9'-3"	15'-3 1/2"	20'-6"	14 1/2"	5'-11 1/2"	15'-11"	23'-7 1/2"	65 1/2"	33 1/2"	36 1/2"	56 1/2"	83 1/2"	20"	72"	76 1/2"	36"	50"	45 1/2"	27 1/2"	34 1/2"
C-228D-213-86	8'	9'-3"	15'-3 1/2"	20'-6"	14 1/2"	5'-11 1/2"	15'-11"	23'-7 1/2"	65 1/2"	33 1/2"	36 1/2"	56 1/2"	83 1/2"	20"	72"	76 1/2"	36"	50"	45 1/2"	27 1/2"	34 1/2"
C-228D-200-74	8'	8'	15'-3 1/2"	20'-3 1/2"	14 1/2"	4'-8 1/2"	15'-11"	23'-7 1/2"	65 1/2"	33 1/2"	36 1/2"	56 1/2"	83 1/2"	20"	83"	76 1/2"	36"	50"	45 1/2"	27 1/2"	34 1/2"
C-228D-173-74	8'	8'	15'-3 1/2"	20'-3 1/2"	14 1/2"	4'-8 1/2"	15'-11"	23'-7 1/2"	65 1/2"	33 1/2"	36 1/2"	56 1/2"	83 1/2"	20"	83"	76 1/2"	36"	50"	45 1/2"	27 1/2"	34 1/2"
C-160D-173-100	8'	10'-9 1/2"	15'-3 1/2"	21'-1"	14 1/2"	7'-6"	15'-7"	22'-1 1/2"	65 1/2"	29 1/2"	33 1/2"	56 1/2"	80 1/2"	20"	58"	76 1/2"	38"	45"	43"	26 1/2"	34 1/2"
C-160D-173-86	8'	9'-3"	15'-3 1/2"	20'-6"	14 1/2"	5'-11 1/2"	15'-7"	22'-1 1/2"	65 1/2"	29 1/2"	33 1/2"	56 1/2"	80 1/2"	20"	72"	76 1/2"	38"	45"	43"	26 1/2"	34 1/2"
C-160D-200-74	8'	8'	15'-3 1/2"	20'-3 1/2"	14 1/2"	4'-8 1/2"	15'-7"	22'-1 1/2"	65 1/2"	29 1/2"	33 1/2"	56 1/2"	80 1/2"	20"	83"	76 1/2"	38"	45"	43"	26 1/2"	34 1/2"
C-160D-173-74	7'	8'	12'-10"	17'-7 1/2"	11 1/2"	5'-2 1/2"	14'-1"	20'-7 1/2"	58"	29 1/2"	33 1/2"	51 1/2"	78 1/2"	20"	54"	67"	29"	45"	43"	26 1/2"	34 1/2"
C-160D-143-74	7'	8'	12'-10"	17'-7 1/2"	11 1/2"	5'-2 1/2"	14'-1"	20'-7 1/2"	58"	29 1/2"	33 1/2"	51 1/2"	78 1/2"	20"	54"	67"	29"	45"	43"	26 1/2"	34 1/2"
C-114D-119-100	8'	10'-9 1/2"	15'-3 1/2"	21'-1"	14 1/2"	7'-6 1/2"	15'-2 1/2"	21'-9"	65 1/2"	25 1/2"	33 1/2"	56 1/2"	73"	20"	58"	76 1/2"	38"	45"	43"	26 1/2"	34 1/2"
C-114D-143-86	7'	9'-3"	12'-10"	18'-1"	11 1/2"	6'-5 1/2"	13'-9 1/2"	20'-4 1/2"	58"	25 1/2"	33 1/2"	51 1/2"	73"	13"	50"	67"	29"	45"	43"	23"	34 1/2"
C-114D-119-86	7'	9'-3"	12'-10"	18'-1"	11 1/2"	6'-5 1/2"	13'-9 1/2"	20'-4 1/2"	58"	25 1/2"	33 1/2"	51 1/2"	73"	13"	50"	67"	29"	45"	43"	23"	34 1/2"
C-114D-143-74	7'	8'	12'-10"	17'-7 1/2"	11 1/2"	5'-2 1/2"	13'-9 1/2"	20'-4 1/2"	58"	25 1/2"	33 1/2"	51 1/2"	73"	20"	54"	67"	29"	45"	43"	23"	34 1/2"
C-114D-143-64	7'	7'	12'-10"	17'-2 1/2"	11 1/2"	4'-2 1/2"	13'-9 1/2"	20'-4 1/2"	58"	25 1/2"	33 1/2"	51 1/2"	73"	20"	63"	67"	29"	45"	43"	23"	34 1/2"
C-114D-173-64	7'	7'	12'-10"	17'-2 1/2"	11 1/2"	4'-2 1/2"	13'-9 1/2"	20'-4 1/2"	58"	25 1/2"	33 1/2"	51 1/2"	73"	20"	63"	67"	29"	45"	43"	23"	34 1/2"
C-114D-119-64	5'-4"	7'	9'-8 1/2"	14'-3 1/2"	11 1/2"	5'-3 1/2"	10'-4 1/2"	15'-4"	44"	25 1/2"	33 1/2"	39"	71 1/2"	11 1/2"	35 1/2"	51 1/2"	20"	30"	25"	16"	19 1/2"

NOTE: Do not use above dimensions for foundation. Request foundation plan.



LS PETROCHEM EQUIPMENT CORP

LS Petrochem Equipment Corporation, headquartered in Southern California, is the international division of the Lanzhou Petroleum & Chemical Machinery Works located in Lanzhou, China, known as LS for short.

For over fifty years LS has been manufacturing beam pumping units for oil production operations throughout the world. LS pumping units carry the API monogram (certificate No. 11E-0018) for design, and API Q1 and ISO 9001 certifications for quality.

The LS manufacturing complex consists of more than ten different manufacturing plants, offering a whole spectrum of solutions to the Oil & Gas Industry.

LS Petrochem Equipment products have been sold extensively around the world under the LS® brand name, as well as under OEM manufacturer brand names. During the late 1970's LS pumping units were marketed under the "NPS" and "HEC" brands, and throughout the 1980's and 1990's under the "DARCO-LS" brand.

Since 1998, the LS pumping unit has been marketed exclusively under the *LS Pumpjack* brand name.



ENHANCED GEOMETRY PUMPING UNIT

API Rear Mounted Geometry Class I Lever System with Phased Crank Counterbalance



Photo: RM-640D-305-166
Operating in Neuquen, Argentina

ENHANCED GEOMETRY PUMPING UNIT

General Specifications

API GEOMETRY CONSIDERATIONS

LS PUMPJACK's RM pumping unit offers certain benefits not typically found in any other Class I Conventional (C) pumping unit. Through its unique design geometry, the LS's Enhanced Geometry (RM) pumping unit exhibits higher mechanical efficiency and allows more crank rotation during the upstroke portion of the pumping cycle. This results in reduced energy requirements and added time for more complete pump fillage.

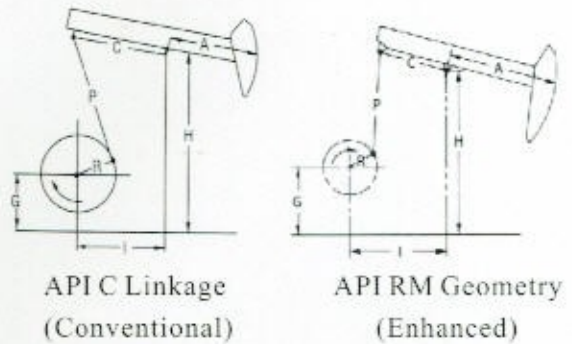

PHASED COUNTERBALANCE

The Enhanced (RM) Pumping Unit design also allows the counterbalance moment to be phased in a way that optimizes the lifting cycle, further decreasing gear reducer net torque and prime mover energy requirements.



TANGIBLE BENEFITS OVER CONVENTIONAL & FRONT MOUNTED UNITS

Compared to Conventional Class I geometries (C units), RM's upstroke dedicates a greater portions of its crank 360° rotation to the upstroke (as seen on Displacement and Velocity graphs below) enabling slower upstroke velocities for a better pump fillage.

Compared to Class III geometries (M units), RM's downstroke imposes lower accelerations to sucker rod strings, therefore preventing tension/compression transitions and so extending fatigue life of the pumping system.

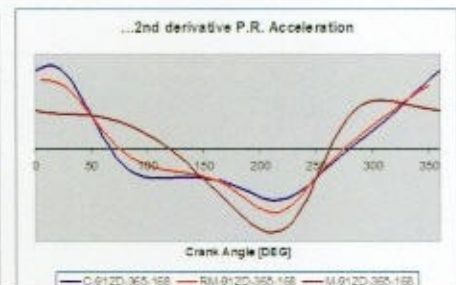
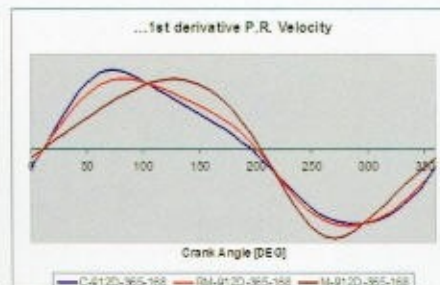
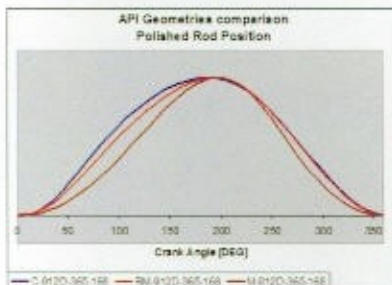

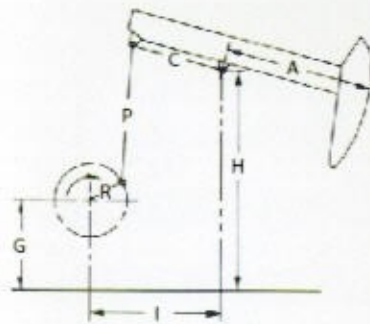

Enhanced Geometry
Pumping Unit API Linkage
Nomenclature

Unit Designation	Polished Rod Capacity, lbs.	Stroke Length in Inches
RM-1280D-427-192	42,700	192,158,126
RM-1280D-365-192	36,500	192,158,126
RM-1280D-427-168	42,700	168,139,112
RM-1280D-365-168	36,500	168,139,112
RM-912D-427-192	42,700	192,158,126
RM-912D-365-192	36,500	192,158,126
RM-912D-305-192	30,500	192,158,126
RM-912D-427-168	42,700	168,139,112
RM-912D-365-168	36,500	168,139,112
RM-912D-305-168	30,500	168,139,112
RM-912D-427-144	42,700	144,119,96
RM-912D-365-144	36,500	144,119,96
RM-912D-305-144	30,500	144,119,96
RM-640D-305-192	30,500	192,158,126
RM-640D-365-168	36,500	168,139,112
RM-640D-305-168	30,500	168,139,112
RM-640D-427-144	42,700	144,119,96
RM-640D-365-144	36,500	144,119,96
RM-640D-305-144	30,500	144,118,93
RM-640D-256-144	25,600	144,118,93
RM-640D-305-120	30,500	120,98,78
RM-640D-256-120	25,600	120,98,78
RM-456D-305-168	30,500	168,139,112
RM-456D-365-144	36,500	144,119,96
RM-456D-305-144	30,500	144,118,93
RM-456D-256-144	25,600	144,118,93
RM-456D-365-120	36,500	120,98,78
RM-456D-305-120	30,500	120,98,78
RM-456D-256-120	25,600	120,98,78
RM-320D-256-144	25,600	144,118,93
RM-320D-305-120	30,500	120,98,78
RM-320D-256-120	25,600	120,98,78
RM-320D-213-120	21,300	120,98,78
RM-320D-305-100	30,500	100,82,65
RM-320D-256-100	25,600	100,82,65
RM-320D-246-86	24,600	86,71,56
RM-228D-213-120	21,300	120,98,78
RM-228D-256-100	25,600	100,82,65
RM-228D-213-100	21,300	100,82,66
RM-228D-173-100	17,300	100,82,66
RM-228D-246-86	24,600	86,71,56
RM-228D-213-86	21,300	86,71,56
RM-228D-200-74	20,000	74,61,49
RM-228D-173-74	17,300	74,61,49

ENHANCED GEOMETRY PUMPING UNITS - API Linkage Table

UNIT MODEL	A	C	P	H	I	G	K	R1	R2	R3	SU [lbf]	T [Deg]	T.F. @ 90° / Max. Stroke
RM-1280D-427-192	231.89	118.11	171.26	273.23	161.42	111.81	228.28	45.08	38	30.91	-1450	-9	88.86
RM-1280D-365-192	231.89	118.11	171.26	273.23	161.42	111.81	228.28	45.08	38	30.91	-1380	-9	88.86
RM-1280D-427-168	198.03	114.17	161.42	263.39	151.58	111.81	214.36	45.08	38	30.91	-435	-9	78.78
RM-1280D-365-168	198.03	114.17	161.42	263.39	151.58	111.81	214.36	45.08	38	30.91	-360	-9	78.78
RM-912D-427-192	231.89	118.11	171.26	273.23	161.42	111.81	228.28	45.08	38	30.91	-1450	-9	88.86
RM-912D-365-192	231.89	118.11	171.26	273.23	161.42	111.81	228.28	45.08	38	30.91	-1380	-9	88.86
RM-912D-305-192	231.89	118.11	171.26	273.23	161.42	111.81	228.28	45.08	38	30.91	-1320	-9	88.86
RM-912D-427-168	198.03	114.17	161.42	263.39	151.58	111.81	214.36	45.08	38	30.91	-435	-9	78.78
RM-912D-365-168	198.03	114.17	161.42	263.39	151.58	111.81	214.36	45.08	38	30.91	-360	-9	78.78
RM-912D-305-168	198.03	114.17	161.42	263.39	151.58	111.81	214.36	45.08	38	30.91	-455	-9	78.78
RM-912D-427-144	169.49	114.17	161.42	263.39	151.58	111.81	214.36	45.08	38	30.91	75	-9	67.4
RM-912D-365-144	169.49	114.17	161.42	263.39	151.58	111.81	214.36	45.08	38	30.91	85	-9	67.4
RM-912D-305-144	169.49	114.17	161.42	263.39	151.58	111.81	214.36	45.08	38	30.91	350	-9	67.4
RM-640D-305-192	231.89	118.11	171.26	273.23	161.42	111.81	228.28	45.08	38	30.91	-1320	-9	88.86
RM-640D-365-168	198.03	114.17	161.42	263.39	151.58	111.81	214.36	45.08	38	30.91	-360	-9	78.78
RM-640D-305-168	198.03	114.17	161.42	263.39	151.58	111.81	214.36	45.08	38	30.91	-450	-9	78.78
RM-640D-427-144	169.49	114.17	161.42	263.39	151.58	111.81	214.36	45.08	38	30.91	75	-9	67.4
RM-640D-365-144	169.49	114.17	161.42	263.39	151.58	111.81	214.36	45.08	38	30.91	85	-9	67.4
RM-640D-305-144	173.23	102.36	141.73	231.5	135.04	96.46	190.97	39.37	32.87	26.38	350	-12	66.97
RM-640D-256-144	173.23	102.36	141.73	231.5	135.04	96.46	190.97	39.37	32.87	26.38	-150	-12	66.97
RM-640D-305-120	144.49	102.36	141.73	231.5	135.04	96.46	190.97	39.37	32.87	26.38	200	-12	55.87
RM-640D-256-120	144.49	102.36	141.73	231.5	135.04	96.46	190.97	39.37	32.87	26.38	126	-12	55.87
RM-456D-305-168	198.03	114.17	161.42	263.39	151.58	111.81	214.36	45.08	38	30.91	-455	-9	78.78
RM-456D-365-144	169.49	114.17	161.42	263.39	151.58	111.81	214.36	45.08	38	30.91	-85	-9	67.4
RM-456D-305-144	173.23	102.36	141.73	231.5	135.04	96.46	190.97	39.37	32.87	26.38	-245	-12	66.97
RM-456D-256-144	173.23	102.36	141.73	231.5	135.04	96.46	190.97	39.37	32.87	26.38	-230	-12	66.97
RM-456D-365-120	144.49	102.36	141.73	231.5	135.04	96.46	190.97	39.37	32.87	26.38	220	-12	55.87
RM-456D-305-120	144.49	102.36	141.73	231.5	135.04	96.46	190.97	39.37	32.87	26.38	200	-12	55.87
RM-456D-256-120	144.49	102.36	141.73	231.5	135.04	96.46	190.97	39.37	32.87	26.38	120	-12	55.87
RM-320D-256-144	173.23	102.36	141.73	231.5	135.04	96.46	190.97	39.37	32.87	26.38	-230	-12	66.97
RM-320D-305-120	144.49	102.36	141.73	231.5	135.04	96.46	190.97	39.37	32.87	26.38	200	-12	55.87
RM-320D-256-120	144.49	102.36	141.73	231.5	135.04	96.46	190.97	39.37	32.87	26.38	120	-12	55.87
RM-320D-213-120	144.49	102.36	141.73	231.5	135.04	96.46	190.97	39.37	32.87	26.38	115	-12	55.87
RM-320D-305-100	120.28	102.36	141.73	231.5	135.04	96.46	190.97	39.37	32.87	26.38	450	-12	46.5
RM-320D-256-100	120.28	102.36	141.73	231.5	135.04	96.46	190.97	39.37	32.87	26.38	220	-12	46.5
RM-320D-246-86	101.18	89.76	122.05	194.88	116.14	78.74	164.25	35.43	29.72	24.02	550	-14	40.2
RM-228D-213-120	144.49	102.36	141.73	231.5	135.04	96.46	190.97	39.37	32.87	26.38	50	-12	55.87
RM-228D-256-100	120.28	102.36	141.73	231.5	135.04	96.46	190.97	39.37	32.87	26.38	220	-12	46.5
RM-228D-213-100	117.72	89.76	122.05	194.88	116.14	78.74	164.25	35.43	29.72	24.02	210	-14	46.77
RM-228D-173-100	117.72	89.76	122.05	194.88	116.14	78.74	164.25	35.43	29.72	24.02	210	-14	46.77
RM-228D-246-86	101.18	89.76	122.05	194.88	116.14	78.74	164.25	35.43	29.72	24.02	550	-14	40.2
RM-228D-213-86	101.18	89.76	122.05	194.88	116.14	78.74	164.25	35.43	29.72	24.02	550	-14	40.2
RM-228D-200-74	87.21	89.76	122.05	194.88	116.14	78.74	164.25	35.43	29.72	24.02	750	-14	34.65
RM-228D-173-74	87.21	89.76	122.05	194.88	116.14	78.74	164.25	35.43	29.72	24.02	750	-14	34.65

ENHANCED GEOMETRY PUMPING UNITS Maximum ECB (Effective Counterbalance) Table

UNIT MODEL	Crank Name	ECB Cranks-only	ECB for LS Counterweight Sizes								
			No.1	No.2	No.3	No.4	No.5	No.6	No.7	No.8	No.9
RM-1280D-427-192	4354	4,624	23,278	19,724	17,947	16,701	14,848	13,037	11,153	9,595	8,194
RM-1280D-365-192	4354	4,624	23,278	19,724	17,947	16,701	14,848	13,037	11,153	9,595	8,194
RM-912D-365-192	4354	4,407	23,235	19,660	17,865	16,606	14,757	12,882	10,977	8,960	7,596
RM-912D-365-168	4354	6,240	27,284	23,275	21,271	19,865	17,775	15,732	13,607	11,849	10,268
RM-912D-305-168	4354	5,926	26,970	22,961	20,957	19,551	17,461	15,418	13,293	11,535	9,954
RM-912D-427-144	4045	5,907	-	24,109	22,027	20,519	18,305	16,085	13,822	11,412	9,771
RM-912D-365-144	4045	5,907	-	24,109	22,027	20,519	18,305	16,085	13,822	11,412	9,771
RM-640D-365-168	4354	5,940	26,984	22,975	20,971	19,565	17,475	15,432	13,307	11,549	9,968
RM-640D-305-168	4354	5,848	26,892	22,883	20,879	19,473	17,383	15,340	13,215	11,457	9,876
RM-640D-365-144	4045	5,907	-	24,109	22,027	20,519	18,305	16,085	13,822	11,412	9,771
RM-640D-305-144	4045	5,671	-	23,990	21,895	20,378	18,149	15,915	13,638	11,212	9,560
RM-640D-256-144	4045	5,431	-	23,702	21,613	20,099	17,876	15,648	13,376	10,957	9,311
RM-640D-305-120	3064	5,512	-	24,821	22,884	21,274	18,885	16,525	14,110	11,519	9,742
RM-456D-305-168	4354	5,560	26,821	22,784	20,758	19,336	17,248	15,131	12,980	10,702	9,161
RM-456D-305-144	3064	3,927	-	20,114	18,489	17,139	15,137	13,159	11,135	8,962	7,472
RM-456D-256-144	4045	5,431	-	23,702	21,613	20,099	17,876	15,648	13,376	10,957	9,311
RM-456D-365-120	3064	5,640	-	24,991	23,051	21,452	19,056	16,689	14,266	11,666	9,884
RM-456D-305-120	3064	5,532	-	24,892	22,951	21,352	18,955	16,585	14,162	11,560	9,777
RM-456D-256-120	3064	5,756	-	-	23,028	21,413	19,004	16,727	14,334	12,337	10,506
RM-320D-256-144	3064	3,824	-	20,019	18,393	17,042	15,040	13,060	11,036	8,862	7,371
RM-320D-256-120	3064	4,792	-	24,113	22,174	20,564	18,174	15,812	13,396	10,803	9,024
RM-320D-213-120	3064	4,801	-	23,842	21,930	20,343	17,968	15,661	13,280	10,724	8,971
RM-320D-305-100	3064	7,171	-	30,481	28,141	26,198	23,315	20,465	17,551	14,422	12,276
RM-320D-256-100	3064	7,167	-	30,463	28,125	26,183	23,301	20,453	17,540	14,414	12,270
RM-320D-246-86	1940	4,535	-	-	-	-	18,384	16,060	13,653	10,997	9,127
RM-228D-213-120	3064	4,466	-	24,260	22,080	20,433	18,013	15,622	13,176	10,551	8,750
RM-228D-256-100	3064	5,853	-	29,052	26,724	24,790	21,920	19,084	16,183	13,070	10,935
RM-228D-213-100	1940	3,646	-	-	-	-	15,512	13,520	11,457	9,182	7,582
RM-228D-173-100	1940	3,098	-	-	-	-	14,964	12,972	10,910	8,635	7,033
RM-228D-246-86	1940	4,500	-	-	-	-	18,294	15,980	13,581	10,937	9,075
RM-228D-213-86	1940	3,917	-	-	-	-	17,710	15,397	12,998	10,354	8,492
RM-228D-200-74	1940	5,178	-	-	-	-	21,189	18,503	15,719	12,649	10,488
RM-228D-173-74	1940	5,178	-	-	-	-	21,189	18,503	15,719	12,649	10,488

All Values Shown in Lbs. of Effective Counterbalance (ECB) at Polish Rod w/ Four Weights At Maximum Position on Crank, at Longest Stroke Length

*Maximum ECB achieved with Counterweight positioned not at end of crank arm. Contact LS Petrochem Equipment for counterweight maximum position on crank.

APPLICATION FORMULAS

Strokes Per Minute

$$SPM = \frac{RPM}{R} \times \frac{d}{D}$$

Example:

RPM = 1170 Revolutions per minute of prime mover
 R = 30.28 (912D Gear Reducer)
 d = 12" Pitch Diameter of Prime Mover Sheave
 D = 50" Pitch Diameter of Gear Reducer Sheave

$$SPM = \frac{1170}{30.28} \times \frac{12}{50} = 9.3$$

Prime Mover Sheave Diameter

$$d = \frac{SPM \times R \times D}{RPM}$$

SPM = 7 Strokes Per Minute
 R = 30.28 Ratio (912D Gear Reducer)
 D = 50" Pitch Diameter of Gear Reducer Sheave
 RPM = 1170 Revolutions Per Minute of Prime Mover

$$d = \frac{7 \times 30.28 \times 50}{1170} = 9 \text{ Inches}$$

Use nearest size available depending upon belt section and number of grooves in sheave.

Center Distance

$$CD = \sqrt{\left(S + \frac{T}{2}\right)^2 + (I - b)^2}$$

$$CD = \sqrt{\left(SS + \frac{TT}{2}\right)^2 + (II - b)^2}$$

Example:

Assume Hi-Prime Electric Motor
 Driven C228D-213-120 Conventional Unit
 SS = 27.5 (See General Dimensions)
 TT = 34.25 (See General Dimensions)
 II = 52.75 (See General Dimensions)
 b = 8 (Assume 25 HR Frame 324T Motor)

$$CD = \sqrt{\left(27.5 + \frac{34.25}{2}\right)^2 + (52.75 - 8)^2}$$

$$CD = 63.2 \text{ Inches}$$

Belt Length

$$PL = 2 CD + 1.57 (D + d) + \frac{(D - d)^2}{4 \times CD}$$

Example:

CD = 65.5 Inch Center Distance of Shafts
 D = 46 Inch Pitch Diameter of Gear Reducer Sheave
 d = 14 Inch Pitch Diameter of Prime Mover Sheave

$$PL = 2 \times 65.5 + 1.57 (46 + 14) + \frac{(46 - 14)^2}{4 \times 65.5}$$

PL = 229.1 Inches
 Use C225 Belts.

Horsepower of Prime Mover

For High Slip Electric Motors and Slow Speed Engines

$$HP = \frac{BPM \times \text{Depth}}{56000}$$

For Normal Slip Electric Motors and Multi-cylinder Engines

$$HP = \frac{BPM \times \text{Depth}}{45000}$$

Example:

BPD = 250 @ 100% pump efficiency
 Depth = 5000 Feet pump depth
 Assume High Slip (Nema D) Motor)

$$HP = \frac{250 \times 5000}{56000} = 22.32, \text{ use } 25 \text{ HP Motor}$$

Maximum Strokes Per Minute Based on the Free Fall Speed of the Rod

$$SPM = .7 \sqrt{\frac{60000}{L}}$$

Example:

Assume C-228-213-120 Unit

$$SPM = .7 \sqrt{\frac{60000}{L}} = 15.65 \text{ SPM Maximum}$$

SYMBOL DEFINITION

SPM = Strokes Per Minute
 RPM = Revolutions Per Minute of Prime Mover
 R = Gear Reducer Ratio
 D = Gear Reducer Sheave Pitch Diameter, Inches
 d = Prime Mover Sheave Pitch Diameter, Inches
 PL = Belt Pitch, Inches
 CD = Shaft Center Distance, Inches
 S = See General Dimensions
 T = See General Dimensions

I = See General Dimensions
 SS = See General Dimensions
 TT = See General Dimensions
 II = See General Dimensions
 b = Prime Mover Backing (Vertical Distance from Mounting Feet to Center to Shaft), Inc.
 HP = Horsepower
 BPD = Barrels Per Day at 100% Pump Efficiency
 Depth = Pump Setting, Feet
 L = Stroke Length, Inches



398 S. Lemon Creek Dr., Suite M
Walnut, CA 91789

11240 Brittmoore Park Dr.
Houston, TX 77041