

PUMPING UNIT

**GENERAL
CATALOG**

LUFKIN

OILFIELD PRODUCTS GROUP



CONTENTS

- 2 Introduction**
- 3 Conventional Crank
Balanced Pumping Units**
- 13 Mark II Unitorque
Pumping Units**
- 21 Air Balanced Pumping Units**
- 27 Reverse Mark Pumping Units**
- 35 Churchill® Brand Beam
Balanced Pumping Units**
- 41 Special Application
Pumping Units**
- 45 Gear Reducer and
Lubrication Data**
- 49 Optional Equipment
and Special Features**
- 55 Worldwide Parts and Service**
- 59 Artificial Lift Training**
- 60 Artificial Lift Nomenclature
and Application Formulas**
- 63 Ordering Instructions/Warranties**

LEADER IN THE FIELD

From the tall pines of East Texas to the sandy deserts of Saudi Arabia, the name Lufkin stands as mute testimony to one company's dedication to quality.

It all started from a small foundry and machine shop in the piney woods of East Texas that grew to become the world's foremost manufacturer of sucker rod pumping units. When the company was founded in 1902, it was known as Lufkin Foundry and Machine Company. By 1970 its diverse product line had long outgrown that name, and it was changed to Lufkin Industries, Inc. The Company's stock trades on the NASDAQ National Market System under the symbol LUFK.

Today, Lufkin Industries designs, manufactures and markets products and services to global energy, industrial and transportation markets through four divisions:



Oilfield Products Group. In addition to being the world's leading manufacturer and supplier of sucker rod pumping units, Lufkin Oilfield Services refurbishes and sells used pumping units and provides installation, field service, machine shop repair and new OEM parts for its' customers. All brands – Lufkin, Churchill, American, LeGrand, Bethlehem, National, etc. – are supported.

Additionally, Lufkin Automation is the industry leader in oil production automation and well optimization products and services (pump-off controllers, dynamometers, fluid level equipment, well analysis, design/analysis software, well design consulting and training). With the acquisition of Delta-X and Nabla and with thousands of controllers in service, Lufkin Automation continues the Lufkin tradition of helping producers lower their production costs and optimize well efficiency.

Power Transmission. This division's "high speed" products include turbo gears for power generation, process compressors, oil and gas transmission and a wide array of pumping applications. The "low speed" product family includes custom and standard drives for such industries as steel and aluminum mills, rubber mills, plastics mixing and extrusion, sugar mills, marine propulsion, cement mills and mining. Like the Oilfield Products Group, the Power Transmission division provides full service for its customers. From its unique gear manufacturing and machining operations, Lufkin repairs virtually any manufacturer's gears and provides 24-hour emergency service to ensure minimum downtime in a customer's operations.



Foundry Division. Lufkin's Foundry Division designs and manufactures medium to large, low to medium volume ductile and gray iron castings. On a daily basis, this division serves OEM's in various industries, including valves, machine tools, pump and compressors, as well as construction equipment and special machinery.

For current manufacturing accreditations
please refer to:

WWW.LUFKIN.COM/QUALITY



CONVENTIONAL CRANK BALANCED PUMPING UNITS



The Lufkin Conventional Crank Balanced Pumping Unit, widely known and accepted, is the old reliable “Work Horse” of the oil patch. This is the most universally adaptable unit in the Lufkin line. These units are simple to operate and require minimum maintenance.

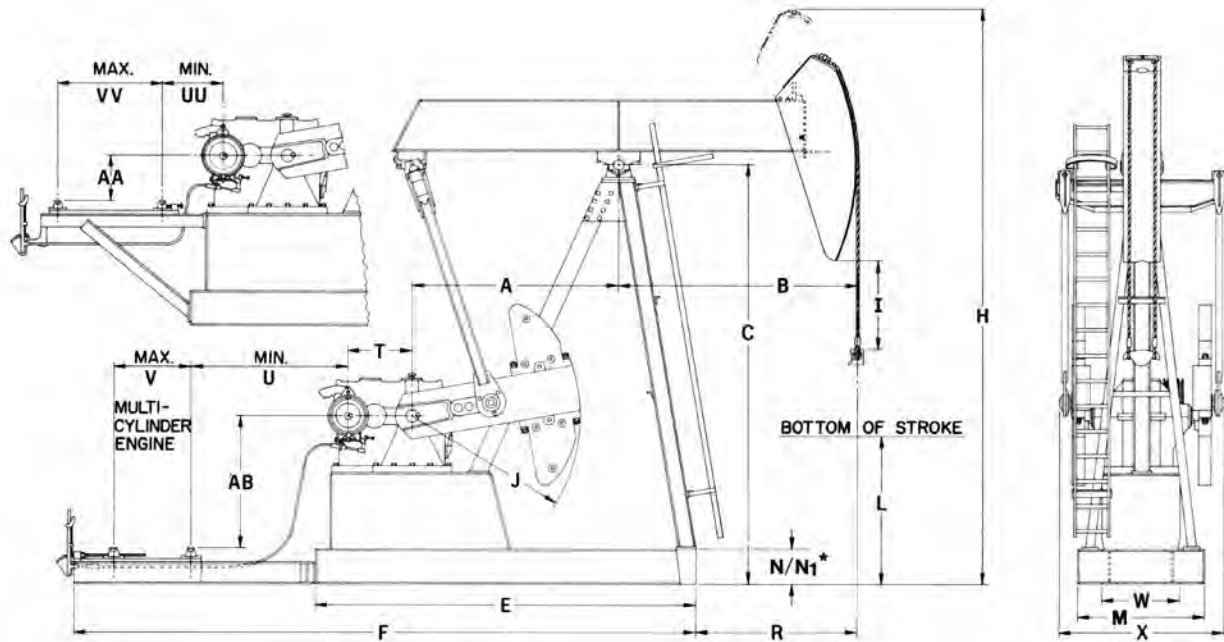

Dimensional Data (inches)

Unit Size*	A	B	C	E	F	H	I	J	L	M	N	N ₁ *	R	T	U	V	W	X	AA	AB	UU	VV
C-1824D-305-240	120.00	228.00	340.00	263.50	396.50	545.00	25.50	110.00	64.00	80.25	-	24.50	161.00	58.88	92.38	52.00	50.00	112.50	51.69	90.88	24.13	57.00
C-1824D-365-216	120.00	235.00	286.00	263.50	396.50	483.00	19.56	110.00	40.50	80.25	-	24.50	168.00	58.88	92.38	52.00	50.00	112.50	51.69	90.88	24.13	57.00
C-1824D-365-192	120.00	210.00	286.00	263.50	396.50	464.00	18.81	110.00	63.88	80.25	-	24.50	143.00	58.88	92.38	52.00	50.00	112.50	51.69	90.88	24.13	57.00
C-1280D-305-240	120.00	228.00	340.00	263.50	396.50	545.00	26.31	110.00	63.21	80.25	-	24.50	161.00	52.50	98.75	52.00	50.00	106.00	51.69	90.88	30.50	57.00
C-1280D-427-192	120.00	210.00	286.50	263.50	396.50	464.50	18.19	110.00	65.38	80.25	-	24.50	143.00	52.50	98.75	52.00	50.00	106.00	51.69	90.88	30.50	57.00
C-1280D-365-192	120.00	210.00	286.00	263.50	396.50	464.00	18.81	110.00	63.88	80.25	-	24.50	143.00	52.50	98.75	52.00	50.00	106.00	51.69	90.88	30.50	57.00
C-912D-305-240	120.00	228.00	340.00	247.50	396.50	545.00	25.50	110.00	64.00	80.25	-	24.50	161.56	48.50	91	52.00	50.00	98.50	51.69	90.88	19.25	57.00
C-912D-365-192	120.00	210.00	286.00	247.50	380.50	464.00	18.81	110.00	63.63	80.25	24.50	21.00	143.56	48.50	87.50	52.00	46.75	98.50	51.69	90.88	19.25	57.00
C-912D-305-192	120.00	210.00	286.00	247.50	380.50	464.00	18.81	110.00	63.63	80.25	24.50	21.00	143.56	48.50	87.50	52.00	46.75	98.50	51.69	90.88	19.25	57.00
C-912D-365-168	120.00	210.00	262.00	224.50	357.50	421.50	20.50	110.00	62.25	76.00	24.13	16.13	166.50	48.50	87.50	52.00	46.75	98.50	51.75	90.88	19.25	57.00
C-912D-305-168	120.00	210.00	262.00	224.50	357.50	421.50	20.50	110.00	62.00	76.00	24.13	16.13	166.50	48.50	87.50	52.00	46.75	98.50	51.75	90.88	19.25	57.00
C-912D-427-144	120.00	180.00	262.00	224.50	357.50	400.00	32.75	110.00	74.25	76.00	24.13	16.13	136.50	48.50	87.50	52.00	46.75	98.50	51.75	90.88	19.25	57.00
C-912D-365-144	120.00	180.00	262.00	224.50	357.50	400.00	32.75	110.00	74.25	76.00	24.13	16.13	136.50	48.50	87.50	52.00	46.75	98.50	51.75	90.88	19.25	57.00
C-640D-365-168	120.00	210.00	262.00	221.00	354.00	421.50	20.50	110.00	62.25	76.00	24.13	16.13	166.50	41.50	91.00	52.00	46.75	98.50	51.75	90.88	23.00	57.00
C-640D-305-168	120.00	210.00	262.00	221.00	354.00	421.50	20.50	110.00	62.25	76.00	24.13	16.13	166.50	41.50	91.00	52.00	46.75	98.50	51.75	90.88	23.00	57.00
C-640D-365-144	120.00	180.00	262.00	221.00	354.00	400.00	32.75	110.00	74.25	76.00	24.13	16.13	136.50	41.50	91.00	52.00	46.75	98.50	51.75	90.88	23.00	57.00
C-640D-305-144	120.00	180.00	260.00	220.75	353.75	398.00	32.75	110.00	72.50	76.00	21.13	16.13	136.88	41.50	91.13	52.00	46.75	98.50	51.75	90.88	23.00	57.00
C-640D-256-144	120.00	180.00	260.00	220.75	353.75	398.00	32.75	110.00	72.50	76.00	21.13	16.13	136.88	41.50	91.13	52.00	46.75	98.50	51.75	90.88	23.00	57.00
C-640D-365-120	120.00	152.00	260.00	220.75	353.75	379.00	54.50	110.00	75.50	76.00	21.13	16.13	108.88	41.50	91.13	52.00	46.75	98.50	51.75	90.88	23.00	57.00
C-640D-305-120	111.00	155.00	234.00	208.63	326.63	351.00	25.00	95.00	78.25	70.00	21.00	16.13	114.88	41.50	76.00	52.00	46.75	97.00	51.13	75.88	26.75	37.75
C-456D-305-168	120.00	210.00	262.00	221.00	354.00	421.50	20.50	110.00	62.25	76.00	24.13	16.13	166.50	38.38	94.13	52.00	46.75	98.50	51.75	90.88	26.13	57.00
C-456D-305-144	120.00	180.00	260.00	220.75	353.75	398.00	32.75	110.00	72.50	76.00	21.13	16.13	136.88	38.38	94.25	52.00	46.75	98.50	51.75	90.88	26.13	57.00
C-456D-256-144	120.00	180.00	260.00	220.75	353.75	398.00	32.75	110.00	72.50	76.00	21.13	16.13	136.88	38.38	94.25	52.00	46.75	98.50	51.75	90.88	26.13	57.00
C-456D-365-120	120.00	152.00	260.00	220.75	353.75	379.00	54.50	110.00	75.50	76.00	21.13	16.13	108.88	38.38	94.25	52.00	46.75	98.50	51.75	90.88	26.13	57.00
C-456D-305-120	111.00	155.00	234.00	208.63	326.63	351.00	25.00	95.00	78.25	70.00	21.00	16.13	114.88	38.38	79.13	52.00	46.75	97.00	51.13	75.88	29.88	37.75
C-456D-256-120	111.00	155.00	232.00	208.63	326.63	349.00	25.00	95.00	76.00	70.00	21.00	16.13	114.88	38.38	79.13	52.00	46.75	97.00	51.13	75.88	29.88	37.75
C-456D-213-120	111.00	155.00	232.00	208.63	326.63	349.00	25.00	95.00	76.00	70.00	21.00	16.13	114.88	38.38	79.13	52.00	46.75	97.00	51.13	75.88	29.88	37.75
C-456D-256-100	111.00	129.00	232.00	208.63	326.63	330.50	45.75	95.00	75.75	70.00	21.00	16.13	88.88	38.38	79.13	52.00	46.75	97.00	51.13	75.88	29.88	37.75
C-320D-256-144	120.00	180.00	260.00	215.25	353.75	398.00	32.75	110.00	72.50	76.00	21.13	16.13	136.88	34.00	98.63	52.00	43.00	87.50	53.625	93.00	31.00	48.25
C-320D-256-120	111.00	155.00	232.00	203.13	327.13	349.00	25.00	95.00	76.00	70.00	21.00	15.88	114.88	34.00	83.50	53.00	43.00	85.50	54.00	79.00	31.00	33.25
C-320D-213-120	111.00	155.00	232.00	203.13	327.13	349.00	25.00	95.00	76.00	70.00	21.00	15.88	114.88	34.00	83.50	53.00	43.00	85.50	54.00	79.00	31.00	33.25
C-320D-305-100	111.00	129.00	232.00	203.13	327.13	330.50	45.75	95.00	76.00	70.00	21.00	15.88	88.88	34.00	83.50	53.00	43.00	85.50	54.00	79.00	31.00	33.25

* Conventional Crank Balanced Units are available in either two-point foundation or standard base foundation designs. Two-point units are suitable for front and rear concrete block foundations, standard units must have a one-piece block foundation supporting the entire steel base. Dimension "N" is for two-point units and dimension "N₁" is for standard units.

NOTE: Do not use the above dimensions for foundation. Request a foundation plan. Popular API models shown, other models available on request.

CONVENTIONAL CRANK BALANCED PUMPING UNITS



Dimensional Data (inches)

Unit Size	A	B	C	E	F	H	I	J	L	M	N	N ₁	R	T	U	V	W	X	AA	AB	UU	VV
C-320D-256-100	111.00	129.00	232.00	203.13	327.13	330.50	45.75	95.00	76.00	70.00	21.00	15.88	88.88	34.00	83.50	53.00	43.00	85.50	54.00	79.00	31.00	33.25
C-320D-246-86	111.00	111.00	232.00	203.13	327.13	317.50	59.75	95.00	75.75	70.00	21.00	15.88	70.88	34.00	83.50	53.00	43.00	85.50	54.00	79.00	31.00	33.25
C-320D-213-86	96.00	111.00	196.13	183.50	290.50	282.00	23.75	78.00	75.00	57.75	16.13	15.88	75.50	34.00	66.50	53.00	43.00	85.50	37.13	62.13	30.88	33.25
C-320D-246-74	96.00	96.00	196.13	183.50	290.50	271.00	35.50	78.00	77.75	57.75	16.13	15.88	60.50	34.00	66.50	53.00	43.00	85.50	37.13	62.13	30.88	33.25
C-228D-213-120	111.00	155.00	232.00	196.13	326.63	349.00	25.13	95.00	76.00	70.00	21.00	15.88	114.88	30.00	87.00	53.00	37.00	78.50	54.00	79.00	28.00	33.25
C-228D-213-100	96.00	129.00	196.13	176.50	290.00	295.00	21.75	78.00	63.00	59.75	16.13	15.88	93.50	30.00	70.00	53.00	37.00	78.50	37.13	62.13	27.88	33.25
C-228D-173-100	96.00	129.00	196.13	176.50	290.00	295.00	21.75	78.00	63.00	59.75	16.13	15.88	93.50	30.00	70.00	53.00	37.00	78.50	37.13	62.13	27.88	33.25
C-228D-246-86	111.00	111.00	232.00	196.13	326.63	317.50	59.75	95.00	75.75	70.00	21.00	15.88	70.88	30.00	87.00	53.00	37.00	78.50	54.00	79.00	28.00	33.25
C-228D-213-86	96.00	111.00	196.13	176.50	290.00	282.00	23.75	78.00	75.00	59.75	16.13	15.88	75.50	30.00	70.00	53.00	37.00	78.50	37.13	62.13	27.88	33.25
C-228D-200-74	96.00	96.00	196.13	176.50	290.00	271.00	35.63	78.00	77.25	59.75	16.13	15.88	60.50	30.00	70.00	53.00	37.00	78.50	37.13	62.13	27.88	33.25
C-228D-173-74	84.00	96.00	168.25	160.00	273.50	243.00	16.75	68.00	68.75	51.75	15.88	12.25	65.00	30.00	70.00	53.00	37.00	78.50	27.25	52.25	27.88	33.25
C-160D-173-100	96.00	129.00	195.13	172.00	288.00	295.00	21.50	78.00	62.75	57.75	15.88	15.88	93.50	26.00	74.50	50.00	32.00	70.50	37.13	62.88	26.63	34.75
C-160D-173-86	96.00	111.00	195.13	172.00	288.00	282.00	23.75	78.00	74.88	57.75	15.88	15.88	75.50	26.00	74.50	50.00	32.00	70.50	37.13	62.88	26.63	34.75
C-160D-200-74	96.00	96.00	195.13	172.00	288.00	271.00	35.25	78.00	77.25	57.75	15.88	15.88	60.50	26.00	74.50	50.00	32.00	70.50	37.13	62.88	26.63	34.75
C-160D-173-74	84.00	96.00	168.25	155.50	260.50	243.00	16.75	68.00	68.75	51.75	15.88	15.88	65.00	26.00	63.50	50.00	32.00	70.50	23.63	53.25	26.63	34.75
C-160D-143-74	84.00	96.00	166.00	155.50	260.50	241.00	16.75	68.00	66.00	51.75	15.88	15.88	65.00	26.00	63.50	50.00	32.00	70.50	23.63	53.25	26.63	34.75
C-160D-173-64	84.00	84.00	166.00	155.50	260.50	232.50	26.00	68.00	67.00	51.75	15.88	15.88	53.00	26.00	63.50	50.00	32.00	69.75	23.63	53.25	26.63	34.75
C-160D-143-64	72.00	84.00	146.50	133.75	227.75	210.00	18.00	56.00	53.75	50.75	12.25	12.25	62.75	26.00	52.50	50.00	32.00	69.75	28.75	41.25	17.13	30.25
C-114D-119-86	84.00	111.00	166.00	150.00	266.00	252.00	14.75	68.00	54.50	51.75	15.88	12.25	80.00	24.00	71.00	50.00	25.00	66.75	27.50	53.25	23.13	34.75
C-114D-143-74	84.00	96.00	166.00	150.00	266.00	241.00	16.75	68.00	66.50	51.75	15.88	12.25	65.00	24.00	71.00	50.00	25.00	66.75	27.50	53.25	23.13	34.75
C-114D-173-64	84.00	84.00	166.00	150.00	266.00	232.50	26.13	68.00	67.00	51.75	15.88	12.25	53.00	24.00	71.00	50.00	25.00	66.75	27.50	53.25	23.13	34.75
C-114D-143-64	72.00	84.00	146.50	128.25	226.25	210.00	18.13	56.00	53.75	50.75	12.25	12.25	62.75	24.00	53.00	50.00	25.00	66.75	28.75	41.25	13.63	30.25
C-114D-173-54	72.00	72.00	146.50	128.25	226.25	201.00	19.38	56.00	62.25	50.75	12.25	12.25	50.75	24.00	53.00	50.00	25.00	66.75	28.75	41.25	13.63	30.25
C-114D-133-54	64.00	72.00	116.00	119.88	213.88	183.00	13.50	50.00	49.88	47.00	-	10.13	51.13	24.00	49.00	50.00	25.00	67.25	22.63	35.13	13.50	30.25
C-80D-119-64	64.00	84.00	116.00	119.88	213.88	191.50	13.25	50.00	40.38	47.00	-	10.13	63.13	24.00	49.00	50.00	25.00	67.25	22.63	35.13	13.50	30.25
C-80D-133-54	64.00	72.00	116.00	119.88	213.88	183.00	13.50	50.00	49.88	47.00	-	10.13	51.13	24.00	49.00	50.00	25.00	67.25	22.63	35.13	13.50	30.25
C-80D-119-54	64.00	72.00	116.00	119.88	213.88	183.00	13.50	50.00	49.88	47.00	-	10.13	51.13	24.00	49.00	50.00	25.00	67.25	22.63	35.13	13.50	30.25
C-80D-133-48	64.00	64.00	116.00	119.88	213.88	177.00	14.63	50.00	54.88	47.00	-	10.13	43.13	24.00	49.00	50.00	25.00	67.25	22.63	35.13	13.50	30.25
C-80D-109-48	56.00	64.00	105.00	111.88	200.38	166.25	14.63	46.00	44.00	40.75	-	10.13	43.13	24.00	45.50	50.00	25.00	65.25	18.63	31.13	13.50	30.25
C-57D-76-54	56.00	72.00	105.00	111.88	200.38	172.00	13.63	46.00	38.88	40.75	-	10.13	51.13	20.00	47.50	50.00	25.00	58.25	18.63	31.13	17.50	30.25
C-57D-109-48	56.00	64.00	105.00	111.88	200.38	166.25	16.00	46.00	42.75	40.75	-	10.13	43.13	20.00	47.50	50.00	25.00	58.25	18.63	31.13	17.50	30.25
C-57D-95-48	56.00	64.00	105.00	111.88	200.38	166.25	16.00	46.00	42.75	40.75	-	10.13	43.13	20.00	47.50	50.00	25.00	58.25	18.63	31.13	17.50	30.25
C-57D-89-42	48.00	56.00	98.50	98.00	186.50	152.00	16.38	44.00	42.00	38.50	-	8.13	41.00	20.00	47.50	50.00	25.00	58.00	16.63	29.13	17.50	30.25
C-57D-76-42	48.00	56.00	98.50	98.00	186.50	152.00	16.38	44.00	42.00	38.50	-	8.13	41.00	20.00	47.50	50.00	25.00	58.00	16.63	29.13	17.50	30.25

* Conventional Crank Balanced Units are available in either two-point foundation or standard base foundation designs. Two-point units are suitable for front and rear concrete block foundations, standard units must have a one-piece block foundation supporting the entire steel base. Dimension "N" is for two-point units and dimension "N1" is for standard units.

NOTE: Do not use the above dimensions for foundation. Request a foundation plan. Popular API models shown, other models available on request.
For smaller units see Churchill Beam Balanced Units, page 35.

Two-Point Foundation

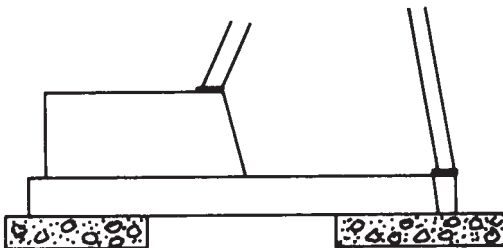

Standard Foundation

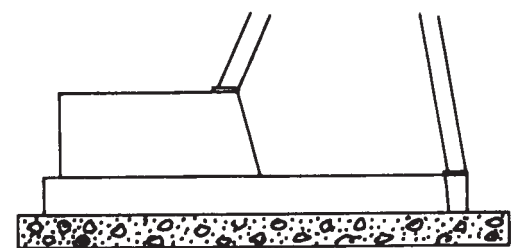

The first "enclosed, geared" pumping unit was built by Lufkin for Humble Oil in 1923. Since then, over 250,000 Lufkin units have been manufactured.

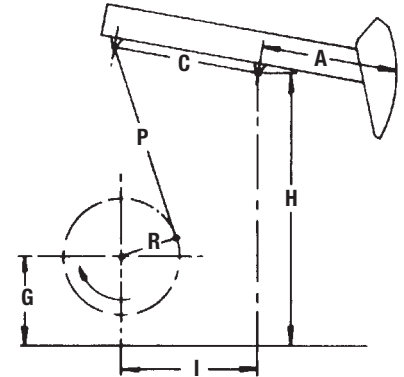

API Geometry Dimensions (inches)

Unit Size	A	C	I	P	H	G	R1, R2, R3, R4	S.U.*	T.F. @ 90°/Stroke Length
C-1824D-305-240	228	120.03	120	226.75	340.00	111.00	60, 53, 46, 39	-2740	111.78/240
C-1280D-305-240	228	120.03	120	226.80	340.00	111.00	60, 53, 46, 39	-2855	111.78/240
C-912D-305-240	228	120.03	120	226.75	340.00	111.00	60, 53, 46, 39	-2740	111.78/240
C-1824D-365-216	235	120.03	120	172.50	286.00	111.00	53, 46, 39, 32	-2030	101.31/216
C-1280D-427-192	210	120.03	120	172.50	286.50	111.00	53, 46, 39, 32	-995	90.43/192
C-1824D-365-192	210	120.03	120	172.50	286.00	111.00	53, 46, 39, 32	-1985	90.51/192
C-1280D-365-192	210	120.03	120	172.50	286.00	111.00	53, 46, 39, 32	-1800	90.51/192
C-912D-365-192	210	120.03	120	172.50	286.00	111.00	53, 46, 39, 32	-1800	90.51/192
C-912D-305-192	210	120.03	120	172.50	286.00	111.00	53, 46, 39, 32	-1800	90.51/192
C-912D-365-168	210	120.03	120	148.50	262.00	111.00	47, 41, 35	-1500	80.29/168
C-912D-305-168	210	120.03	120	148.50	262.00	111.00	47, 41, 35	-1500	80.29/168
C-640D-365-168	210	120.03	120	148.50	262.00	111.00	47, 41, 35	-1500	80.29/168
C-640D-305-168	210	120.03	120	148.50	262.00	111.00	47, 41, 35	-1500	80.29/168
C-456D-305-168	210	120.03	120	148.50	262.00	111.00	47, 41, 35	-1500	80.29/168
C-912D-427-144	180	120.03	120	148.50	262.00	111.00	47, 41, 35	-650	68.82/144
C-912D-365-144	180	120.03	120	148.50	262.00	111.00	47, 41, 35	-650	68.82/144
C-640D-365-144	180	120.03	120	148.50	262.00	111.00	47, 41, 35	-650	68.82/144
C-640D-305-144	180	120.08	120	144.50	260.00	111.00	47, 41, 35	-520	68.45/144
C-456D-305-144	180	120.08	120	144.50	260.00	111.00	47, 41, 35	-520	68.45/144
C-640D-256-144	180	120.08	120	144.50	260.00	111.00	47, 41, 35	-400	68.45/144
C-456D-256-144	180	120.08	120	144.50	260.00	111.00	47, 41, 35	-400	68.45/144
C-320D-256-144	180	120.08	120	144.50	260.00	111.00	47, 41, 35	-400	68.45/144
C-640D-365-120	152	120.03	120	148.50	262.00	111.00	47, 41, 35	570	58.12/120
C-456D-365-120	152	120.03	120	148.50	262.00	111.00	47, 41, 35	570	58.12/120
C-640D-305-120	155	111.09	111	133.50	234.00	96.00	42, 36, 30	-120	57.02/120
C-456D-305-120	155	111.09	111	133.50	234.00	96.00	42, 36, 30	-120	57.02/120
C-456D-256-120	155	111.07	111	132.00	232.00	96.00	42, 36, 30	55	57.05/120
C-320D-256-120	155	111.07	111	132.00	232.00	96.00	42, 36, 30	55	57.05/120
C-456D-213-120	155	111.07	111	132.00	232.00	96.00	42, 36, 30	0	57.05/120
C-320D-213-120	155	111.07	111	132.00	232.00	96.00	42, 36, 30	0	57.05/120
C-228D-213-120	155	111.07	111	132.00	232.00	96.00	42, 36, 30	0	57.05/120
C-456D-256-100	129	111.07	111	132.00	232.00	96.00	42, 36, 30	550	47.48/100
C-320D-256-100	129	111.07	111	132.00	232.00	96.00	42, 36, 30	550	47.48/100
C-320D-305-100	129	111.07	111	132.00	232.00	96.00	42, 36, 30	550	47.48/100
C-228D-213-100	129	96.08	96	113.00	196.13	79.13	37, 32, 27	0	48.21/100
C-228D-173-100	129	96.05	96	114.00	196.13	79.13	37, 32, 27	0	48.36/100
C-160D-173-100	129	96.05	96	114.00	195.88	78.88	37, 32, 27	0	48.36/100
C-320D-246-86	111	111.04	111	133.00	232.00	96.00	42, 36, 30	800	40.96/86
C-228D-246-86	111	111.04	111	133.00	232.00	96.00	42, 36, 30	800	40.96/86
C-320D-213-86	111	96.05	96	114.00	196.13	79.13	37, 32, 27	450	41.61/86
C-228D-213-86	111	96.05	96	114.00	196.13	79.13	37, 32, 27	450	41.61/86
C-160D-173-86	111	96.05	96	114.00	195.88	78.88	37, 32, 27	450	41.61/86
C-114D-119-86	111	84.05	84	93.75	166.00	69.25	32, 27, 22	115	40.98/86

* Structural Unbalance in pounds.

CONVENTIONAL CRANK BALANCED PUMPING UNITS

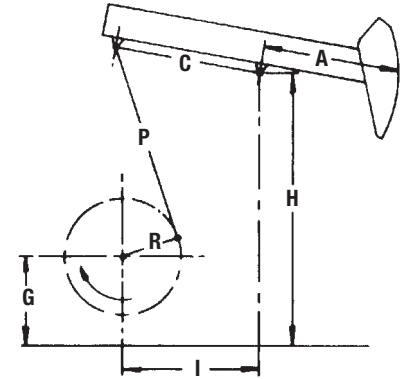

API Geometry Dimensions (inches)

Unit Size	A	C	I	P	H	G	R1, R2, R3, R4	S.U.*	T.F. @ 90°/Stroke Length
C-320D-246-74	96	96.05	96	114.00	196.13	79.13	37, 32, 27	800	35.99/74
C-228D-200-74	96	96.05	96	114.00	196.13	79.13	37, 32, 27	800	35.99/74
C-160D-200-74	96	96.05	96	114.00	195.88	78.88	37, 32, 27	800	35.99/74
C-228D-173-74	96	84.05	84	96.00	168.25	69.25	32, 27, 22	450	35.49/74
C-160D-173-74	96	84.05	84	96.00	168.25	69.25	32, 27, 22	450	35.49/74
C-160D-143-74	96	84.05	84	93.75	166.00	69.25	32, 27, 22	300	35.45/74
C-114D-143-74	96	84.05	84	93.75	166.00	69.25	32, 27, 22	300	35.45/74
C-160D-173-64	84	84.05	84	93.75	166.00	69.25	32, 27, 22	550	31.02/64
C-114D-173-64	84	84.05	84	93.75	166.00	69.25	32, 27, 22	550	31.02/64
C-160D-143-64	84	72.06	72	84.00	144.25	57.25	27, 22, 17	360	30.59/64
C-114D-143-64	84	72.06	72	84.00	144.25	57.25	27, 22, 17	360	30.59/64
C-80D-119-64	84	64.00	64	74.50	126.13	51.13	24, 20, 16	0	30.85/64
C-114D-173-54	72	72.06	72	84.00	144.25	57.25	27, 22, 17	500	26.22/54
C-114D-133-54	72	64.00	64	74.50	126.13	51.13	24, 20, 16	330	26.45/54
C-80D-133-54	72	64.00	64	74.50	126.13	51.13	24, 20, 16	330	26.45/54
C-80D-119-54	72	64.00	64	74.50	126.13	51.13	24, 20, 16	300	26.45/54
C-57D-76-54	72	56.05	56	65.63	115.13	47.13	21, 16, 11	0	26.22/54
C-80D-133-48	64	64.00	64	74.50	126.13	51.13	24, 20, 16	440	23.51/48
C-80D-109-48	64	56.05	56	65.63	115.13	47.13	21, 16, 11	320	23.30/48
C-57D-109-48	64	56.05	56	65.63	115.13	47.13	21, 16, 11	320	23.30/48
C-57D-95-48	64	56.05	56	65.63	115.13	47.13	21, 16, 11	320	23.30/48
C-57D-89-42	56	48.17	48	57.50	106.63	45.13	18, 14, 10	150	20.21/42
C-57D-76-42	56	48.17	48	57.50	106.63	45.13	18, 14, 10	150	20.21/42

* Structural Unbalance in pounds.

Structural Data

Unit Size	Polished Rod Capacity (lbs.)	Stroke Lengths (inches)	Walking Beam	Wireline Hanger (inches)	Cranks	Crank Pin Bearing	Equalizer Bearing	Center Bearing
C-1824D-305-240	30,500	240, 209, 179, 151	W33 x 241	1-3/8 x 16 CTRS.	120110CA	1SE	ORA	OTGB
C-1280D-305-240	30,500	240, 209, 179, 151	W33 x 241	1-3/8 x 16 CTRS.	120110CA	1SE	ORA	OTGB
C-912D-305-240	30,500	240, 209, 179, 151	W33 X 241	1-3/8 x 16 CTRS.	120110CA	1SE	ORA	OTGB
C-1824D-365-216	36,500	216, 185, 155, 126	W33 x 241	1-3/8 x 16 CTRS.	106110CA	OS	OOR	OOTG
C-1280D-427-192	42,700	192, 166, 139, 113	W36 x 247	1-3/8 x 16 CTRS.	106110CA	OS	OOR	OOTG
C-1824D-365-192	36,500	192, 165, 139, 113	W33 x 221	1-3/8 x 16 CTRS.	106110CA	1SE	ORA	OTGB
C-1280D-365-192	36,500	192, 165, 139, 113	W33 x 221	1-3/8 x 16 CTRS.	106110CA	1SE	ORA	OTGB
C-912D-365-192	36,500	192, 165, 139, 113	W33 x 221	1-3/8 x 16 CTRS.	106110CA	1SE	ORA	OTGB
C-912D-305-192	30,500	192, 165, 139, 113	W33 x 201	1-1/4 x 16 CTRS.	106110CA	1SE	ORA	OTGB
C-912D-365-168	36,500	168, 145, 124	W33 x 221	1-3/8 x 16 CTRS.	94110CA	1SE	ORA	OTGB
C-640D-365-168	36,500	168, 145, 124	W33 x 221	1-3/8 x 16 CTRS.	94110CA	1SE	ORA	OTGB
C-912D-305-168	30,500	168, 145, 124	W33 x 201	1-1/4 x 16 CTRS.	94110CA	1SE	ORA	OTGB
C-640D-305-168	30,500	168, 145, 124	W33 x 201	1-1/4 x 16 CTRS.	94110CA	1SE	ORA	OTGB
C-456D-305-168	30,500	168, 145, 124	W33 x 201	1-1/4 x 16 CTRS.	94110CA	1SE	ORA	OTGB
C-912D-427-144	42,700	144, 124, 106	W33 x 221	1-3/8 x 16 CTRS.	94110CA	1SE	ORA	OTGB
C-912D-365-144	36,500	144, 124, 106	W33 x 201	1-3/8 x 16 CTRS.	94110CA	1SE	ORA	OTGB
C-640D-365-144	36,500	144, 124, 106	W33 x 201	1-3/8 x 16 CTRS.	94110CA	1SE	ORA	OTGB
C-640D-305-144	30,500	144, 124, 106	W30 x 173	1-1/4 x 16 CTRS.	94110CA	1SE	ORA	1TGC
C-456D-305-144	30,500	144, 124, 106	W30 x 173	1-1/4 x 16 CTRS.	94110CA	1SE	ORA	1TGC
C-640D-256-144	25,600	144, 124, 106	W30 x 173	1-1/4 x 16 CTRS.	94110CA	1SE	ORA	1TGC
C-456D-256-144	25,600	144, 124, 106	W30 x 173	1-1/4 x 16 CTRS.	94110CA	1SE	ORA	1TGC
C-320D-256-144	25,600	144, 124, 106	W30 x 173	1-1/4 x 16 CTRS.	94110CA	1SE	ORA	1TGC
C-640D-365-120	36,500	120, 105, 90	W30 x 173	1-3/8 x 12 CTRS.	94110CA	1SE	ORA	OTGB
C-456D-365-120	36,500	120, 105, 90	W30 x 173	1-3/8 x 12 CTRS.	94110CA	1SE	ORA	OTGB
C-640D-305-120	30,500	120, 102, 85	W27 x 161	1-1/4 x 12 CTRS.	8495CA	2SE	ORA	1TGC
C-456D-305-120	30,500	120, 102, 85	W27 x 161	1-1/4 x 12 CTRS.	8495CA	2SE	ORA	1TGC
C-456D-256-120	25,600	120, 102, 85	W27 x 146	1-1/8 x 12 CTRS.	8495CA	2SE	1RA	2TGC
C-320D-256-120	25,600	120, 102, 85	W27 x 146	1-1/8 x 12 CTRS.	8495CA	2SE	1RA	2TGC
C-456D-213-120	21,300	120, 102, 85	W27 x 146	1-1/8 x 12 CTRS.	8495CA	2SE	1RA	2TGC
C-320D-213-120	21,300	120, 102, 85	W27 x 146	1-1/8 x 12 CTRS.	8495CA	2SE	1RA	2TGC
C-228D-213-120	21,300	120, 102, 85	W27 x 146	1-1/8 x 12 CTRS.	8495CA	2SE	1RA	2TGC
C-320D-305-100	30,500	100, 85, 70	W27 x 146	1-1/4 x 12 CTRS.	8495CA	2SE	1RA	2TGC
C-456D-256-100	25,600	100, 85, 70	W27 x 146	1-1/8 x 12 CTRS.	8495CA	2SE	1RA	2TGC
C-320D-256-100	25,600	100, 85, 70	W27 x 146	1-1/8 x 12 CTRS.	8495CA	2SE	1RA	2TGC
C-228D-213-100	21,300	100, 86, 73	W24 x 117	1-1/8 x 12 CTRS.	7478CA	2SE	1RA	2TGC
C-228D-173-100	17,300	100, 86, 73	W24 x 104	1-1/8 x 12 CTRS.	7478CA	3SF	2RB	2TGC
C-160D-173-100	17,300	100, 86, 73	W24 x 104	1-1/8 x 12 CTRS.	7478CA	3SF	2RB	2TGC
C-320D-246-86	24,600	86, 74, 61	W24 x 117	1-1/8 x 12 CTRS.	8495CA	3SF	2RB	2TGC
C-228D-246-86	24,600	86, 74, 61	W24 x 117	1-1/8 x 12 CTRS.	8495CA	3SF	2RB	2TGC
C-320D-213-86	21,300	86, 74, 62	W24 x 104	1-1/8 x 12 CTRS.	7478CA	3SF	2RB	2TGC
C-228D-213-86	21,300	86, 74, 62	W24 x 104	1-1/8 x 12 CTRS.	7478CA	3SF	2RB	2TGC
C-160D-173-86	17,300	86, 74, 62	W24 x 104	1-1/8 x 12 CTRS.	7478CA	3SF	2RB	2TGC
C-114D-119-86	11,900	86, 72, 59	W24 x 84	1-1/8 x 12 CTRS.	6468CA	4SF	3RA	4TG

CONVENTIONAL CRANK BALANCED PUMPING UNITS

Structural Data

Unit Size	Polished Rod Capacity (lbs.)	Stroke Lengths (inches)	Walking Beam	Wireline Hanger (inches)	Cranks	Crank Pin Bearing	Equalizer Bearing	Center Bearing
C-320D-246-74	24,600	74, 64, 54	W24 x 104	1-1/8 x 9 CTRS.	7478CA	3SF	2RB	2TGC
C-228D-200-74	20,000	74, 64, 54	W24 x 94	1 x 9 CTRS.	7478CA	3SF	2RB	2TGC
C-160D-200-74	20,000	74, 64, 54	W24 x 94	1 x 9 CTRS.	7478CA	3SF	2RB	2TGC
C-228D-173-74	17,300	74, 62, 51	W24 x 84	1 x 9 CTRS.	6468CA	3SF	2RB	2TGC
C-160D-173-74	17,300	74, 62, 51	W24 x 84	1 x 9 CTRS.	6468CA	3SF	2RB	2TGC
C-160D-143-74	14,300	74, 62, 51	W24 x 84	1 x 9 CTRS.	6468CA	4SF	3RA	4TG
C-114D-143-74	14,300	74, 62, 51	W24 x 84	1 x 9 CTRS.	6468CA	4SF	3RA	4TG
C-160D-173-64	17,300	64, 54, 44	W24 x 84	1 x 9 CTRS.	6468CA	4SF	3RA	4TG
C-114D-173-64	17,300	64, 54, 44	W24 x 84	1 x 9 CTRS.	6468CA	4SF	3RA	4TG
C-160D-143-64	14,300	64, 52, 40	W18 x 71	1 x 9 CTRS.	5456CA	4SF	3RA	4TG
C-114D-143-64	14,300	64, 52, 40	W18 x 71	1 x 9 CTRS.	5456CA	4SF	3RA	4TG
C-80D-119-64	11,900	64, 53, 42	W18 x 60	1 x 9 CTRS.	4850BA	5SA	4RA	4TG
C-114D-173-54	17,300	54, 44, 34	W18 x 71	1 x 9 CTRS.	5456CA	4SF	3RA	4TG
C-114D-133-54	13,300	54, 45, 36	W18 x 60	7/8 x 9 CTRS.	4850BA	5SA	4RA	4TG
C-80D-133-54	13,300	54, 45, 36	W18 x 60	7/8 x 9 CTRS.	4850BA	5SA	4RA	4TG
C-80D-119-54	11,900	54, 45, 36	W18 x 60	7/8 x 9 CTRS.	4850BA	5SA	4RA	4TG
C-57D-76-54	7,600	54, 41, 28	W16 x 36	3/4 x 9 CTRS.	4246BA	5SA	5R	5C
C-80D-133-48	13,300	48, 40, 32	W16 x 57	7/8 x 9 CTRS.	4850BA	5SA	4RA	4TG
C-80D-109-48	10,900	48, 37, 25	W16 x 45	7/8 x 9 CTRS.	4246BA	5SA	5R	5C
C-57D-109-48	10,900	48, 37, 25	W16 x 45	7/8 x 9 CTRS.	4246BA	5SA	5R	5C
C-57D-95-48	9,500	48, 37, 25	W16 x 45	7/8 x 9 CTRS.	4246BA	5SA	5R	5C
C-57D-89-42	8,900	42, 33, 23	W16 x 36	3/4 x 6-1/2 CTRS.	3644BA	6	7R	6CA
C-57D-76-42	7,600	42, 33, 23	W16 x 36	3/4 x 6-1/2 CTRS.	3644BA	6	7R	6CA

Counterbalance Data (shown in lbs., effective at polished rod with weights at maximum position, including structural unbalance.)

Unit Size	C-1824D-305-240	C1824D-365-216	C-1824D-365-192	C-1280D-305-240	C-1280D-427-192	C-1280D-365-192	C-912D-305-168	C-912D-305-168	C-640D-365-168	C-640D-305-168	C-456D-305-168
	C-912D-305-240					C-912D-305-192					
Maximum Stroke	240"	216"	192"	240"	192"	192"	168"				
Structural Unbalance	-2,740 lbs.	-2,030 lbs.	-1,985 lbs.	-2,855 lbs.	-1,149 lbs.	-1,800 lbs.	-1,500 lbs.				
Cranks	120110CA	106110CA	106110CA	120110CA	106110CA	106110CA	94110CA				
C'Bal., Cranks Only	1,470	2,615	3,215	1,356	4,060	3,400	4,360				
4 No. OOROL Counterweights	15,035	17,585	19,970	14,920	20,829	20,155	-				
4 No. OOSL Aux. Weights	19,040	22,000	24,915	18,925	25,716	25,100	-				
8 No. OOSL Aux. Weights	23,040	26,415	29,860	22,925	30,724	30,045	-				
4 No. OORO Counterweights	12,255	14,515	16,535	12,140	17,395	16,720	19,380				
4 No. OOS Aux. Weights	15,510	18,105	20,555	15,395	21,420	20,740	23,910				
8 No. OOS Aux. Weights	18,765	21,695	24,575	18,650	25,445	24,760	28,440				
4 No. ORO Counterweights	10,880	12,995	14,835	10,765	15,690	15,020	17,455				
4 No. OS Aux. Weights	14,005	16,440	18,695	13,885	19,550	18,880	21,805				
8 No. OS Aux. Weights	17,130	19,885	22,555	17,010	23,410	22,740	26,150				
4 No. OARO Counterweights	9,430	11,400	13,045	9,315	13,900	13,230	15,440				
4 No. OAS Aux. Weights	11,895	14,120	16,090	11,780	16,945	16,275	18,870				
8 No. OAS Aux. Weights	14,360	16,840	19,135	14,245	19,990	19,320	22,300				
4 No. 1RO Counterweights	7,660	9,450	10,865	7,545	11,715	11,050	12,980				
4 No. 1S Aux. Weights	9,565	11,550	13,215	9,450	14,070	13,400	15,630				
8 No. 1S Aux. Weights	11,470	13,650	15,565	11,355	16,425	15,750	18,280				
4 No. 2RO Counterweights	6,625	8,305	9,580	6,510	10,435	9,765	11,535				
4 No. 2S Aux. Weights	8,470	10,345	11,860	8,355	12,720	12,045	14,105				
8 No. 2S Aux. Weights	10,315	12,385	14,140	10,200	15,005	14,325	16,675				
4 No. 3CRO Counterweights	5,620	7,195	8,340	5,505	9,190	8,525	10,135				
4 No. 3BS Aux. Weights	7,410	9,170	10,550	7,295	11,400	10,735	12,625				
8 No. 3BS Aux. Weights	9,200	11,145	12,760	9,080	13,610	12,945	15,115*				
4 No. 5ARO Counterweights	-	-	-	-	-	-	8,505				
4 No. 5A Aux. Weights	-	-	-	-	-	-	10,165				
8 No. 5A Aux. Weights	-	-	-	-	-	-	11,825*				
4 No. 5CRO Counterweights	-	-	-	-	-	-	7,430				
4 No. 5CS Aux. Weights	-	-	-	-	-	-	8,945				
8 No. 5CS Aux. Weights	-	-	-	-	-	-	10,465				

Unit Size	C-456D-256-100	C-228D-213-100	C-320D-246-86	C-320D-213-86	C-160D-173-86	C-114D-119-86	C-320D-246-74	C-228D-200-74	C-160D-200-74
	C-320D-256-100	C-228D-173-100	C-228D-246-86	C-228D-213-86					
Maximum Stroke	100"	100"	86"	86"	86"	86"	74"		
Structural Unbalance	+ 550 lbs.	+ 0 lbs.	+ 800 lbs.	+ 450 lbs.	+ 450 lbs.	+ 115 lbs.	+ 800 lbs.		
Cranks	8495CA	7478CA	8495CA	7478CA	7478CA	6468CA	7478CA		
C'Bal., Cranks Only	7,330	3,910	8,720	4,910	4,910	3,395	5,960		
4 No. OARO Counterweights	22,510	-	-	-	-	-	-		
4 No. OAS Aux. Weights	27,210	-	-	-	-	-	-		
8 No. OAS Aux. Weights	-	-	-	-	-	-	-		
4 No. 1RO Counterweights	19,170	12,855	22,545	-	-	-	-		
4 No. 1S Aux. Weights	22,810	15,605	-	-	-	-	-		
8 No. 1S Aux. Weights	26,450	18,355	-	-	-	-	-		
4 No. 2RO Counterweights	17,195	11,425	20,235	13,490	13,490	10,430	15,870		
4 No. 2S Aux. Weights	20,725	14,120	-	16,560	16,560	-	19,425		
8 No. 2S Aux. Weights	24,260	16,810	-	19,635	-	-	-		
4 No. 3CRO Counterweights	15,330	10,090	18,065	11,965	11,965	9,255	14,110		
4 No. 3BS Aux. Weights	18,780	12,755	22,090	15,005	15,005	11,780	17,625		
8 No. 3BS Aux. Weights	22,230*	15,420*	-	18,045*	-	-	21,140*		
4 No. 5ARO Counterweights	13,180	8,510	15,550	10,160	10,160	7,830	12,025		
4 No. 5A Aux. Weights	15,525	10,355	18,290	12,265	12,265	9,605	14,460		
8 No. 5A Aux. Weights	17,870*	12,195*	21,030*	14,370*	14,370*	11,385	16,890***		
4 No. 5CRO Counterweights	11,640	7,310	13,750	8,795	8,795	6,685	10,445		
4 No. 5CS Aux. Weights	13,765	8,990	16,235	10,710	10,710	8,315	12,660		
8 No. 5CS Aux. Weights	15,895	10,670*	18,720	12,630*	12,630*	9,940	14,880***		
4 No. 6RO Counterweights	10,675	6,565	12,625	7,940	7,940	5,975	9,460		
4 No. 6 Aux. Weights	11,935	7,565	14,100	9,085	9,085	6,950	10,780		
8 No. 6 Aux. Weights	13,195	8,565	15,570	10,225	10,225	7,925	12,100		
4 No. 7RO Counterweights	9,465	5,615	11,210	6,855	6,855	5,060	8,205		
4 No. 7 Aux. Weights	10,420	6,375	12,330	7,725	7,725	5,805	9,210		
8 No. 7 Aux. Weights	11,375	7,135	13,445	8,595	8,595	6,550	10,215		

* Use only one aux. weight per counterweight on belt cover side on 912D, 320D & 160D units.

** Use only one aux. weight per counterweight on belt cover side on 320D & 228D units.

*** Use only one aux. weight per counterweight on belt cover side on 160D units.

CONVENTIONAL CRANK BALANCED PUMPING UNITS



C-912D-427-144 C-912D-365-144 C-640D-365-144	C-640D-305-144 C-456D-305-144	C-640D-256-144 C-456D-256-144 C-320D-256-144	C-640D-365-120 C-456D-365-120	C-640D-305-120 C-456D-305-120	C-456D-256-120 C-320D-256-120	C-456D-213-120 C-320D-213-120 C-228D-213-120
144" - 650 lbs.	144" - 520 lbs.	144" - 400 lbs.	120" + 570 lbs.	120" - 120 lbs.	120" + 55 lbs.	120" 0 lbs.
94110CA	94110CA	94110CA	94110CA	8495CA	8495CA	8495CA
6,190	6,360	6,480	8,670	5,570	5,740	5,685
-	-	-	-	-	-	-
-	-	-	-	-	-	-
-	-	-	-	-	-	-
23,710	23,970	-	29,415	-	-	-
28,995	29,285	-	35,670	-	-	-
34,285	-	-	-	-	-	-
21,475	21,725	21,845	26,765	20,430	20,595	-
26,550	26,825	-	32,775	25,365	-	-
31,625	-	-	-	-	-	-
19,125	19,360	19,480	23,980	18,305	18,470	18,415
23,130	23,385	23,505	28,725	22,250	22,415	-
27,130	27,410	-	33,465	26,190	-	-
16,250	16,470	16,590	20,580	15,505	15,670	15,615
19,345	19,580	19,700	24,240	18,555	18,725	18,670
22,435	22,690	22,810*	27,905	21,610	21,775	-
14,565	14,775	14,895	18,585	13,845	14,010	13,955
17,565	17,790	17,910	22,135	16,810	16,975	16,920
20,565	20,810	20,930*	25,690	19,770	19,935	19,880
12,935	13,135	13,255	16,650	12,285	12,450	12,395
15,840	16,055	16,175	20,095	15,175	15,345	15,290
18,745*	18,980	19,100*	23,535	18,070	18,235*	18,180**
11,025	11,200	11,340	14,395	10,475	10,645	10,590
12,965	13,165	13,285	16,690	12,445	12,615	12,560
14,905*	15,115	15,235*	18,985	14,410	14,580*	14,525*
9,775	9,960	10,080	12,910	9,185	9,355	9,300
11,545	11,740	11,860	15,005	10,970	11,140	11,085
13,315	13,520	*13,640	17,105	12,755	12,920	12,865

C-228D-173-74 C-160D-173-74	C-160D-143-74 C-114D-143-74	C-160D-173-64 C-114D-173-64	C-160D-143-64 C-114D-143-64	C-80D-119-64	C-114D-173-54	C-114D-133-54 C-80D-133-54
74" + 450 lbs.	74" + 300 lbs.	64" + 550 lbs.	64" + 360 lbs.	64" 0 lbs.	54" + 500 lbs.	54" + 330 lbs.
6468CA	6468CA	6468CA	5456CA	4850BA	5456CA	4850BA
4,235	4,090	4,880	2,665	2,155	3,190	2,845
-	-	-	-	-	-	-
-	-	-	-	-	-	-
-	-	-	-	-	-	-
-	-	-	-	-	-	-
-	-	-	-	-	-	-
-	-	-	-	-	-	-
-	-	-	-	-	-	-
-	-	-	-	-	-	-
11,005	10,870	12,630	8,605	-	10,115	-
13,925	13,790	15,965	11,165	-	13,105	-
16,840	-	-	13,725	-	16,090	-
9,360	9,220	10,745	7,290	6,120	8,585	7,470
11,410	11,275	13,090	9,145	7,740	10,745	9,360
13,465*	13,330*	15,440*	10,995*	-	12,910	11,250
8,040	7,900	9,235	6,120	5,135	7,220	6,320
9,915	9,780	11,380	7,830	6,610	9,210	8,040
11,795*	11,660*	13,530*	9,535*	-	11,205	9,760
7,220	7,075	8,295	5,400	4,515	6,380	5,595
8,345	8,205	9,580	6,430	5,405	7,580	6,635
9,470	9,330	10,870	7,460	6,295	8,785	7,675
6,160	6,015	7,085	4,440	3,700	5,260	4,645
7,020	6,880	8,070	5,235	4,395	6,190	5,460
7,880	7,740	9,050	6,030	5,090	7,115	6,270

EXAMPLE: A C-456D-256-120 Unit with 4 No. 2RO Counterweights and 4 No. 2S Auxiliary Weights would have a maximum counterbalance effect of 16,975 pounds in the 120" stroke. This effect includes a structural unbalance of +55 pounds. If the counterbalance effect is desired for the 85" stroke, subtract the structural unbalance from the effect in the 120" stroke and multiply this difference by the ratio of 120 ÷ 85, then add the structural unbalance to this product. Thus, counterbalance effect in the 85" stroke = [16,975 - (+55)] x 120/85 + (+55) = 16,920 x 120/85 + 55 = 23,942 pounds. Structural unbalance with a negative (-) sign indicates a walking beam assembly that is heavy on the well end. Structural unbalance without the negative sign indicates a walking beam assembly that is heavy on the gear reducer end.

Counterbalance Data (shown in lbs., effective at polished rod with weights at maximum position, including structural unbalance.)

Unit Size	C-80D-119-54	C-57D-76-54	C-80D-133-48	C-80D-109-48 C-57D-109-48 C-57D-95-48	C-57D-89-42 C-57D-76-42
Maximum Stroke	54"	54"	48"	48"	42"
Structural Unbalance	+ 300 lbs.	0 lbs.	+ 440 lbs.	+ 320 lbs.	+ 150 lbs.
Cranks	4850BA	4246BA	4850BA	4246BA	3644BA
C'Bal., Cranks Only	2,845	1,650	3,270	2,175	1,675
4 No. 5ARO Counterweights	7,470	5,760	8,475	6,800	-
4 No. 5A Aux. Weights	9,360	7,440	10,595	8,690	-
4 No. 5CRO Counterweights	6,320	4,750	7,175	5,665	5,300
4 No. 5CS Aux. Weights	8,040	6,285	9,115	7,395	7,165
4 No. 6RO Counterweights	5,595	4,120	6,365	4,955	4,700
4 No. 6 Aux. Weights	6,635	5,050	7,535	6,005	5,840
8 No. 6 Aux. Weights	7,675	5,985	8,705	7,055	6,985*
4 No. 7RO Counterweights	4,645	3,275	5,295	4,005	3,670
4 No. 7 Aux. Weights	5,460	4,005	6,210	4,830	4,570
8 No. 7 Aux. Weights	6,270	4,740	7,125	5,655	5,475*

* Use only one aux. weight per counterweight on belt cover side on 40D units.

NOTE: To convert effective counterbalance to maximum counterbalance torque for dynamometer card analysis, multiply the pounds counterbalance, minus the structural unbalance, by the torque factor at the 90° crank position.

LUFKIN

MARK II UNITORQUE PUMPING UNITS



The Mark II Pumping Unit, due to its unique geometry and phased counter-balance feature, lowers peak torque and horsepower requirements. The unusual geometry of the Mark II produces a somewhat slower up stroke and faster down stroke with reduced acceleration where the load is greatest, resulting in lower peak loads and longer rod life.

Mark II Geometry Reduces Rod Load and Peak Torque

The Mark II's unique UNITORQUE geometry is characterized by three basic configurations, which reduce the rod load and peak torque over that of a conventional pumping unit. The design characteristics which make the Mark II unique are:

- Shifting the gearbox from directly under the equalizer towards the Samson post turning in a preferred direction of rotation, creates an upstroke that occurs in approximately 195° of crank rotation and a downstroke of approximately 165° of crank rotation.
- Placing the equalizer between the horsehead and the Samson post creates a “push-up” or “Class 3” lever system.

The 195° upstroke, coupled with the front mounted geometry, reduces the acceleration at the beginning of the upstroke where the load is greatest, thereby effecting a reduction in polished rod load. Locating the cross-yoke forward of the gear reducer creates a greater mechanical advantage for lifting the heavy load on the upstroke, and a lesser mechanical advantage for the reduced downstroke load (i.e., the maximum upstroke torque factor is reduced while the maximum downstroke torque factor is increased).

- An angular offset in the crank that produces a more effective counterbalance torque which at the beginning of the upstroke “lags” the well load torque approximately 7½°. Similarly, at the beginning of the downstroke, this same offset condition produces a counter balance torque, which “leads” the well load torque approximately 7½°.

Independently these features would not produce a relatively uniform torque, but working together a “unitorque” system is obtained, which can reduce the torque on the gearbox up to 35%. Additionally, power costs can be lowered, and the prime mover size can often be reduced.

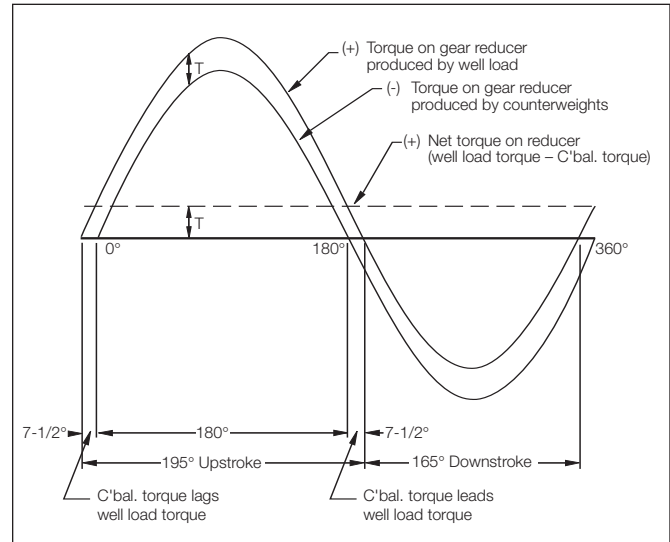

Uniform torque can be obtained under ideal conditions.

NOTE: The Mark II Unit must be operated in a counter-clockwise direction (standing at the side of the unit with the wellhead to the right).



“Two-Point” Suspension bases are standard for all Lufkin Mark II Pumping Units. The two-point base permits the use of small salvageable precast concrete blocks or fabricated foundation pads under the front and rear of the unit. Precast concrete blocks reduce concrete requirements by approximately 80%. This simple base suspension/foundation design significantly reduces installation time.

MARK II UNITORQUE PUMPING UNITS

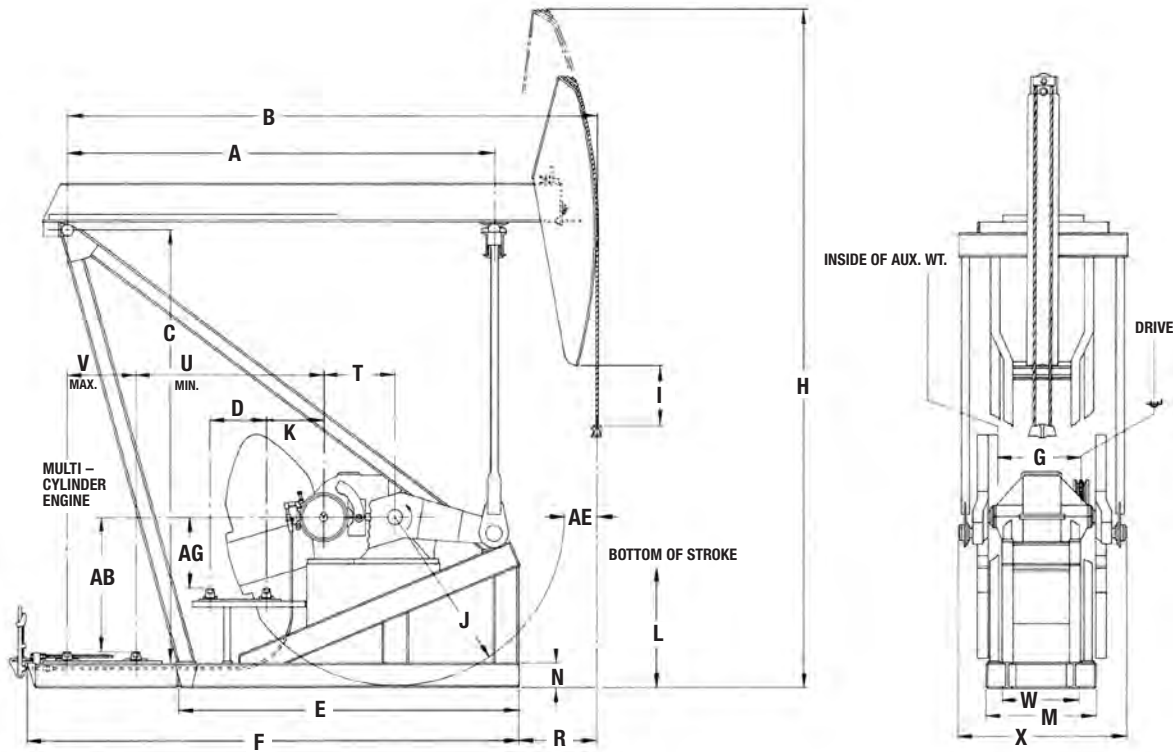

Dimensional Data (inches)

Unit Size	A	B	C	D	E	F	G	H	I	J	K	L	M	N	R	T	U	V	W	X	AB	AE	AG
M-1824D-427-216	306	384	329.88	55	223.00	333.75	67.00	569	44.38	130	25.38	75.50	101.00	18	45.00	58.88	105.88	52	48.50	124.00	108.50	26.00	51
M-1280D-427-216	306	384	329.88	55	223.00	341.50	57.25	569	44.38	130	31.75	75.50	96.00	18	45.00	52.50	120.00	52	48.50	114.00	108.50	26.00	51
M-1280D-427-192	306	384	329.88	55	223.00	341.50	57.25	550	63.25	130	31.75	80.25	96.00	18	45.00	52.50	120.00	52	48.50	114.00	108.50	26.00	51
M-912DS-365-216	306	384	329.88	55	223.00	331.50	53.63	569	44.38	130	23.00	75.50	96.00	18	45.00	48.50	109.50	52	48.50	107.00	108.50	26.00	59
M-912DS-427-192	306	384	329.88	55	223.00	331.50	53.63	550	63.25	130	23.00	75.38	96.00	18	45.00	48.50	109.50	52	48.50	107.00	108.50	26.00	59
M-912DS-427-168	270	334	276.88	50	218.75	298.25	53.63	477	32.38	108	25.50	85.25	81.50	18	48.00	48.50	108.38	52	50.00	107.00	114.38	23.38	46
M-912D-305-216	306	384	329.88	55	223.00	326.50	53.63	569	44.38	130	23.00	75.50	96.00	18	45.00	48.50	109.50	47	48.50	109.00	108.50	26.00	59
M-912D-305-192	306	384	329.88	55	223.00	326.50	53.63	550	63.25	130	23.00	80.25	96.00	18	45.00	48.50	109.50	47	48.50	109.00	108.50	26.00	59
M-912D-365-168	270	334	276.88	50	218.75	298.25	53.63	471	40.25	108	25.50	77.13	81.50	18	48.00	48.50	108.38	52	50.00	105.00	90.38	23.38	46
M-912D-305-168	270	334	276.88	50	218.75	298.25	53.63	471	40.25	108	25.50	77.13	81.50	18	48.00	48.50	108.38	52	50.00	105.00	90.38	23.38	46
M-912D-365-144	258	312	252.88	50	218.75	298.25	53.63	426	33.63	108	25.50	83.75	81.50	18	42.50	48.50	108.38	52	50.00	105.00	90.38	18.00	46
M-912D-305-144	258	312	252.88	50	218.75	298.25	53.63	426	33.63	108	25.50	83.75	81.50	18	42.50	48.50	108.38	52	50.00	103.38	90.38	18.00	46
M-640D-305-192	306	384	329.88	55	223.00	326.50	49.88	550	63.25	130	26.63	80.25	96.00	18	45.00	41.50	116.50	47	48.50	105.00	108.50	26.00	60
M-640D-365-168	270	334	276.88	50	218.75	298.25	49.88	471	40.25	108	24.13	77.13	81.50	18	48.00	41.50	115.25	52	50.00	101.00	90.38	23.38	46
M-640D-305-168	270	334	276.88	50	218.75	298.25	49.88	471	40.25	108	24.13	77.13	81.50	18	48.00	41.50	115.25	52	50.00	101.00	90.38	23.38	46
M-640D-365-144	258	312	252.88	50	218.75	298.25	49.88	426	33.63	108	24.13	83.75	81.50	18	42.50	41.50	115.25	52	50.00	101.00	90.38	18.00	46
M-640D-305-144	258	312	252.88	50	218.75	298.25	49.88	426	33.63	108	24.13	83.75	81.50	18	42.50	41.50	115.25	52	50.00	99.38	90.38	18.00	46
M-640D-256-144	258	312	252.88	50	218.75	298.25	49.88	422	47.25	108	24.13	71.63	81.50	18	42.50	41.50	115.25	52	50.00	99.38	90.38	18.00	46
M-640D-305-120	258	312	252.88	50	218.75	298.25	49.88	399	59.75	108	24.13	80.75	81.50	18	42.50	41.50	115.25	52	50.00	99.38	90.38	18.00	46
M-456D-305-192	306	384	329.88	55	223.00	326.50	49.88	550	63.25	130	29.75	80.25	96.00	18	45.00	38.38	119.63	47	48.50	105.00	108.50	26.00	60
M-456D-305-168	270	334	276.88	50	218.75	298.25	49.88	471	40.25	108	31.00	77.13	81.50	18	48.00	38.38	115.25	52	50.00	101.00	90.38	23.38	46
M-456D-365-144	258	312	252.88	50	218.75	298.25	49.88	426	33.63	108	31.00	83.75	81.50	18	42.50	38.38	115.25	52	50.00	101.00	90.38	18.00	46
M-456D-305-144	258	312	252.88	50	218.75	298.25	49.88	426	33.63	108	31.00	83.75	81.50	18	42.50	38.38	115.25	52	50.00	99.38	90.38	18.00	46
M-456D-256-144	258	312	252.88	50	218.75	298.25	49.88	434	47.50	108	31.00	71.63	81.50	18	42.50	38.38	115.25	52	50.00	99.38	90.38	18.00	46
M-456D-365-120	258	312	252.88	50	218.75	298.25	49.88	399	59.75	108	31.00	80.75	81.50	18	42.50	38.38	115.25	52	50.00	101.00	90.38	18.00	46
M-456D-305-120	258	312	252.88	50	218.75	298.25	49.88	399	59.75	108	31.00	80.75	81.50	18	42.50	38.38	115.25	52	50.00	99.50	90.38	18.00	46
M-456D-256-120	258	312	252.88	50	218.75	298.25	49.88	400	73.88	108	31.00	70.00	81.50	18	42.50	38.38	115.25	52	50.00	99.50	90.38	18.00	46

NOTE: Do not use the above dimensions for foundation. Request a foundation plan.
 The above units are designed to be installed on "two point" foundations.
 Popular API models shown, other models available on request.

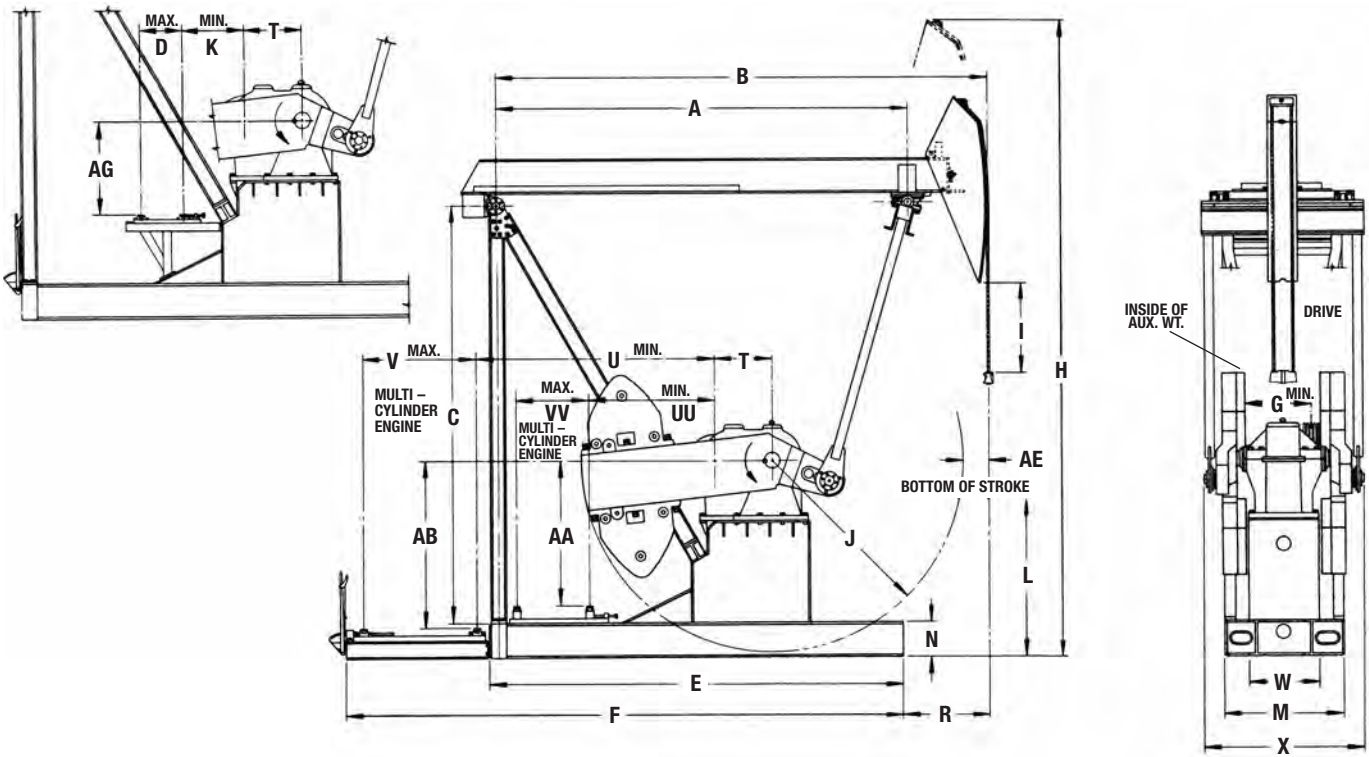

Dimensional Data (inches)

Unit Size*	A	B	C	D	E	F	G	H	I	J	K	L	M	N	R	T	U	V	W	X	AA	AB	AE	AG	UU	VV
M-320D-256-144	258	312	252.88	33.25	258.38	*	42.75	442	47.63	108.00	35.38	76.88	75.75	24	60	34	*	*	43	88.38	86	*	18.00	46.00	88	55
M-320D-305-120	258	312	252.88	33.25	258.38	*	42.75	407	65.00	108.00	35.38	87.00	75.75	24	60	34	*	*	43	88.38	86	*	18.00	46.00	88	55
M-320D-256-120	258	312	252.88	33.25	258.38	*	42.75	406	69.00	108.00	35.38	80.75	75.75	24	60	34	*	*	43	88.38	86	*	18.00	46.00	88	55
M-320D-213-120	258	312	252.88	33.25	258.38	*	42.75	406	69.00	108.00	35.75	80.75	75.75	24	60	34	*	*	43	88.38	86	*	18.00	46.00	88	55
M-320D-305-100	258	312	252.88	33.25	258.38	*	42.75	388	84.63	108.00	35.38	83.13	75.75	24	60	34	*	*	43	88.38	86	*	18.00	46.00	88	55
M-320D-256-100	258	312	252.88	33.25	258.38	*	42.75	381	88.38	108.00	35.38	81.25	75.75	24	60	34	*	*	43	88.38	86	*	18.00	46.00	88	55
M-228D-256-120	258	312	252.88	28.75	258.38	334.38	38.50	406	69.00	108.00	41.63	80.75	75.75	24	60	30	176.25	47.50	37	81.38	86	95.25	18.00	50.25	92	55
M-228D-213-120	258	312	252.88	28.75	258.38	334.38	38.50	406	69.00	108.00	41.63	80.75	75.75	24	60	30	176.25	47.50	37	81.38	86	95.25	18.00	50.25	92	55
M-228D-256-100	258	312	252.88	28.75	258.38	334.38	38.50	381	88.38	108.00	41.63	81.25	75.75	24	60	30	176.25	47.50	37	81.38	86	95.25	18.00	50.25	92	55
M-228D-173-100	258	312	252.88	28.75	258.38	*	38.50	381	88.38	108.00	41.63	81.25	75.75	24	60	30	176.25	47.50	37	81.38	86	95.25	18.00	50.25	92	55
M-228D-246-86	186	222	188.38	29.25	188.00	263.50	38.50	308	45.25	86.63	22.88	75.50	57.25	24	39	30	116.50	47.50	37	80.38	**	73.38	11.38	41.50	**	**
M-228D-213-86	186	222	188.38	29.25	187.63	263.13	38.50	305	45.25	86.63	22.88	72.50	57.25	21	39	30	116.13	47.50	37	103.38	**	70.38	11.38	41.50	**	**
M-228D-200-74	186	222	188.38	29.25	187.63	263.13	38.50	295	52.88	86.63	22.88	73.25	57.25	21	39	30	116.13	47.50	37	103.38	**	70.38	11.38	41.50	**	**
M-228D-173-74	186	222	188.38	29.25	187.63	263.13	38.50	294	52.88	86.63	22.88	72.88	57.25	21	39	30	116.13	47.50	37	103.38	**	70.38	11.38	41.50	**	**
M-160D-213-86	186	222	188.38	33.75	187.63	252.63	32.50	305	45.25	86.63	24.56	72.50	54.25	21	39	26	106.63	55.00	32	72.38	**	78.13	11.38	38.63	**	**
M-160D-173-86	186	222	188.38	33.75	187.63	252.63	32.50	305	41.13	86.63	24.56	72.13	54.25	21	39	26	106.63	55.00	32	72.38	**	78.13	11.38	38.63	**	**
M-160D-200-74	186	222	188.38	33.75	187.63	252.63	32.50	295	52.88	86.63	24.56	73.25	54.25	21	39	26	106.63	55.00	32	72.38	**	78.13	11.38	38.63	**	**
M-160D-173-74	186	222	188.38	30.00	187.63	252.63	32.50	294	52.88	86.63	24.56	72.88	54.25	21	39	26	106.63	55.00	32	72.38	**	78.13	11.38	38.63	**	**
M-114D-143-86	162	189	147.50	30.00	161.00	236.50	28.75	257	14.00	62.00	20.25	57.13	42.75	16	32	24	108.50	52.00	25	67.38	**	44.38	16.00	35.75	**	**
M-114D-173-74	186	222	188.38	30.75	188.38	263.13	28.75	294	52.88	86.63	28.00	72.88	54.25	21	39	24	122.13	52.00	25	69.00	**	70.38	11.38	41.63	**	**
M-114D-143-74	162	189	147.50	30.00	161.00	236.50	28.75	247	27.75	62.00	20.25	56.88	42.75	16	32	24	108.50	52.00	25	67.38	**	44.38	16.00	35.75	**	**
M-114D-173-64	162	189	147.50	30.00	161.00	236.50	28.75	238	21.00	62.00	20.25	71.63	42.75	16	32	24	108.50	52.00	25	67.38	**	44.38	16.00	35.75	**	**
M-114D-143-64	162	189	147.50	30.00	161.00	236.50	28.75	238	21.00	62.00	20.25	71.63	42.75	16	32	24	108.50	52.00	25	67.38	**	44.38	16.00	35.75	**	**

* On 100", 120" and 144" stroke units, on this page multi-cylinder engines are mounted on main base beams forward of Samson Post. See dimensions UU, VV, and AA.
 ** On 64", 74" and 86" stroke units, multi-cylinder engines are mounted behind the Samson Post. See dimensions U, V, and AB.

NOTE: Do not use the above dimensions for foundation. Request a foundation plan.
 The above units are designed to be installed on "two point" foundations.
 Popular API models shown, other models available on request.

MARK II UNITORQUE PUMPING UNITS



In 1976, when the United States celebrated its bicentennial, a Lufkin Mark II pumping unit was selected by the Smithsonian Museum of Natural History for display in its "Our Changing Land" exhibit.

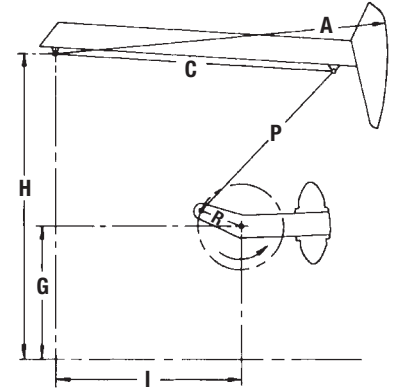

API Geometry Dimensions (inches)

Unit Size	A	C	I	P	H	G	R1, R2, R3, R4	PHASE ANGLE	S.U.*	T.F. @ (90° - ∞) /Stroke Length
M-1824D-427-216	384.00	306.00	228.00	234.38	346.00	132.00	80.06, 71.06, 62.06	22.0	-7450	93.734/216
M-1280D-427-216	384.00	306.00	228.00	234.38	346.00	132.00	80.06, 71.06, 62.06	22.0	-7450	93.734/216
M-912D-305-216	384.00	306.00	228.00	234.38	346.00	132.00	80.06, 71.06, 62.06	22.0	-7450	93.734/216
M-912DS-365-216	384.00	306.00	228.00	234.38	346.00	132.00	80.06, 71.06, 62.06	22.0	-7450	93.734/216
M-1280D-427-192	384.00	306.00	228.00	228.06	346.00	132.00	71.69, 62.69, 53.69	19.5	-7160	86.074/192
M-912DS-427-192	384.00	306.00	228.00	228.06	346.00	132.00	71.69, 62.69, 53.69	19.5	-7160	86.074/192
M-912D-305-192	384.00	306.00	228.00	228.06	346.00	132.00	71.69, 62.69, 53.69	19.5	-7160	86.074/192
M-640D-305-192	384.00	306.00	228.00	228.06	346.00	132.00	71.69, 62.69, 53.69	19.5	-7160	86.074/192
M-456D-305-192	384.00	306.00	228.00	228.06	346.00	132.00	71.69, 62.69, 53.69	19.5	-7160	86.074/192
M-912DS-427-168	334.00	270.00	203.00	196.50	295.13	112.13	63.56, 56.56, 49.56	19.0	-6820	75.207/168
M-912D-365-168	334.00	270.00	202.56	193.50	295.13	112.13	63.56, 56.56, 49.56	19.0	-5385	75.207/168
M-912D-305-168	334.00	270.00	202.56	193.50	295.13	112.13	63.56, 56.56, 49.56	19.0	-4860	75.207/168
M-640D-365-168	334.00	270.00	202.56	193.50	295.13	112.13	63.56, 56.56, 49.56	19.0	-5385	75.207/168
M-456D-305-168	334.00	270.00	202.56	193.50	295.13	112.13	63.56, 56.56, 49.56	19.0	-4860	75.207/168
M-912D-365-144	312.00	258.00	186.00	182.38	271.13	112.13	53.75, 47.75, 41.75	23.0	-4680	63.023/144
M-640D-365-144	312.00	258.00	186.00	182.38	271.13	112.13	53.75, 47.75, 41.75	23.0	-4680	63.023/144
M-456D-365-144	312.00	258.00	186.00	182.38	271.13	112.13	53.75, 47.75, 41.75	23.0	-4680	63.023/144
M-912D-305-144	312.00	258.00	186.00	182.38	271.13	112.13	53.75, 47.75, 41.75	23.0	-4300	63.023/144
M-640D-305-144	312.00	258.00	186.00	182.38	271.13	112.13	53.75, 47.75, 41.75	23.0	-4300	63.023/144
M-456D-305-144	312.00	258.00	186.00	182.38	271.13	112.13	53.75, 47.75, 41.75	23.0	-4300	63.023/144
M-640D-256-144	312.00	258.00	186.00	182.38	271.13	112.13	53.75, 47.75, 41.75	23.0	-4010	63.023/144
M-456D-256-144	312.00	258.00	186.00	182.38	271.13	112.13	53.75, 47.75, 41.75	23.0	-4010	63.023/144
M-320D-256-144	312.00	258.00	186.00	182.38	276.88	117.88	53.75, 47.75, 41.75	23.0	-4010	63.023/144
M-456D-365-120	312.00	258.00	186.00	173.75	271.88	112.13	45.13, 39.13, 33.13	24.0	-4510	53.595/120
M-640D-305-120	312.00	258.00	186.00	173.75	271.13	112.13	45.13, 39.13, 33.13	24.0	-4130	53.621/120
M-456D-305-120	312.00	258.00	186.00	173.75	271.13	112.13	45.13, 39.13, 33.13	24.0	-4130	53.621/120
M-320D-305-120	312.00	258.00	186.00	173.75	271.13	118.13	45.13, 39.13, 33.13	24.0	-4130	53.621/120
M-456D-256-120	312.00	258.00	186.00	173.75	271.13	112.13	45.13, 39.13, 33.13	24.0	-3840	53.621/120
M-320D-256-120	312.00	258.00	186.00	173.75	276.88	117.88	45.13, 39.13, 33.13	24.0	-3620	53.621/120
M-228D-256-120	312.00	258.00	186.00	173.75	276.88	117.88	45.13, 39.13, 33.13	24.0	-3435	53.621/120
M-320D-213-120	312.00	258.00	186.00	173.75	276.88	117.88	45.13, 39.13, 33.13	24.0	-3560	53.621/120
M-228D-213-120	312.00	258.00	186.00	173.75	276.88	117.88	45.13, 39.13, 33.13	24.0	-3235	53.621/120
M-320D-305-100	312.00	258.00	186.00	173.75	277.13	118.13	37.63, 31.63, 25.63	24.0	-3700	45.497/100
M-320D-256-100	312.00	258.00	186.00	173.75	276.88	117.88	37.63, 31.63, 25.63	24.0	-3470	45.497/100
M-228D-256-100	312.00	258.00	186.00	173.75	276.88	117.88	37.63, 31.63, 25.63	24.0	-3285	45.497/100
M-228D-173-100	312.00	258.00	186.00	173.75	276.88	117.88	37.63, 31.63, 25.63	24.0	-3175	45.497/100
M-228D-246-86	222.00	186.00	124.00	135.75	212.50	97.13	31.5, 26.5, 21.5	24.5	-2140	38.328/86
M-228D-213-86	222.00	186.00	124.00	135.75	209.50	94.13	31.5, 26.5, 21.5	24.5	-2040	38.328/86
M-160D-213-86	222.00	186.00	124.00	135.75	209.50	94.13	31.5, 26.5, 21.5	24.5	-2040	38.328/86
M-160D-173-86	222.00	186.00	124.00	135.75	209.50	94.13	31.5, 26.5, 21.5	24.5	-1930	38.328/86
M-114D-143-86	189.00	162.00	111.00	112.19	163.63	68.13	32.25, 27.75, 23.25	27.0	-1535	36.974/86
M-228D-200-74	222.00	186.00	124.00	130.50	209.50	94.13	27.25, 22.25, 17.25	24.5	-1960	33.523/74
M-160D-200-74	222.00	186.00	124.00	130.50	209.50	94.13	27.25, 22.25, 17.25	24.5	-1890	33.523/74
M-228D-173-74	222.00	186.00	124.00	130.50	209.50	94.13	27.25, 22.25, 17.25	24.5	-1860	33.523/74
M-160D-173-74	222.00	186.00	124.00	130.50	209.50	94.13	27.25, 22.25, 17.25	24.5	-1860	33.523/74
M-114D-173-74	222.00	186.00	124.00	130.50	209.50	94.13	27.25, 22.25, 17.25	24.5	-1820	33.523/74
M-114D-143-74	189.00	162.00	111.00	107.94	163.63	68.13	27.94, 23.44, 18.94	27.0	-1440	32.562/74
M-114D-173-64	189.00	162.00	111.00	107.94	163.63	68.13	24.19, 19.69, 15.19	28.0	-1420	28.549/64
M-114D-143-64	189.00	162.00	111.00	107.94	163.63	68.13	24.19, 19.69, 15.19	28.0	-1420	28.549/64

* Structural Unbalance in pounds.

Counterbalance Data (shown in lbs., effective at polished rod with weights at maximum position, including structural unbalance.)

Unit Size	M-912DS-365-216 M-1280D-427-216 M-1824D-427-216	M-912D-305-216	M-912DS-427-192 M-1280D-427-192	M-912D-305-192 M-640D-305-192 M-456D-305-192	M-912D-305-168 M-640D-305-168 M-456D-305-168	M-912D-305-168 M-640D-305-168 M-456D-305-168	M-912D-305-144 M-640D-305-144 M-456D-305-144	M-912D-305-144 M-640D-305-144 M-456D-305-144	M-640D-256-144 M-456D-256-144 M-320D-256-144
Maximum Stroke	216"	216"	192"	192"	168"	168"	168"	144"	144"
Structural Unbalance	-7,450 lbs.	-7,450 lbs.	-7,160 lbs.	-7,160 lbs.	-6,820 lbs.	-5,385 lbs.	-4,860 lbs.	-4,680 lbs.	-4,010 lbs.
Cranks	216130 MROA	216130 MROA	192130 MROA	192130 MROA	168108 MROA	168108 MROA	168108 MROA	144108 MROA	144108 MROA
C'Bal., Cranks Only	1,875	1,875	3,365	3,365	-975	460	985	3,090	3,470
4 No. OOROL Counterweights	22,150	22,150	25,445	25,445	18,620	20,065	-	-	-
4 No. OOSL Axu. Weights	28,130	28,130	31,955	-	24,415	25,850	-	-	-
8 No. OOSL Axu. Weights	34,110	-	38,470	-	30,180	31,635	-	-	-
4 No. 130RO Counterweights	21,605	21,605	24,850	24,850	-	-	-	-	-
4 No. 130D Aux. Weights	32,550	-	36,650	-	-	-	-	-	-
4 No. OORO Counterweights	17,990	17,990	20,920	20,920	14,605	16,040	16,565	21,690	22,065
4 No. OOS Aux. Weights	22,855	22,855	26,215	26,215	19,305	20,740	21,265	27,300	27,680
8 No. OOS Aux. Weights	27,720	27,720	31,510	-	24,005	25,440	25,965	32,910	-
4 No. ORO Counterweights	15,935	15,935	18,675	18,675	12,615	14,055	14,575	19,315	19,695
4 No. OS Aux. Weights	20,605	20,605	23,760	23,760	17,130	18,565	19,090	24,700	25,080
8 No. OS Aux. Weights	25,275	25,275	28,850	28,850	21,645	23,075	23,605	30,085	-
4 No. OARO Counterweights	13,595	13,595	16,130	16,130	10,510	11,945	12,470	16,795	17,180
4 No. OAS Aux. Weights	17,225	17,225	20,085	20,085	14,065	15,500	16,025	21,040	21,425
8 No. OAS Aux. Weights	20,855	20,855	24,040	24,040	17,620	19,055	19,580	25,285	25,670
4 No. 1RO Counterweights	10,970	10,970	13,275	13,275	7,965	9,400	9,925	13,755	14,135
4 No. 1S Aux. Weights	13,770	13,770	16,340	16,340	10,710	12,145	12,670	17,035	17,415
8 No. 1S Aux. Weights	16,570	16,570	19,365	19,365	13,455	14,890	15,415	20,315	20,695
4 No. 2RO Counterweights	9,430	9,430	11,590	11,590	6,460	7,895	8,420	11,965	12,345
4 No. 2S Aux Weights	12,135	12,135	14,535	14,535	9,125	10,560	11,085	15,145	15,525
8 No. 2S Aux. Weights	14,840	14,840	17,480	17,480	11,790	13,225	13,750	18,325	18,705
4 No. 3CRO Counterweights	7,910	7,910	9,940	9,940	5,015	6,450	6,975	10,240	10,620
4 No. 3BS Aux. Weights	10,515	10,515	12,775	12,775	7,595	9,030	9,555	13,320	13,700
8 No. 3BS Aux. Weights	13,120	13,120	15,605	15,605	10,175	11,610	12,135	16,400	16,780
4 No. 5ARO Counterweights	6,200	6,200	8,080	8,080	3,365	4,800	5,325	8,270	8,650
4 No. 5A Aux. Weights	7,950	7,950	9,970	9,970	5,110	6,555	7,080	10,365	10,745
8 No. 5A Aux. Weights	9,700	9,700	11,865	11,865	6,850	8,310	8,835	12,460	12,840
4 No. 5CRO Counterweights	5,050	5,050	6,820	6,820	2,220	3,655	4,180	6,895	7,275
4 No. 5CS Aux. Weights	6,620	6,620	8,530	8,530	3,795	5,230	5,755	8,780	9,160
8 No. 5CS Aux. Weights	8,190	8,190	10,240	10,240	5,370	6,805	7,330	10,665	11,045
4 No. 6RO Counterweights	4,285	4,285	5,985	5,985	1,445	2,880	3,405	5,970	6,350
4 No. 6 Aux. Weights	5,190	5,190	6,975	6,975	2,355	3,790	4,315	7,060	7,440
8 No. 6 Aux. Weights	6,095	6,095	7,965	7,965	3,265	4,700	5,225	8,150	8,530
4 No. 7RO Counterweights	3,400	3,400	5,025	5,025	565	2,000	2,525	4,925	5,305
4 No. 7 Aux. Weights	4,085	4,085	5,770	5,770	1,255	2,690	3,215	5,745	6,125
8 No. 7 Aux. Weights	4,770	4,770	6,515	6,515	1,945	3,380	3,905	6,565	6,945

Unit Size	M-320D-305-100	M-320D-256-100	M-228D-256-100	M-228D-173-100	M-228D-246-86	M-228D-213-86 M-160D-213-86	M-160D-173-86	M-114D-143-86
Maximum Stroke	100"	100"	100"	100"	86"	86"	86"	86"
Structural Unbalance	-3,700 lbs.	-3,470 lbs.	-3,285 lbs.	-3,175 lbs.	-2,140 lbs.	-2,040 lbs.	-1,930 lbs.	-1,535 lbs.
Cranks	100108 MRA	100108 MRA	100108 MRA	100108 MRA	8686 MRA	8686 MRA	8686 MRA	8662 MRA
C'Bal., Cranks Only	4,660	4,890	5,075	5,185	2,715	2,815	2,925	1,525
4 No. 1RO Counterweights	19,440	19,670	19,850	19,960	15,600	15,700	15,810	9,525
4 No. 1S Aux. Weights	23,980	24,210	24,395	-	19,565	19,665	19,775	11,980
4 No. 2RO Counterweights	16,955	17,185	17,370	17,480	13,480	13,580	13,690	8,270
4 No. 2S Aux Weights	21,360	21,590	21,775	-	17,335	17,435	17,545	10,690
4 No. 3CRO Counterweights	14,560	14,790	14,975	15,085	11,495	11,595	11,705	7,200
4 No. 3BS Aux. Weights	18,830	19,060	19,245	19,355	15,280	15,380	15,490	9,640
4 No. 5ARO Counterweights	11,840	12,070	12,255	12,365	9,190	9,290	9,400	5,880
4 No. 5A Aux. Weights	14,740	14,970	15,155	15,265	11,890	11,990	12,100	7,650
4 No. 5CRO Counterweights	9,935	10,165	10,350	10,460	7,495	7,595	7,705	4,770
4 No. 5CS Aux. Weights	12,545	12,775	12,960	13,070	9,860	9,955	10,070	6,375
4 No. 6RO Counterweights	8,655	8,885	9,070	9,180	6,435	6,535	6,645	4,080
4 No. 6 Aux. Weights	10,160	10,390	10,575	10,685	7,840	7,940	8,050	5,045
8 No. 6 Aux. Weights	11,665	11,895	12,080	12,190	9,245	-	-	6,010
4 No. 7RO Counterweights	7,200	7,430	7,615	7,725	5,095	5,195	5,305	3,180
4 No. 7 Aux. Weights	8,340	8,570	8,755	8,865	6,160	6,260	6,370	3,925
8 No. 7 Aux. Weights	9,480	9,710	9,895	10,005	7,225	-	-	4,680

* Use only 1 auxiliary weight per master weight on the M320D.

MARK II UNITORQUE PUMPING UNITS

Counterbalance Data (shown in lbs., effective at polished rod with weights at maximum position, including structural unbalance.)

Unit Size	M-456D-365-120	M-640D-305-120 M-456D-305-120 M-320D-305-120	M-456D-256-120	M-320D-256-120	M-228D-256-120	M-320D-213-120	M-228D-213-120
	120"	120"	120"	120"	120"	120"	120"
Maximum Stroke	120"	120"	120"	120"	120"	120"	120"
Structural Unbalance	- 4,510 lbs.	- 4,130 lbs.	- 3,840 lbs.	- 3,620 lbs.	- 3,435 lbs.	- 3,560 lbs.	- 3,235 lbs.
Cranks	120108 MRA	120108 MRA	120108 MRA	120108 MRA	120108 MRA	120108 MRA	120108 MRA
C'Bal., Cranks Only	1,990	2,370	2,660	2,880	3,070	2,940	3,270
4 No. ORO Counterweights	21,065	21,440	21,735	21,955	22,140	-	-
4 No. OS Aux. Weights	27,405	27,775	-	-	-	-	-
8 No. OS Aux. Weights	33,740	-	-	-	-	-	-
4 No. OARO Counterweights	18,105	18,485	18,775	18,995	19,180	19,055	19,380
4 No. OAS Aux. Weights	23,095	23,475	23,765	23,985	24,170	-	-
8 No. OAS Aux. Weights	28,085	28,465*	-	-	-	-	-
4 No. 1RO Counterweights	14,530	14,910	15,200	15,420	15,605	15,480	15,805
4 No. 1S Aux. Weights	18,385	18,765	19,055	19,275	19,460	19,335	19,660
8 No. 1S Aux. Weights	22,240	22,620*	22,910	-	-	-	-
4 No. 2RO Counterweights	12,425	12,805	13,095	13,315	13,500	13,375	13,700
4 No. 2S Aux. Weights	16,165	16,545	16,855	17,055	17,240	17,115	17,440
8 No. 2S Aux. Weights	19,905	20,285*	20,575	-	-	-	-
4 No. 3CRO Counterweights	10,395	10,775	11,065	11,285	11,470	11,345	11,670
4 No. 3BS Aux. Weights	14,015	14,395	14,685	14,905	15,090	14,965	15,290
8 No. 3BS Aux. Weights	17,635	18,015*	18,305	-	-	-	-
4 No. 5ARO Counterweights	8,085	8,465	8,755	8,975	9,160	9,035	9,360
4 No. 5A Aux. Weights	10,545	10,925	11,215	11,435	11,620	11,495	11,820
8 No. 5A Aux. Weights	13,005	13,385*	13,675	-	-	-	-
4 No. 5CRO Counterweights	6,470	6,845	7,140	7,360	7,545	7,420	7,745
4 No. 5CS Aux. Weights	8,685	9,060	9,355	9,575	9,755	9,630	9,960
8 No. 5CS Aux. Weights	10,900	11,275*	11,570	-	-	-	-
4 No. 6RO Counterweights	5,385	5,765	6,055	6,275	6,460	6,335	6,660
4 No. 6 Aux. Weights	6,665	7,040	7,330	7,550	7,735	7,610	7,935
8 No. 6 Aux. Weights	7,945	8,315	8,605	8,825	9,010	8,885	9,210
4 No. 7RO Counterweights	4,150	4,530	4,820	5,040	5,225	5,100	5,425
4 No. 7 Aux. Weights	5,115	5,495	5,785	6,005	6,190	6,065	6,390
8 No. 7 Aux. Weights	6,080	6,460	6,750	6,970	7,155	7,030	7,355

* Use only 1 auxiliary weight per master weight on the M320D.

Unit Size	M-228D-200-74	M-160D-200-74	M-228D-173-74 M-160D-173-74	M-114D-173-74	M-114D-143-74	M-114D-173-64 M-114D-143-64
	74"	74"	74"	74"	74"	64"
Maximum Stroke	74"	74"	74"	74"	74"	64"
Structural Unbalance	- 1,960 lbs.	- 1,890 lbs.	- 1,860 lbs.	- 1,820 lbs.	- 1,440 lbs.	- 1,420 lbs.
Cranks	7486 MRA	7486 MRA	7486 MRA	7486 MRA	7462 MRA	6462 MRA
C'Bal., Cranks Only	3,685	3,755	3,785	3,825	2,230	2,845
4 No. 2RO Counterweights	15,990	16,060	16,090	16,130	9,890	11,580
4 No. 2S Aux. Weights	-	-	-	-	12,630	14,710
4 No. 3CRO Counterweights	13,720	13,790	13,820	13,860	8,670	10,190
4 No. 3BS Aux. Weights	18,045	18,115	18,145	18,185	11,445	13,355
4 No. 5ARO Counterweights	11,085	11,155	11,185	11,225	7,170	8,485
4 No. 5A Aux. Weights	14,080	14,150	14,180	14,220	9,180	10,775
4 No. 5CRO Counterweights	9,145	9,215	9,245	9,285	5,910	7,045
4 No. 5CS Aux. Weights	11,845	11,915	11,945	11,985	7,730	9,125
4 No. 6RO Counterweights	7,935	8,005	8,035	8,075	5,130	6,150
4 No. 6 Aux. Weights	9,540	9,610	9,640	9,680	6,225	7,400
8 No. 6 Aux. Weights	11,145	-	-	11,285	7,320	8,650
4 No. 7RO Counterweights	6,400	6,470	6,500	6,540	4,105	4,985
4 No. 7 Aux. Weights	7,625	7,695	7,725	7,765	4,950	5,950
8 No. 7 Aux. Weights	8,850	-	-	8,900	5,795	6,915

EXAMPLE: A M-456D-365-120 with 4 No. ORO Counterweights and 4 No. OS Auxiliary Weights would have a maximum counterbalance effect of 27,395 lbs. in the 120" stroke. Structural Unbalance with a negative (-) sign indicates a walking beam assembly that is heavy on the well end.

Structural Data

Unit Size	Polished Rod Capacity (lbs.)	Stroke Lengths (inches)	Walking Beam	Crank Pin Bearing	Samson Post Bearing	Cross Yoke Bearing	Wireline Hanger (inches)	Cranks
M-1824D-427-216	42,700	216, 192, 167	W24 x 131	1SE	P19	C232	1.38 x 16 CTRS.	216130 MROA
M-1280D-427-216	42,700	216, 192, 167	W24 x 131	1SE	P19	C232	1.38 x 16 CTRS.	216130 MROA
M-912DS-365-216	36,500	216, 192, 167	W24 x 131	1SE	P19	C232	1.38 x 16 CTRS.	216130 MROA
M-912D-365-216	36,500	216, 192, 167	W24 x 131	1SE	P19	C232	1.38 x 16 CTRS.	216130 MROA
M-912D-305-216	30,500	216, 192, 167	W24 x 131	1SE	P19	C232	1.38 x 16 CTRS.	216130 MROA
M-1280D-427-192	42,700	192, 168, 144	W24 x 131	1SE	P19	C232	1.38 x 16 CTRS.	192130 MROA
M-912DS-427-192	42,700	192, 168, 144	W24 x 131	1SE	P19	C232	1.38 x 16 CTRS.	192130 MROA
M-912D-305-192	30,500	192, 168, 144	W24 x 131	1SE	P19	C232	1.38 x 16 CTRS.	192130 MROA
M-640D-305-192	30,500	192, 168, 144	W24 x 131	1SE	P19	C232	1.38 x 16 CTRS.	192130 MROA
M-456D-305-192	30,500	192, 168, 144	W24 x 131	1SE	P19	C232	1.38 x 16 CTRS.	192130 MROA
M-912DS-427-168	42,700	168, 150, 131	W24 x 131	1SE	P19	C232	1.38 x 16 CTRS.	168108 MROA
M-912D-365-168	36,500	168, 149, 130	W24 x 104	1SE	P18	C22 C	1.38 x 12 CTRS.	168108 MROA
M-640D-365-168	36,500	168, 149, 130	W24 x 104	1SE	P18	C22 C	1.38 x 12 CTRS.	168108 MROA
M-912D-305-168	30,500	168, 149, 130	W24 x 84	1SE	P18	C22 C	1.25 x 12 CTRS.	168108 MROA
M-640D-305-168	30,500	168, 149, 130	W24 x 84	1SE	P18	C22 C	1.25 x 12 CTRS.	168108 MROA
M-456D-305-168	30,500	168, 149, 130	W24 x 84	1SE	P18	C22 C	1.25 x 12 CTRS.	168108 MROA
M-912D-365-144	36,500	144, 128, 112	W24 x 84	1SE	P18	C232	1.38 x 12 CTRS.	144108 MROA
M-640D-365-144	36,500	144, 128, 112	W24 x 84	1SE	P18	C232	1.38 x 12 CTRS.	144108 MROA
M-456D-365-144	36,500	144, 128, 112	W24 x 84	1SE	P18	C232	1.38 x 12 CTRS.	144108 MROA
M-912D-305-144	30,500	144, 128, 112	W24 x 84	2SE	P18	C22 C	1.25 x 12 CTRS.	144108 MROA
M-640D-305-144	30,500	144, 128, 112	W24 x 84	2SE	P18	C22 C	1.25 x 12 CTRS.	144108 MROA
M-456D-305-144	30,500	144, 128, 112	W24 x 84	2SE	P18	C22 C	1.25 x 12 CTRS.	144108 MROA
M-640D-256-144	25,600	144, 128, 112	W21 x 68	2SE	P18	C22 C	1.13 x 9 CTRS.	144108 MROA
M-456D-256-144	25,600	144, 128, 112	W21 x 68	2SE	P18	C22 C	1.13 x 9 CTRS.	144108 MROA
M-320D-256-144	25,600	144, 128, 112	W21 x 68	2SE	P18	C22 C	1.13 x 9 CTRS.	144108 MROA
M-456D-365-120	36,500	120, 104, 88	W24 x 84	1SE	P18	C232	1.38 x 12 CTRS.	120108 MRA
M-640D-305-120	30,500	120, 104, 88	W24 x 84	2SE	P18	C22 C	1.25 x 12 CTRS.	120108 MRA
M-456D-305-120	30,500	120, 104, 88	W24 x 84	2SE	P18	C22 C	1.25 x 12 CTRS.	120108 MRA
M-320D-305-120	30,500	120, 104, 88	W24 x 84	2SE	P18	C22 C	1.25 x 12 CTRS.	120108 MRA
M-456D-256-120	25,600	120, 104, 88	W21 x 68	2SE	P18	C22 C	1.13 x 9 CTRS.	120108 MRA
M-320D-256-120	25,600	120, 104, 88	W21 x 68	2SE	P18	C22 C	1.13 x 9 CTRS.	120108 MRA
M-228D-256-120	25,600	120, 104, 88	W21 x 68	2SE	P18	C20	1.13 x 9 CTRS.	120108 MRA
M-320D-213-120	21,300	120, 104, 88	W21 x 62	2SE	P18	C22 C	1.13 x 9 CTRS.	120108 MRA
M-228D-213-120	21,300	120, 104, 88	W21 x 62	2SE	P16	C19	1.13 x 9 CTRS.	120108 MRA
M-320D-305-100	30,500	100, 84, 68	W24 x 84	2SE	P18	C22 C	1.25 x 12 CTRS.	100108 MRA
M-320D-256-100	25,600	100, 84, 68	W21 x 68	2SE	P18	C22 C	1.25 x 9 CTRS.	100108 MRA
M-228D-256-100	25,600	100, 84, 68	W21 x 68	2SE	P18	C20	1.25 x 9 CTRS.	100108 MRA
M-228D-173-100	17,300	100, 84, 68	W16 x 57	2SE	P16	C19	1.25 x 9 CTRS.	100108 MRA
M-228D-246-86	24,600	86, 72.4, 58.6	W16 x 57	2SE	P16	C20N	1.25 x 9 CTRS.	8686 MRA
M-228D-213-86	21,300	86, 72.4, 58.6	W16 x 45	2SE	P16	C20N	1.25 x 9 CTRS.	8686 MRA
M-160D-213-86	21,300	86, 72.4, 58.6	W16 x 45	2SE	P16	C20N	1.25 x 9 CTRS.	8686 MRA
M-160D-173-86	17,300	86, 72.4, 58.6	W16 x 45	2SE	P13	C18N	1.25 x 9 CTRS.	8686 MRA
M-114D-143-86	14,300	86, 74, 62	W14 x 34	4SF	P13	C18N	1.00 x 9 CTRS.	8686 MRA
M-228D-200-74	20,000	74, 60.4, 46.8	W16 x 45	2SE	P16	C20N	1.00 x 9 CTRS.	7486 MRA
M-160D-200-74	20,000	74, 60.4, 46.8	W16 x 45	2SE	P16	C20N	1.00 x 9 CTRS.	7486 MRA
M-228D-173-74	17,300	74, 60.4, 46.8	W16 x 45	2SE	P13	C18N	1.00 x 9 CTRS.	7486 MRA
M-160D-173-74	17,300	74, 60.4, 46.8	W16 x 45	2SE	P13	C18N	1.00 x 9 CTRS.	7486 MRA
M-114D-173-74	17,300	74, 60.4, 46.8	W16 x 45	3SF	P13	C18N	1.00 x 9 CTRS.	7486 MRA
M-114D-143-74	14,300	74, 60, 46	W14 x 34	4SF	P13	C18N	1.00 x 9 CTRS.	7462 MRA
M-114D-173-64	17,300	64, 52, 40	W14 x 34	3SF	P13	C18N	1.00 x 9 CTRS.	6462 MRA
M-114D-143-64	14,300	64, 52, 40	W14 x 34	4SF	P13	C18N	1.00 x 9 CTRS.	6462 MRA

LUFKIN

AIR BALANCED PUMPING UNITS



The utilization of compressed air instead of heavy cast iron counterweights allows more accurate fingertip control of counterbalance. As a result, the weight of the unit is greatly reduced, significantly lowering transportation and installation costs. Air Balanced units have a distinct advantage in the larger sizes with long strokes, where space and weight restrictions prohibit the use of conventional crank balanced units.

Air Balanced Pumping Units provide:

- Perfect counterbalance with finger-tip control.
- Lower installation cost.
- Compact and portable; ideal for well testing.
- Small size and lighter weight make unit ideal for export.
- Stroke lengths to 20 feet for high volume production from great depths.

These are some of the outstanding advantages of Lufkin Air Balanced Pumping Units. These units employ compressed air to counterbalance the well load rather than beam weights or crank weights. The air system has been so simplified that the only continuously operating parts are the balance cylinder and piston. The reservoir capacity of the cylinder is enlarged by a steel receiver which moves with the cylinder as a unit.

On engine-driven units, when the system is in need of air, an automatic regulator engages an air operated clutch (driven by one belt from the unit sheave) and replaces any lost air. The operator sets the regulator, initially, at a pressure sufficient to counterbalance the well load. Then, this pressure is maintained automatically. Should the load change appreciably, a slight adjustment of the regulator will restore perfect counterbalance.

A safety shut-off switch is available, which will ground out the engine, or shut off the motor, if pressure should exceed a preset figure or fall below a minimum pre-set figure.

For units pumping with electricity, a separate motor-driven compressor assembly is standard equipment.

Lufkin Air Balanced Units are approximately 35% shorter and 40% lighter than crank-type units, which makes them ideal for use as portable or test units, and for installation on piling or superstructures. Since changing counterbalance effect is a matter of adjusting a valve, air balanced units are ideal for use in testing wells.

All of the ruggedness and simplicity of conventional Lufkin Pumping Units are incorporated in the design of Lufkin's Air Balanced Pumping Units.

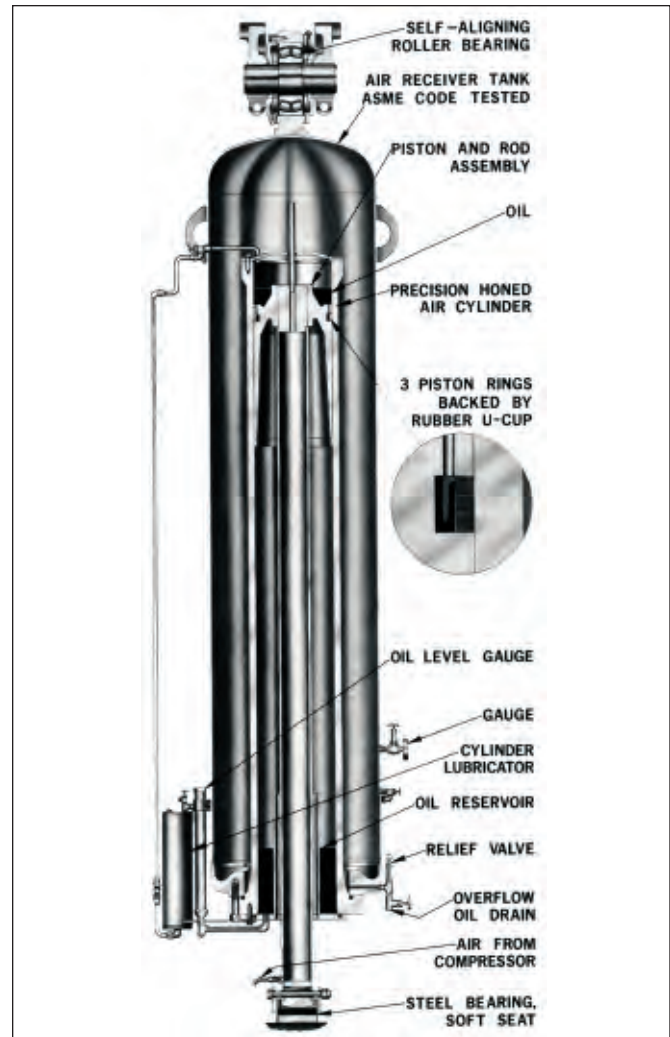

A Lufkin Air Balanced Unit with electric motor drive.

AIR BALANCED PUMPING UNITS

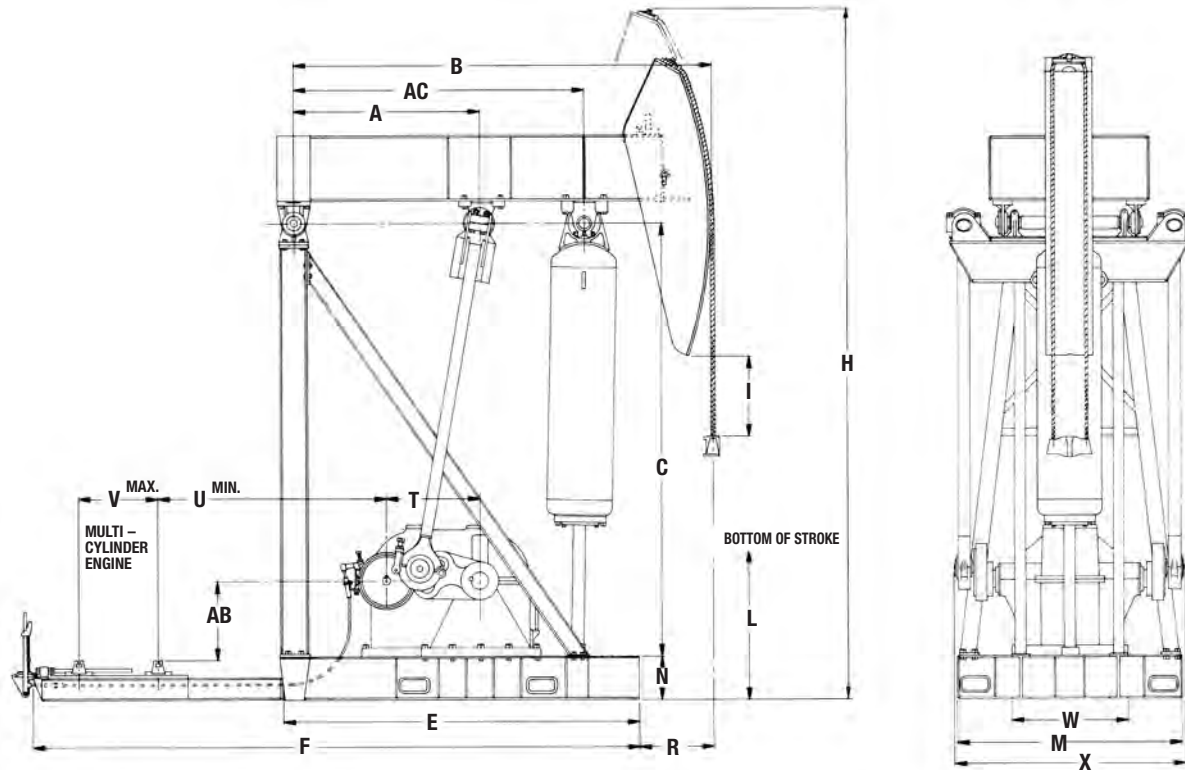

Dimensional Data (inches)

Unit Size	A	B	C	E	F	H	I	L	M	N	R	T	U	V	W	X	AB	AC
A-2560D-470-240	134.5	336	303.5	*	379.25	558.5	19.38	54.00	106.00	21.00	51.69	70.00	100.38	46.50	66.25	130.63	39.13	233.5
A-1824D-470-240	134.5	336	303.5	*	379.25	558.5	19.38	54.00	96.00	21.00	51.69	58.88	111.50	46.50	50.25	115.63	33.13	233.5
A-1824D-427-216	121.5	308	282.0	264.88	354.88	516.0	20.63	56.13	95.50	21.00	48.00	58.88	96.00	46.50	50.25	115.63	33.13	171.5
A-1824D-427-192	121.5	276	252.0	232.88	322.88	464.0	19.38	50.13	95.50	21.00	48.00	58.88	96.00	46.50	50.25	115.63	33.13	171.5
A-1280D-470-240	134.5	336	303.5	*	379.25	558.5	19.38	54.00	96.00	21.00	51.69	52.50	117.88	46.50	50.25	109.63	33.13	233.5
A-1280D-427-216	121.5	308	282.0	264.88	354.88	516.0	20.63	56.13	95.50	21.00	48.00	52.50	102.38	46.50	50.25	109.63	33.13	171.5
A-1280D-427-192	121.5	276	252.0	232.88	322.88	464.0	19.38	50.13	95.50	21.00	48.00	52.50	102.38	46.50	50.25	109.63	33.13	171.5
A-1280D-305-168	88.0	231	244.0	178.50	264.50	426.0	17.63	65.25	95.50	16.13	59.00	52.50	71.75	40.50	50.25	107.13	36.38	131.5
A-912D-470-240	134.5	336	303.5	*	379.25	558.5	19.38	54.00	96.00	21.00	51.69	48.50	121.88	46.50	50.00	102.63	33.13	233.5
A-912D-427-216	121.5	308	282.0	264.88	354.88	516.0	20.63	56.00	95.50	21.00	48.00	48.50	109.38	46.50	50.00	102.63	27.13	171.5
A-912D-427-192	121.5	276	252.0	232.88	322.88	464.0	19.38	50.00	95.50	21.00	48.00	48.50	109.38	46.50	50.00	102.63	27.13	171.5
A-912D-305-168	88.0	231	244.0	178.50	264.50	426.0	17.63	65.25	95.50	16.13	59.00	48.50	75.75	40.50	50.00	100.13	30.38	131.5
A-912D-427-144	88.0	200	214.0	147.50	233.50	375.5	19.38	56.00	95.50	16.13	59.00	48.50	75.75	40.50	50.00	100.13	30.38	131.5
A-640D-305-168	88.0	231	244.0	178.50	264.50	426.0	17.63	65.25	95.50	16.13	59.00	41.50	83.75	40.50	46.75	100.13	28.38	131.5
A-640D-427-144	88.0	200	214.0	147.50	233.50	375.5	19.38	56.00	95.50	16.13	59.00	41.50	83.75	40.50	46.75	100.13	28.38	131.5
A-640D-305-144	77.0	208	214.0	155.25	241.25	372.0	21.13	54.88	91.00	16.13	57.00	41.50	71.00	40.50	46.75	100.13	28.38	118.0
A-640D-365-120	77.0	175	187.0	131.75	217.75	324.0	22.50	50.00	91.00	16.13	47.50	41.50	71.00	40.50	46.75	100.13	28.38	118.0
A-456D-305-144	77.0	208	214.0	155.25	241.25	372.0	21.13	54.88	91.00	16.13	57.00	38.38	74.13	40.50	46.75	100.13	28.38	118.0
A-456D-365-120	77.0	175	187.0	131.75	217.75	324.0	22.50	50.00	91.00	16.13	47.50	38.38	74.13	40.50	46.75	100.13	28.38	118.0
A-456D-256-120	69.0	184	187.0	143.75	229.75	324.0	17.25	56.13	85.50	16.13	53.00	38.38	74.13	40.50	46.75	100.13	28.38	107.0
A-320D-256-120	70.0	184	187.0	135.25	227.25	324.0	17.25	56.00	85.50	16.13	53.00	34.00	71.25	40.50	43.25	87.38	30.13	107.0
A-320D-305-100	70.0	155	160.0	120.25	212.25	280.0	25.50	40.38	85.50	16.13	39.00	34.00	71.25	40.50	43.25	87.38	30.13	107.0
A-228D-173-100	56.0	151	149.0	99.25	177.00	267.0	15.00	40.50	73.50	16.13	56.00	30.00	47.00	40.50	37.25	80.38	29.13	87.5
A-228D-246-86	56.0	131	149.0	99.25	177.00	255.0	18.13	50.75	73.50	16.13	36.00	30.00	47.00	40.50	37.25	80.38	29.13	87.5
A-160D-200-74	50.0	120	141.0	95.00	174.75	231.0	18.88	49.50	73.50	9.75	35.50	26.00	53.75	48.00	32.00	69.88	15.88	77.5
A-114D-173-64	48.0	115	132.0	89.50	173.75	212.0	20.38	50.38	63.75	9.75	36.00	24.00	62.00	46.00	25.25	66.88	11.88	72.5

* Portable base is standard. One piece and portable bases available on all units.
NOTE: Do not use above dimensions for foundation. Request foundation plan.

In 1971, a Lufkin Air-Balanced pumping unit was chosen to dewater the test chamber for the Atomic Energy Commission's nuclear underground test on Amchitka Island, Alaska.

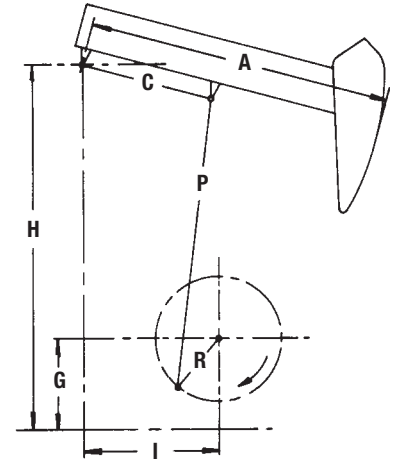

API Geometry Dimensions (inches)

Unit Size	A	C	I	P	H	G	R1, R2, R3	M	S
A-2560D-470-240	336	134.5	130.0	261.5	303.5	42	47, 39.44	114.80	150.00
A-1824D-470-240	336	134.5	130.0	267.5	303.5	36	47, 39.44	114.80	150.00
A-1280D-470-240	336	134.5	130.0	267.5	303.5	36	47, 39.44	114.80	150.00
A-912D-470-240	336	134.5	130.0	267.5	303.5	36	47, 39.44	114.80	150.00
A-1824D-427-216	308	121.5	114.5	246.0	282.0	36	41.75, 36.63, 32	92.00	140.00
A-1280D-427-216	308	121.5	114.5	246.0	282.0	36	41.75, 36.63, 32	92.00	140.00
A-912D-427-216	308	121.5	117.5	252.0	282.0	30	41.75, 36.63, 32	92.00	140.00
A-1824D-427-192	276	121.5	114.5	216.0	252.0	36	41.75, 36.63, 32	102.80	112.00
A-1280D-427-192	276	121.5	114.5	216.0	252.0	36	41.75, 36.63, 32	102.80	112.00
A-912D-427-192	276	121.5	117.5	222.0	252.0	30	41.75, 36.63, 32	102.80	112.00
A-1280D-305-168	231	88.0	84.0	208.0	244.0	36	31.25, 26.19, 22	75.54	112.81
A-912D-305-168	231	88.0	84.0	214.0	244.0	30	31.25, 26.19, 22	75.54	112.81
A-640D-305-168	231	88.0	85.0	216.0	244.0	28	31.25, 26.19, 22	75.54	112.81
A-912D-427-144	200	88.0	84.0	184.0	214.0	30	31.25, 26.19, 22	87.30	90.00
A-640D-427-144	200	88.0	85.0	186.0	214.0	28	31.25, 26.19, 22	87.30	90.00
A-640D-305-144	208	77.0	74.5	186.0	214.0	28	26.19, 22, 18.94	64.16	95.16
A-456D-305-144	208	77.0	74.5	186.0	214.0	28	26.19, 22, 18.94	64.16	95.16
A-640D-365-120	175	77.0	74.5	159.0	187.0	28	26.19, 22, 18.94	76.20	88.00
A-456D-365-120	175	77.0	74.5	159.0	187.0	28	26.19, 22, 18.94	76.20	88.00
A-456D-256-120	184	69.0	66.0	159.0	187.0	28	22, 18.94, 16.31	55.25	77.00
A-320D-256-120	184	70.0	68.0	159.0	187.0	28	22.38, 19.38, 16.75	55.25	77.00
A-320D-305-100	155	70.0	68.0	132.0	160.0	28	22.38, 19.38, 16.75	65.60	76.00
A-228D-173-100	151	56.0	54.0	122.0	149.0	27	18.25, 15.75, 13.75	45.49	85.75
A-228D-246-86	131	56.0	54.0	122.0	149.0	27	18.25, 15.75, 13.75	52.50	73.00
A-160D-200-74	120	50.0	48.0	114.0	141.0	27	15.25, 13.25, 11.25	50.70	63.00
A-114D-173-64	115	48.0	46.5	114.0	132.0	18	13.31, 11.25	31.70	63.00

AIR BALANCED PUMPING UNITS

Structural Data

Unit Size	Polish Rod Capacity (lbs.)	Stroke Lengths (inches)	Piston Dia. (inches)	Walking Beam	Wireline Hanger (inches)	Floating Hub Sheave* Sizes, P.D. (inches)	Crank Pin Bearing	Equalizer Bearing	Samson Post Bearing	Air Tank Bearing
A-2560D-470-240	47,000	240, 200	14.5	W36 x 247	1.38 x 16 CTRS.	68 (12D)	OT	E32	P19	334
A-1824D-470-240	47,000	240, 200	14.5	W36 x 247	1.38 x 16 CTRS.	40, 46, 51, 55, 68 (11D)	OT	E26	P19	334
A-1824D-427-216	42,700	216, 190, 162	14.5	W33 x 201	1.38 x 16 CTRS.	40, 46, 51, 55, 68 (11D)	OT	E26	P19	334
A-1824D-427-192	42,700	192, 168, 144	14.5	W33 x 201	1.38 x 16 CTRS.	40, 46, 51, 55, 68 (11D)	OT	E26	P19	334
A-1280D-470-240	47,000	240, 200	14.5	W36 x 247	1.38 x 16 CTRS.	40, 46, 51, 55, 68 (10D)	OT	E26	P19	334
A-1280D-427-216	42,700	216, 190, 162	14.5	W33 x 201	1.38 x 16 CTRS.	40, 46, 51, 55, 68 (10D)	OT	E26	P19	334
A-1280D-427-192	42,700	192, 168, 144	14.5	W33 x 201	1.38 x 16 CTRS.	40, 46, 51, 55, 68 (10D)	OT	E26	P19	334
A-1280D-305-168	30,500	168, 141, 118	13.0	W27 x 161	1.38 x 16 CTRS.	40, 46, 51, 55, 68 (10D)	OT	E26	P19	232
A-912D-470-240	47,000	240, 200	14.5	W36 x 247	1.38 x 16 CTRS.	28, 34, 40, 46, 51 (8D)	OT	E26	P19	334
A-912D-427-216	42,700	216, 190, 162	14.5	W33 x 201	1.38 x 16 CTRS.	28, 34, 40, 46, 51 (8D)	OT	E26	P19	334
A-912D-427-192	42,700	192, 168, 144	14.5	W33 x 201	1.38 x 16 CTRS.	28, 34, 40, 46, 51 (8D)	OT	E26	P19	334
A-912D-305-168	30,500	168, 141, 118	13.0	W27 x 146	1.38 x 16 CTRS.	28, 34, 40, 46, 51 (7D)	OT	E26	P19	232
A-912D-427-144	42,700	144, 120, 100	13.0	W27 x 161	1.38 x 16 CTRS.	28, 34, 40, 46, 51 (7D)	OT	E26	P19	232
A-640D-305-168	30,500	168, 141, 118	13.0	W27 x 146	1.38 x 16 CTRS.	28, 34, 40, 46, 51 (6D)	OT	E26	P19	232
A-640D-427-144	42,700	144, 120, 100	13.0	W27 x 161	1.38 x 16 CTRS.	28, 34, 40, 46, 51 (6D)	OT	E26	P19	232
A-640D-305-144	30,500	144, 120, 100	12.0	W27 x 146	1.25 x 12 CTRS.	28, 34, 40, 46, 51 (6D)	OT	E26	P18	326
A-640D-365-120	36,500	120, 100, 86	12.0	W27 x 146	1.25 x 12 CTRS.	28, 34, 40, 46, 51 (6D)	OT	E26	P18	326
A-456D-305-144	30,500	144, 120, 100	12.0	W27 x 146	1.25 x 12 CTRS.	28,34,40,46,51 (6D or 8C)	OT	E26	P18	326
A-456D-365-120	36,500	120, 100, 86	12.0	W27 x 146	1.25 x 12 CTRS.	28,34,40,46,51 (6D or 8C)	OT	E26	P18	326
A-456D-256-120	25,600	120, 104, 90	11.0	W24 x 104	1.25 x 12 CTRS.	28,34,40,46,51 (6D or 8C)	OT	E26	P18	324
A-320D-256-120	25,600	120, 104, 90	11.0	W24 x 104	1.25 x 12 CTRS.	25,30,36,42,47.25 (6Cor5D)	2T	E22	P18	324
A-320D-305-100	30,500	100, 86, 74	11.0	W24 x 104	1.25 x 12 CTRS.	25,30,36,42,47.25 (6Cor5D)	2T	E22	P18	324
A-228D-173-100	17,300	100, 86, 74	10.0	W21 x 101	1.13 x 12 CTRS.	24.25,30,36,41.25 (5C or 4D)	2T	E22	P17	322
A-228D-246-86	24,600	86, 74, 64	10.0	W21 x 101	1.13 x 12 CTRS.	24.25,30,36,41.25 (5C or 4D)	2T	E22	P17	322
A-160D-200-74	20,000	74, 64, 54	10.0	W18 x 76	1.13 x 12 CTRS.	24.25,29.25,33.25,38 (4Cor3D)	3TA	E19	P16	322
A-114D-173-64	17,300	64, 54	8.0	W16 x 67	1 x 9 CTRS.	19.25, 24, 33.25 (3C)	3TA	E18	P16	318

*Standard sheave sizes shown are floating hub sheaves for clutch driven compressors; largest size shown is maximum available. For units using electric motor driven compressors, select reducer sheaves from chart in the reducer section.

Counterbalance Data (effective counterbalance in pounds based on average pressure.)

Unit Size	Average Pressure,* PSIG											
	150	175	200	225	250	275	300	325	350	375	400	410
A-2560D-470-240												
A-1824D-470-240	–	2,870	5,740	8,610	11,480	14,350	17,220	20,090	22,960	25,830	28,700	29,850
A-1280D-470-240												
A-912D-470-240												
A-1824D-427-216												
A-1280D-427-216	920	3,220	5,520	7,820	10,120	12,420	14,720	17,020	19,320	21,620	23,920	24,830
A-912D-427-216												
A-1824D-427-192												
A-1280D-427-192	3,905	6,475	9,045	11,615	14,185	16,755	19,325	21,895	24,465	27,035	29,605	30,635
A-912D-427-192												
A-1280D-305-168												
A-912D-305-168	2,810	4,700	6,585	8,475	10,365	12,250	14,140	16,030	17,915	19,805	21,695	22,450
A-640D-305-168												
A-912D-427-144	5,240	7,420	9,605	11,785	13,970	16,150	18,335	20,515	22,700	24,880	27,065	27,935
A-640D-427-144												
A-640D-305-144	3,520	5,125	6,725	8,330	9,935	11,540	13,145	14,745	16,350	17,955	19,560	20,200
A-456D-305-144												
A-640D-365-120	4,725	6,630	8,535	10,440	12,345	14,250	16,155	18,060	19,965	21,870	23,775	24,535
A-456D-365-120												
A-456D-256-120	4,035	5,415	6,795	8,175	9,560	10,940	12,320	13,700	15,085	16,465	17,845	18,400
A-320D-256-120												
A-320D-305-100	4,855	6,495	8,135	9,775	11,415	13,055	14,695	16,335	17,975	19,615	21,255	21,910
A-228D-173-100	2,925	4,060	5,195	6,335	7,470	8,610	9,745	10,885	12,020	13,160	14,295	14,750
A-228D-246-86	4,045	5,355	6,670	7,980	9,295	10,605	11,920	13,230	14,545	15,855	17,170	17,695
A-160D-200-74	4,410	5,680	6,945	8,215	9,480	10,750	12,015	13,285	14,550	15,820	17,085	17,595
A-114D-173-64	2,760	3,550	4,345	5,135	5,930	6,720	7,515	8,305	9,100	9,890	10,685	11,000

* Pressure shown is average pressure between maximum and minimum and occurs at approximately beam horizontal position. For counterbalance at other pressures use direct interpolation.

LUFKIN

REVERSE MARK PUMPING UNITS



The Lufkin Reverse Mark or 'RM' Series Pumping Unit offers the customer an improved alternative to the conventional type geometry. Although similar in appearance to the Lufkin Conventional Pumping Unit, the RM unit geometry can reduce the torque and power requirements on many pumping applications. In some instances a smaller reducer and prime mover can be used.

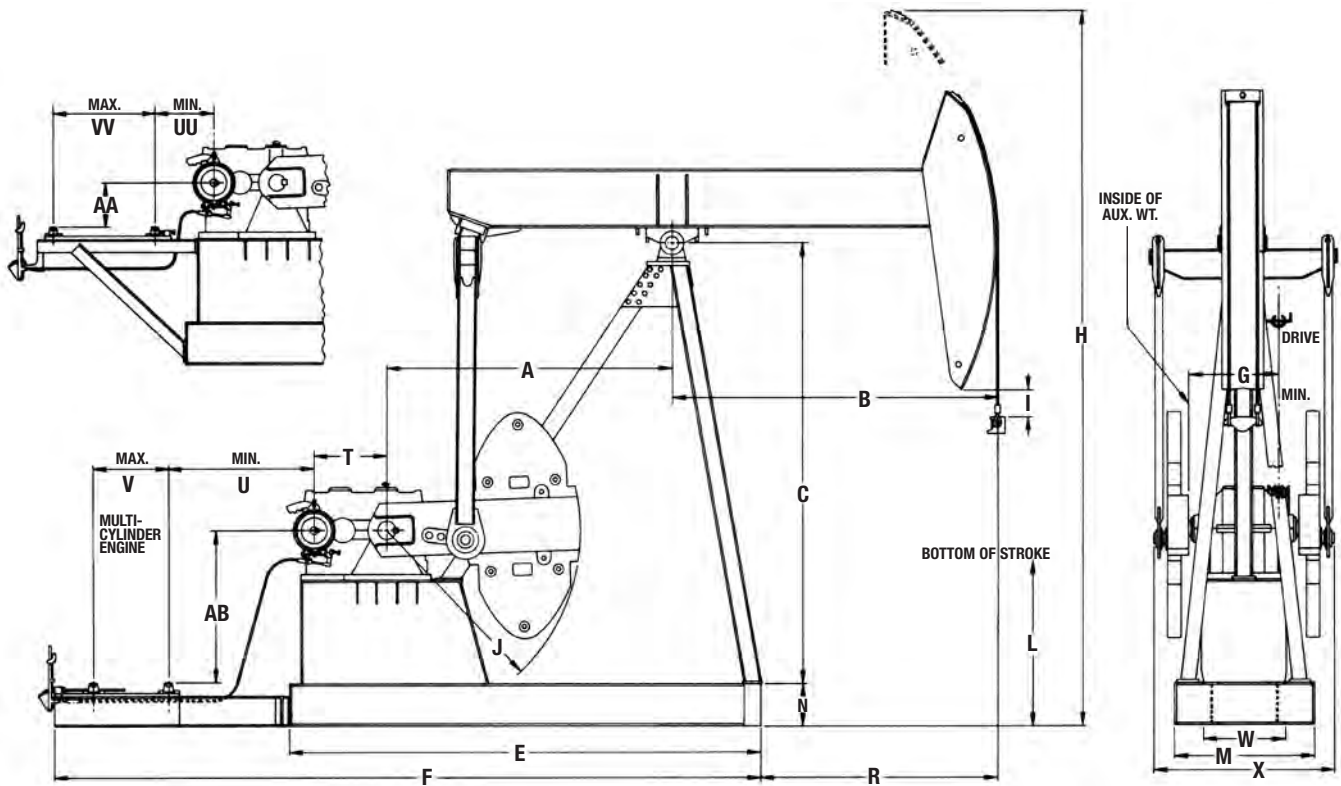

Dimensional Data (inches)

Unit Size	A	B	C	E	F	G	H	I	J	L	M	N	R	T	U	V	W	X	AA	AB	UU	VV
RM-1824D-427-192	163.00	228.50	253.00	277.50	410.50	61.63	446.00	19.00	110.00	52.38	86.00	21.00	179.00	58.88	83.00	52.00	50.00	106.00	51.75	90.88	12.50	57.00
RM-1824D-365-192	163.00	228.50	253.00	277.50	410.50	61.63	446.00	19.00	110.00	52.38	86.00	21.00	179.00	58.88	83.00	52.00	50.00	106.00	51.75	90.88	12.50	57.00
RM-1824D-427-168	163.00	200.00	253.00	277.50	410.50	61.63	425.00	35.38	110.00	60.13	86.00	21.00	150.50	58.88	83.00	52.00	50.00	106.00	51.75	90.88	12.50	57.00
RM-1824D-365-168	163.00	200.00	253.00	277.50	410.50	61.63	425.00	35.38	110.00	60.13	86.00	21.00	150.50	58.88	83.00	52.00	50.00	106.00	51.75	90.88	12.50	57.00
RM-1280D-427-192	163.00	228.50	253.50	289.50	410.50	58.75	458.35	18.50	110.00	52.13	88.00	21.00	179.00	52.50	83.00	52.00	50.00	109.50	51.69	90.88	34.50	52.75
RM-1280D-365-192	163.00	228.50	253.00	277.50	410.50	61.63	446.00	19.63	110.00	51.81	86.00	21.00	179.00	52.50	83.00	52.00	50.00	106.00	51.75	90.88	12.50	57.00
RM-1280D-427-168	163.00	200.00	253.00	277.50	410.50	61.63	425.00	35.38	110.00	60.13	86.00	21.00	150.50	52.50	83.00	52.00	50.00	106.00	51.75	90.88	12.50	57.00
RM-1280D-365-168	163.00	200.00	253.00	277.50	410.50	61.63	425.00	35.38	110.00	60.13	86.00	21.00	150.50	52.50	83.00	52.00	50.00	106.00	51.75	90.88	12.50	57.00
RM-912D-427-192	163.00	228.50	257.88	273.50	406.50	58.00	446.00	19.63	110.00	51.81	86.00	16.13	179.00	48.50	87.00	52.00	46.75	101.00	51.75	90.88	16.50	57.00
RM-912D-365-192	163.00	228.50	257.88	273.50	406.50	58.00	446.00	18.50	110.00	52.13	86.00	16.13	179.00	48.50	87.00	52.00	46.75	101.00	51.75	90.88	16.50	57.00
RM-912D-305-192	163.00	228.50	257.88	273.50	406.50	58.00	446.00	19.69	110.00	51.81	86.00	16.13	179.00	48.50	87.00	52.00	46.75	101.00	51.75	90.88	16.50	57.00
RM-912D-427-168	163.00	200.00	257.88	273.50	406.50	58.00	425.00	19.75	110.00	71.06	86.00	16.13	150.50	48.50	87.00	52.00	46.75	101.00	51.75	90.88	16.50	57.00
RM-912D-365-168	163.00	200.00	257.88	273.50	406.50	58.00	425.00	18.13	110.00	77.50	86.00	16.13	150.50	48.50	87.00	52.00	46.75	101.00	51.75	90.88	16.50	57.00
RM-912D-305-168	163.00	200.00	257.88	273.50	406.50	58.00	425.00	35.38	110.00	60.13	86.00	16.13	150.50	48.50	87.00	52.00	46.75	101.00	51.75	90.88	16.50	57.00
RM-912D-427-144	163.00	171.50	257.88	273.50	406.50	58.00	404.00	41.50	110.00	78.13	86.00	16.13	122.00	48.50	87.00	52.00	46.75	101.00	51.75	90.88	16.50	57.00
RM-912D-365-144	163.00	171.50	257.88	273.50	406.50	58.00	404.00	41.50	110.00	78.13	86.00	16.13	122.00	48.50	87.00	52.00	46.75	101.00	51.75	90.88	16.50	57.00
RM-912D-305-144	163.00	171.50	257.88	273.50	406.50	58.00	404.00	41.50	110.00	78.13	86.00	16.13	122.00	48.50	87.00	52.00	46.75	101.00	51.75	90.88	16.50	57.00
RM-640D-305-192	163.00	228.50	257.88	270.00	403.00	54.25	446.00	19.69	110.00	51.81	86.00	16.13	179.00	41.50	90.50	52.00	46.75	101.00	51.75	90.88	23.50	57.00
RM-640D-365-168	163.00	200.00	257.88	270.00	403.00	54.25	425.00	18.13	110.00	77.50	86.00	16.13	150.50	41.50	90.50	52.00	46.75	101.00	51.75	90.88	23.50	57.00
RM-640D-305-168	163.00	200.00	257.88	270.00	403.00	54.25	425.00	19.50	110.00	76.19	86.00	16.13	150.50	41.50	90.50	52.00	46.75	101.00	51.75	90.88	23.50	57.00
RM-640D-427-144	163.00	171.50	257.88	273.50	406.50	54.25	404.00	41.50	110.00	78.13	86.00	16.13	122.00	41.50	90.50	52.00	46.75	101.00	51.75	90.88	23.50	57.00

NOTE: Do not use above dimensions for foundation. Request foundation plan.
Popular API models shown, other models available on request.

REVERSE MARK PUMPING UNITS



Dimensional Data (inches)

Unit Size	A	B	C	E	F	G	H	I	J	L	M	N	R	T	U	V	W	X	AA	AB	UU	VV
RM-640D-365-144	163.00	171.50	257.88	270.00	403.00	54.25	404.00	34.63	110.00	85.00	86.00	16.13	122.00	41.50	90.50	52.00	46.75	101.00	51.75	90.88	23.50	57.00
RM-640D-305-144	163.00	171.50	257.88	270.00	403.00	54.25	404.00	34.63	110.00	85.00	86.00	16.13	122.00	41.50	90.50	52.00	46.75	101.00	51.75	90.88	23.50	57.00
RM-640D-256-144	163.00	171.50	257.88	270.00	403.00	54.25	404.00	41.50	110.00	78.13	86.00	16.13	122.00	41.50	90.50	52.00	46.75	101.00	51.75	90.88	23.50	57.00
RM-640D-305-120	142.00	144.50	222.00	241.00	359.00	54.25	346.00	38.38	95.00	69.38	70.00	15.88	103.00	41.50	76.00	52.00	46.75	98.50	51.75	75.88	26.75	37.75
RM-640D-256-120	142.00	144.50	222.00	241.00	359.00	54.25	346.00	38.38	95.00	69.38	70.00	15.88	103.00	41.50	76.00	52.00	46.75	98.50	51.75	75.88	26.75	37.75
RM-456D-305-168	142.00	202.00	222.00	241.00	359.00	51.38	388.00	19.38	95.00	40.13	76.00	15.88	160.50	38.38	79.00	52.00	46.75	98.50	51.75	75.88	26.13	37.75
RM-456D-365-144	142.00	173.00	222.00	241.00	359.00	51.38	368.00	23.50	95.00	60.13	76.00	15.88	131.50	38.38	79.00	52.00	46.75	98.50	51.75	75.88	26.13	37.75
RM-456D-305-144	142.00	173.00	222.00	241.00	359.00	51.38	368.00	23.50	95.00	60.13	76.00	15.88	131.50	38.38	79.00	52.00	46.75	98.50	51.75	75.88	26.13	37.75
RM-456D-256-144	142.00	173.00	222.00	241.00	365.00	52.30	377.60	12.77	95.00	70.84	76.00	15.90	131.50	38.40	82.00	53.00	46.80	97.50	53.50	78.88	30.50	32.25
RM-456D-365-120	142.00	144.50	222.00	241.00	359.00	51.38	346.00	38.38	95.00	69.38	70.00	15.88	103.00	38.38	79.00	52.00	46.75	98.50	51.75	75.88	26.13	37.75
RM-456D-305-120	142.00	144.50	222.00	241.00	359.00	51.38	346.00	38.38	95.00	69.38	70.00	15.88	103.00	38.38	79.00	52.00	46.75	98.50	51.75	75.88	26.13	37.75
RM-456D-256-120	142.00	144.50	222.00	241.00	359.00	51.38	346.00	38.38	95.00	69.38	70.00	15.88	103.00	38.38	79.00	52.00	46.75	98.50	51.75	75.88	26.13	37.75
RM-320D-256-144	142.00	173.00	222.00	235.50	359.50	44.75	368.00	13.50	95.00	70.00	70.00	15.88	131.50	34.00	83.50	53.00	43.00	85.50	54.00	79.00	31.00	33.25
RM-320D-305-120	142.00	144.50	222.00	235.50	359.50	44.75	346.00	38.38	95.00	69.38	70.00	15.88	103.00	34.00	83.50	53.00	43.00	85.50	54.00	79.00	31.00	33.25
RM-320D-256-120	142.00	144.50	222.00	235.50	359.50	44.75	346.00	36.63	95.00	71.19	70.00	15.88	103.00	34.00	83.50	53.00	43.00	85.50	54.00	79.00	31.00	33.25
RM-320D-213-120	142.00	144.50	222.00	235.50	359.50	44.75	346.00	36.31	95.00	71.00	70.00	15.88	103.00	34.00	83.50	53.00	43.00	85.50	54.00	79.00	31.00	33.25
RM-320D-305-100	142.00	120.50	222.00	235.50	359.50	44.75	328.00	59.00	95.00	69.38	70.00	15.88	79.00	34.00	83.50	53.00	43.00	85.50	54.00	79.00	31.00	33.25
RM-320D-256-100	142.00	120.50	222.00	235.50	359.50	44.75	328.00	36.44	95.00	91.38	70.00	15.88	79.00	34.00	83.50	53.00	43.00	85.50	54.00	79.00	31.00	33.25
RM-320D-246-86	127.00	103.50	190.13	216.50	323.50	44.75	283.00	36.88	78.00	73.63	70.00	15.88	62.00	34.00	66.50	53.00	43.00	85.50	37.13	62.13	30.00	33.25
RM-228D-213-120	142.00	144.50	222.00	228.50	359.00	38.63	346.00	38.38	95.00	69.38	70.00	15.88	103.00	30.00	87.00	53.00	37.00	78.50	54.00	79.00	28.00	33.25
RM-228D-256-100	142.00	120.50	222.00	228.50	359.00	38.63	328.00	36.75	95.00	91.50	70.00	15.88	79.00	30.00	87.00	53.00	37.00	78.50	54.00	79.00	28.00	33.25
RM-228D-213-100	127.00	120.00	190.13	209.50	323.00	39.13	295.00	23.00	78.00	73.75	70.00	15.88	78.50	30.00	70.00	53.00	37.00	78.50	37.13	62.13	27.88	33.25
RM-228D-173-100	127.00	120.00	190.13	209.50	323.00	39.13	295.00	23.00	78.00	73.75	70.00	15.88	78.50	30.00	70.00	53.00	37.00	78.50	37.13	62.13	27.88	33.25
RM-228D-246-86	127.00	103.50	190.13	209.50	323.00	39.13	283.00	36.88	78.00	73.63	70.00	15.88	62.00	30.00	70.00	53.00	37.00	78.50	37.13	62.13	27.88	33.25
RM-228D-213-86	127.00	103.50	190.13	209.50	323.00	39.13	283.00	36.88	78.00	73.63	70.00	15.88	62.00	30.00	70.00	53.00	37.00	78.50	37.13	62.13	27.88	33.25
RM-228D-200-74	127.00	89.00	190.13	209.50	323.00	39.13	273.00	46.88	78.00	77.63	70.00	15.88	47.50	30.00	70.00	53.00	37.00	78.50	37.13	62.13	27.88	33.25
RM-228D-173-74	127.00	89.00	190.13	209.50	323.00	39.13	273.00	46.88	78.00	77.63	70.00	15.88	47.50	30.00	70.00	53.00	37.00	78.50	37.13	62.13	27.88	33.25

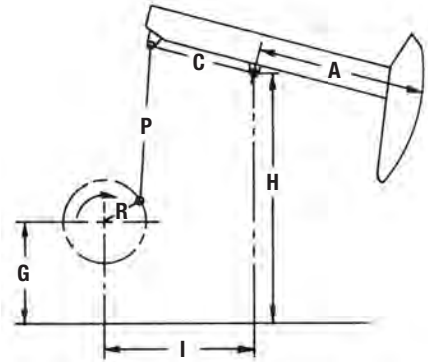

API Geometry Dimensions (inches)

Unit Size	A	C	P	I	H	G	R1, R2, R3	PHASE ANGLE	T.F. @ (90°-Phase Angle)	S.U.* (Est.)
RM-1824D-427-192	228.5	118	171.0	163	274.00	111.00	45, 38, 31	-9.0	86.11	-1650
RM-1824D-365-192	228.5	118	171.0	163	274.00	111.00	45, 38, 31	-9.0	86.11	-1650
RM-1824D-427-168	200.0	118	171.0	163	274.00	111.00	45, 38, 31	-9.0	75.37	-515
RM-1824D-365-168	200.0	118	171.0	163	274.00	111.00	45, 38, 31	-9.0	75.37	-515
RM-1280D-427-192	228.5	118	171.0	163	274.50	111.00	45, 38, 31	-9.0	86.10	-1,395
RM-1280D-365-192	228.5	118	171.0	163	274.50	111.00	45, 38, 31	-9.0	86.10	-1460
RM-1280D-427-168	200.0	118	171.0	163	274.00	111.00	45, 38, 31	-9.0	75.37	-515
RM-1280D-365-168	200.0	118	171.0	163	274.00	111.00	45, 38, 31	-9.0	75.37	-515
RM-912D-427-192	228.5	118	171.0	163	274.00	111.00	45, 38, 31	-12.0	85.34	-1555
RM-912D-365-192	228.5	118	171.0	163	274.50	111.00	45, 38, 31	-12.0	85.35	-1530
RM-912D-305-192	228.5	118	171.0	163	274.00	111.00	45, 38, 31	-9.0	86.11	-1735
RM-912D-427-168	200.0	118	171.0	163	274.50	111.00	45, 38, 31	-12.0	74.70	-490
RM-912D-365-168	200.0	118	171.0	163	274.00	111.00	45, 38, 31	-9.0	75.37	-905
RM-912D-305-168	200.0	118	171.0	163	274.00	111.00	45, 38, 31	-9.0	75.36	-1045
RM-912D-427-144	171.5	118	171.0	163	274.00	111.00	45, 38, 31	-9.0	64.63	630
RM-912D-365-144	171.5	118	171.0	163	274.00	111.00	45, 38, 31	-9.0	64.63	50
RM-912D-305-144	171.5	118	171.0	163	274.00	111.00	45, 38, 31	-9.0	64.63	50
RM-640D-305-192	228.5	118	171.0	163	274.00	111.00	45, 38, 31	-12.0	85.35	-1745
RM-640D-365-168	200.0	118	171.0	163	274.00	111.00	45, 38, 31	-12.0	74.70	-910
RM-640D-305-168	200.0	118	171.0	163	274.00	111.00	45, 38, 31	-9.0	75.36	-1045
RM-640D-427-144	171.5	118	171.0	163	274.00	111.00	45, 38, 31	-12.0	64.06	630
RM-640D-365-144	171.5	118	171.0	163	274.00	111.00	45, 38, 31	-9.0	64.62	-25
RM-640D-305-144	171.5	118	171.0	163	274.00	111.00	45, 38, 31	-9.0	64.62	30
RM-640D-256-144	171.5	118	171.0	163	274.00	111.00	45, 38, 31	-9.0	64.63	-140
RM-640D-305-120	144.5	103	149.0	142	237.88	96.00	39, 33, 27	-12.5	53.50	335
RM-640D-256-120	144.5	103	149.0	142	237.88	96.00	39, 33, 27	-12.5	53.50	235
RM-456D-305-168	202.0	103	149.0	142	237.88	96.00	39, 33, 27	-14.0	74.40	-1580
RM-456D-365-144	173.0	103	149.0	142	237.88	96.00	39, 33, 27	-14.0	63.72	-765
RM-456D-305-144	173.0	103	149.0	142	237.88	96.00	39, 33, 27	-12.5	64.05	-700
RM-456D-256-144	173.0	103	149.0	142	237.80	95.80	39, 33, 27	-14.0	63.72	-975
RM-456D-365-120	144.5	103	149.0	142	237.88	96.00	39, 33, 27	-12.5	53.50	680
RM-456D-305-120	144.5	103	149.0	142	237.88	96.00	39, 33, 27	-12.5	53.50	335
RM-456D-256-120	144.5	103	149.0	142	237.88	96.00	39, 33, 27	-12.5	53.50	235
RM-320D-256-144	173.0	103	149.0	142	237.88	95.88	39, 33, 27	-14.0	63.71	-1075
RM-320D-305-120	144.5	103	149.0	142	237.88	96.00	39, 33, 27	-14.0	53.22	335
RM-320D-256-120	144.5	103	148.5	142	237.88	95.88	39, 33, 27	-12.5	53.50	45
RM-320D-213-120	144.5	103	149.0	142	237.88	95.88	39, 33, 27	-12.5	53.51	45
RM-320D-305-100	120.5	103	149.0	142	237.88	96.00	39, 33, 27	-12.5	44.61	600
RM-320D-256-100	120.5	103	148.5	142	237.88	95.88	39, 33, 27	-12.5	44.62	750
RM-320D-246-86	103.5	92	134.0	127	206.00	79.00	35, 30, 25	-14.0	38.29	720
RM-228D-213-120	144.5	103	149.0	142	237.88	96.00	39, 33, 27	-14.0	53.22	40
RM-228D-256-100	120.5	103	148.5	142	237.88	96.00	39, 33, 27	-14.0	44.39	740
RM-228D-213-100	120.0	92	134.0	127	206.00	79.00	35, 30, 25	-14.0	44.39	90
RM-228D-173-100	120.0	92	134.0	127	206.00	79.00	35, 30, 25	-14.0	44.39	90
RM-228D-246-86	103.5	92	134.0	127	206.00	79.00	35, 30, 25	-14.0	38.29	655
RM-228D-213-86	103.5	92	134.0	127	206.00	79.00	35, 30, 25	-14.0	38.29	340
RM-228D-200-74	89.0	92	134.0	127	206.00	79.00	35, 30, 25	-14.0	32.93	680
RM-228D-173-74	89.0	92	134.0	127	206.00	79.00	35, 30, 25	-14.0	32.93	680

*Structural Unbalance in pounds.

REVERSE MARK PUMPING UNITS

The design for the “improved geometry class one lever system” (Reverse Mark pumping unit) was included in the original patent awarded to Joe Byrd for the Mark II pumping unit.

Structural Data

Unit Size	Polished Rod Capacity (lbs.)	Stroke Lengths (inches)	Walking Beam	Wireline Hanger (inches)	Cranks	Crank Pin Bearing	Equalizer Bearing	Center Bearing
RM-1824D-427-192	42,700	192, 158, 127	W36 x 262	1-3/8 x 16 CTRS.	90110 RMA	OS	00R	00TG
RM-1280D-427-192	42,700	192, 158, 127	W36 x 262	1-3/8 x 16 CTRS.	90110 RMA	OS	00R	00TG
RM-912D-427-192	42,700	192, 158, 127	W36 x 262	1-3/8 x 16 CTRS.	90110 RMA	OS	00R	00TG
RM-1824D-365-192	36,500	192, 158, 127	W36 x 247	1-3/8 x 16 CTRS.	90110 RMA	OS	00R	0TGB
RM-1280D-365-192	36,500	192, 158, 127	W36 x 247	1-3/8 x 16 CTRS.	90110 RMA	OS	00R	00TG
RM-912D-365-192	36,500	192, 158, 127	W36 x 247	1-3/8 x 16 CTRS.	90110 RMA	OS	00R	00TG
RM-912D-305-192	30,500	192, 158, 127	W33 x 221	1-3/8 x 16 CTRS.	90110 RMA	1SE	00R	0TGB
RM-640D-305-192	30,500	192, 158, 127	W33 x 221	1-3/8 x 16 CTRS.	90110 RMA	1SE	00R	0TGB
RM-1824D-427-168	42,700	168, 139, 111	W36 x 247	1-3/8 x 16 CTRS.	90110 RMA	OS	00R	0TGB
RM-1280D-427-168	42,700	168, 139, 111	W36 x 247	1-3/8 x 16 CTRS.	90110 RMA	OS	00R	0TGB
RM-912D-427-168	42,700	168, 139, 111	W36 x 247	1-3/8 x 16 CTRS.	90110 RMA	OS	00R	00TG
RM-1824D-365-168	36,500	168, 139, 111	W33 x 221	1-3/8 x 16 CTRS.	90110 RMA	1SE	00R	0TGB
RM-1280D-365-168	36,500	168, 139, 111	W33 x 221	1-3/8 x 16 CTRS.	90110 RMA	1SE	00R	0TGB
RM-912D-365-168	36,500	168, 139, 111	W33 x 221	1-3/8 x 16 CTRS.	90110 RMA	1SE	00R	0TGB
RM-640D-365-168	36,500	168, 139, 111	W33 x 221	1-3/8 x 16 CTRS.	90110 RMA	1SE	00R	0TGB
RM-912D-305-168	30,500	168, 139, 111	W33 x 201	1-1/4 x 16 CTRS.	90110 RMA	1SE	ORA	0TGB
RM-640D-305-168	30,500	168, 139, 111	W33 x 201	1-1/4 x 16 CTRS.	90110 RMA	1SE	ORA	0TGB
RM-456D-305-168	30,500	168, 139, 112	W33 x 201	1-1/4 x 16 CTRS.	7895 RM	1SE	ORA	0TGB
RM-912D-427-144	42,700	144, 119, 95	W33 x 201	1-3/8 x 16 CTRS.	90110 RMA	1SE	00R	0TGB
RM-640D-427-144	42,700	144, 119, 95	W33 x 201	1-3/8 x 16 CTRS.	90110 RMA	1SE	00R	0TGB
RM-912D-365-144	36,500	144, 119, 95	W33 x 201	1-3/8 x 16 CTRS.	90110 RMA	1SE	ORA	0TGB
RM-640D-365-144	36,500	144, 119, 95	W33 x 201	1-3/8 x 16 CTRS.	90110 RMA	1SE	ORA	0TGB
RM-456D-365-144	36,500	144, 119, 96	W33 x 201	1-3/8 x 16 CTRS.	7895 RM	1SE	ORA	0TGB
RM-912D-305-144	30,500	144, 119, 95	W30 x 173	1-1/4 x 16 CTRS.	90110 RMA	1SE	ORA	0TGB
RM-640D-305-144	30,500	144, 119, 95	W30 x 173	1-1/4 x 16 CTRS.	90110 RMA	1SE	ORA	0TGB
RM-456D-305-144	30,500	144, 119, 96	W30 x 173	1-1/4 x 16 CTRS.	7895 RM	1SE	ORA	0TGB
RM-640D-256-144	25,600	144, 119, 95	W30 x 173	1-1/4 x 16 CTRS.	90110 RMA	1SE	ORA	0TGB
RM-456D-256-144	25,600	144, 119, 96	W30 x 173	1-1/4 x 16 CTRS.	7895 RM	2SE	ORA	1TGC
RM-320D-256-144	25,600	144, 119, 96	W30 x 173	1-1/4 x 16 CTRS.	7895 RM	2SE	ORA	1TGC
RM-456D-365-120	36,500	120, 100, 80	W30 x 173	1-3/8 x 12 CTRS.	7895 RM	1SE	ORA	0TGB
RM-640D-305-120	30,500	120, 100, 80	W27 x 146	1-1/4 x 12 CTRS.	7895 RM	2SE	ORA	1TGC
RM-456D-305-120	30,500	120, 100, 80	W27 x 146	1-1/4 x 12 CTRS.	7895 RM	2SE	ORA	1TGC
RM-320D-305-120	30,500	120, 100, 80	W27 x 146	1-1/4 x 12 CTRS.	7895 RM	2SE	ORA	1TGC
RM-640D-256-120	25,600	120, 100, 80	W27 x 146	1-1/8 x 12 CTRS.	7895 RM	2SE	1RA	1TGC
RM-456D-256-120	25,600	120, 100, 80	W27 x 146	1-1/8 x 12 CTRS.	7895 RM	2SE	1RA	1TGC
RM-320D-256-120	25,600	120, 100, 80	W27 x 146	1-1/8 x 12 CTRS.	7895 RM	2SE	1RA	1TGC
RM-320D-213-120	21,300	120, 100, 80	W27 x 146	1-1/8 x 12 CTRS.	7895 RM	2SE	2RB	2TGC
RM-228D-213-120	21,300	120, 100, 80	W27 x 146	1-1/8 x 12 CTRS.	7895 RM	2SE	2RB	2TGC
RM-320D-305-100	30,500	100, 83, 67	W27 x 146	1-1/4 x 12 CTRS.	7895 RM	2SE	1RA	1TGC
RM-320D-256-100	25,600	100, 83, 67	W27 x 146	1-1/8 x 12 CTRS.	7895 RM	2SE	2RB	2TGC
RM-228D-256-100	25,600	100, 83, 67	W27 x 146	1-1/8 x 12 CTRS.	7895 RM	2SE	2RB	2TGC
RM-228D-213-100	21,300	100, 84, 69	W24 x 117	1-1/8 x 12 CTRS.	7078 RM	3SF	2RB	2TGC
RM-228D-173-100	17,300	100, 84, 69	W24 x 104	1-1/8 x 12 CTRS.	7078 RM	3SF	2RB	4TG
RM-320D-246-86	24,600	86, 72, 59	W24 x 117	1-1/8 x 12 CTRS.	7078 RM	3SF	2RB	2TGC
RM-228D-246-86	24,600	86, 72, 59	W24 x 117	1-1/8 x 12 CTRS.	7078 RM	3SF	2RB	2TGC
RM-228D-213-86	21,300	86, 72, 59	W24 x 104	1-1/8 x 12 CTRS.	7078 RM	3SF	2RB	2TGC
RM-228D-200-74	20,000	74, 62, 51	W24 x 94	1 x 9 CTRS.	7078 RM	5SA	3RA	4TG
RM-228D-173-74	17,300	74, 62, 51	W24 x 84	1 x 9 CTRS.	7078 RM	5SA	3RA	4TG

Counterbalance Data (shown in lbs., effective at polished rod with weights at maximum position, including structural unbalance.)

Unit Size	RM-1824D-427-192 RM-1280D-427-192	RM-1824D-365-192 RM-1280D-365-192	RM-912D-427-192	RM-912D-365-192	RM-912D-305-192	RM-640D-305-192
Maximum Stroke	192"	192"	192"	192"	192"	192"
Structural Unbalance	-1395 lbs.	-1460 lbs.	-1555 lbs.	-1530 lbs.	-1735 lbs.	-1745 lbs.
Cranks	9011ORMA	9011ORMA	9011ORMA	9011ORMA	9011ORMA	9011ORMA
C'Bal., Cranks Only	4,980	4,915	4,880	4,905	4,640	4,690
4 No. OORO Counterweights	18,890	18,825	18,915	18,935	18,550	18,720
4 No. OOS Aux. Weights	23,085	23,020	23,150	23,170	22,745	22,955
8 No. OOS Aux. Weights	27,280	27,215	27,385	27,405	26,940	27,190
4 No. ORO Counterweights	17,115	17,050	17,125	17,145	16,775	16,930
4 No. OS Aux. Weights	21,145	21,080	21,190	21,210	20,805	20,995
8 No. OS Aux. Weights	25,175	25,110	25,255	25,275	24,835	25,060
4 No. OARO Counterweights	15,220	15,155	15,210	15,235	14,880	15,020
4 No. OAS Aux. Weights	18,390	18,325	18,410	18,435	18,050	18,220
8 No. OAS Aux. Weights	21,560	21,495	21,610	21,635	21,220	21,420
4 No. 1RO Counterweights	12,945	12,880	12,915	12,940	12,605	12,725
4 No. 1S Aux. Weights	15,395	15,330	15,385	15,410	15,055	15,195
8 No. 1S Aux. Weights	17,845	17,780	17,855	17,880	17,505	17,665
4 No. 2RO Counterweights	11,605	11,540	11,560	11,585	11,260	11,370
4 No. 2S Aux. Weights	13,980	13,915	13,955	13,980	13,635	13,765
8 No. 2S Aux. Weights	16,355	16,290	16,350	16,375	16,010	16,160
4 No. 3CRO Counterweights	10,315	10,250	10,260	10,285	9,875	10,070
4 No. 3BS Aux. Weights	12,615	12,550	12,580	12,605	12,275	12,390
8 No. 3BS Aux. Weights	14,915	14,850	14,900*	14,925	14,575	14,710
4 No. 5ARO Counterweights	8,845	8,780	8,780	8,800	8,505	8,585
4 No. 5A Aux. Weights	10,395	10,330	10,340	10,360	10,055	10,145
8 No. 5A Aux. Weights	11,945	11,880	11,900*	11,920	11,605	11,705
4 No. 5CRO Counterweights	7,820	7,755	7,745	7,770	7,475	7,555
4 No. 5CS Aux. Weights	9,220	9,155	9,160	9,185	8,875	8,970
8 No. 5CS Aux. Weights	10,620	10,555	10,575	10,600	10,275	10,385
4 No. 6RO Counterweights	7,175	7,110	7,095	7,120	6,835	6,905
4 No. 6 Aux. Weights	8,000	7,935	7,930	7,955	7,660	7,740
8 No. 6 Aux. Weights	8,825	8,760	8,765	8,790	8,485	8,575
4 No. 7RO Counterweights	6,375	6,310	6,290	6,315	6,035	6,100
4 No. 7 Aux. Weights	6,995	6,930	6,915	6,940	6,655	6,725
8 No. 7 Aux. Weights	7,615	7,550	7,540	7,565	7,275	7,350

Unit Size	RM-912D-365-144 RM-640D-365-144	RM-912D-305-144 RM-640D-305-144	RM-456D-365-144	RM-456D-305-144	RM-640D-256-144	RM-456D-256-144
Maximum Stroke	144"	144"	144"	144"	144"	144"
Structural Unbalance	-25 lbs.	30 lbs.	-765 lbs.	-700 lbs.	-140 lbs.	-975 lbs.
Cranks	9011ORMA	9011ORMA	7895RM	7895RM	9011ORMA	7895 RM
C'Bal., Cranks Only	8,470	8,525	5,540	5,575	8,355	5,330
4 No. OORO Counterweights	-	-	-	-	-	-
4 No. OOS Aux. Weights	-	-	-	-	-	-
8 No. OOS Aux. Weights	-	-	-	-	-	-
4 No. ORO Counterweights	24,640	24,695	18,610	18,575	24,445	18,425
4 No. OS Aux. Weights	30,010	30,065	22,950	22,890	-	22,775
8 No. OS Aux. Weights	35,380	-	27,290	27,205	-	-
4 No. OARO Counterweights	22,115	22,170	16,755	16,730	21,975	16,545
4 No. OAS Aux. Weights	26,340	26,395	20,225	20,185	-	20,020
8 No. OAS Aux. Weights	30,565	-	23,695	23,640	-	-
4 No. 1RO Counterweights	19,085	19,140	14,290	14,280	18,950	14,080
4 No. 1S Aux. Weights	22,350	22,405	16,980	16,955	22,210	16,770
8 No. 1S Aux. Weights	25,615	25,670	19,670	19,630	25,470	19,460
4 No. 2RO Counterweights	17,295	17,350	12,830	12,825	17,810	12,620
4 No. 2S Aux. Weights	20,455	20,510	15,440	15,425	20,340	15,230
8 No. 2S Aux. Weights	23,615	23,670	18,050	18,025	23,500	17,840
4 No. 3CRO Counterweights	15,575	15,630	11,455	11,460	15,460	11,250
4 No. 3BS Aux. Weights	18,640	18,695	14,005	13,995	18,525	13,800
8 No. 3BS Aux. Weights	21,705*	21,760*	16,555	16,530	21,590	16,350
4 No. 5ARO Counterweights	13,615	13,670	9,870	9,880	13,500	9,665
4 No. 5A Aux. Weights	15,680	15,735	11,605	11,605	15,560	11,400
8 No. 5A Aux. Weights	17,745*	17,800*	13,340	13,330	17,620	13,135
4 No. 5CRO Counterweights	12,250	12,305	8,730	8,745	12,135	8,520
4 No. 5CS Aux. Weights	14,120	14,175	10,305	10,310	14,000	10,095
8 No. 5CS Aux. Weights	15,990	16,045	11,880	11,875	15,865	11,670
4 No. 6RO Counterweights	11,395	11,450	8,015	8,040	-	7,795
4 No. 6 Aux. Weights	12,495	12,550	8,950	8,970	-	8,725
8 No. 6 Aux. Weights	13,595	13,650	9,885	9,900	-	9,655
4 No. 7RO Counterweights	10,330	10,385	7,120	7,145	-	6,905
4 No. 7 Aux. Weights	11,155	11,210	7,820	7,845	-	7,605
8 No. 7 Aux. Weights	11,980	12,035	8,520	8,545	-	8,305

* Use only one Aux. weight per counterweight on belt cover side on 912D and 320D units. ** Use only one Aux. weight per counterweight on belt cover side on 228D units.

REVERSE MARK PUMPING UNITS



RM-1824D-427-168
RM-1280D-427-168
RM-1824D-365-168
RM-1280D-365-168
RM-912D-365-168

RM-912D-427-168

RM-640D-365-168

RM-912D-305-168
RM-640D-305-168

RM-456D-305-168

RM-912D-427-144

RM-640D-427-144

168" -905 lbs.	168" -490 lbs.	168" -910 lbs.	168" -1045 lbs.	168" -1580 lbs.	144" 630 lbs.	144" 630 lbs.
9011ORMA	9011ORMA	9011ORMA	9011ORMA	7895RM	9011ORMA	9011ORM
6,380	6,860	6,440	6,240	3,820	9,125	9,200
22,270	22,895	-	-	-	27,565	27,805
27,065	27,735	-	-	-	33,130	33,420
31,860	32,575	-	-	-	38,695	39,035
20,240	20,845	20,425	20,105	15,010	25,215	25,430
24,845	25,490	25,070	24,710	18,725	30,555	30,820
29,450	30,135	29,715	29,315	22,440	35,895	36,210
18,080	18,665	18,245	17,940	13,425	22,745	22,945
21,700	22,320	21,900	21,565	16,400	26,965	27,200
25,320	25,975	25,555	25,190	19,375	31,185	31,455
15,480	16,040	15,620	15,340	11,310	19,270	19,890
18,280	18,865	18,445	18,140	13,615	22,980	23,175
21,080	21,690	21,270	20,940	15,920	26,240	26,460
13,945	14,495	14,075	13,805	10,060	17,950	18,100
16,655	17,230	16,810	16,515	12,295	21,110	21,290
19,365	19,965	19,545	19,225	14,530	24,270	24,480
12,475	13,010	12,590	12,335	8,890	16,230	16,370
15,100	15,660	15,240	14,960	11,075	19,295	19,460
17,725	18,310	17,890	17,585*	13,260	22,360*	22,550
10,795	11,315	10,895	10,655	7,530	14,270	14,390
12,565	13,100	12,680	12,425	9,015	16,330	16,470
14,335	14,885	14,465	14,195*	10,500	18,390*	18,550
9,620	10,130	9,710	9,480	6,550	12,905	13,010
11,220	11,745	11,325	11,080	7,900	14,770	14,895
12,820	13,360	12,940	12,680	9,250	16,635	16,780
8,885	9,390	8,970	8,745	5,940	-	-
9,830	10,345	9,925	9,690	6,740	-	-
10,775	11,300	10,880	10,635	7,540	-	-
7,975	8,470	8,050	7,835	5,175	-	-
8,685	9,185	8,765	8,545	5,775	-	-
9,395	9,900	9,480	9,255	6,375	-	-

RM-320D-256-144	RM-456D-365-120	RM-640D-305-120 RM-456D-305-120	RM-320D-305-120	RM-640D-256-120 RM-456D-256-120 RM-320D-256-120	RM-320D-213-120	RM-228D-213-120
144" -1075 lbs.	120" 680 lbs.	120" 335 lbs.	120" 335 lbs.	120" 45 lbs.	120" -45 lbs.	120" 40 lbs.
7895RM	7895RM	7895RM	7895RM	7895RM	7895RM	7895RM
5,230	8,190	7,845	7,885	7,555	7,465	7,590
-	-	-	-	-	-	-
-	-	-	7,885	-	-	-
18,235	23,755	23,410	23,530	23,150	-	-
22,675	28,925	28,580	28,725	-	-	-
-	34,095	-	-	-	-	-
16,445	21,545	21,200	21,310	20,910	20,820	-
19,920	25,680	25,335	25,465	25,045	-	-
23,395	29,815	-	-	-	-	-
13,980	18,610	18,265	18,360	17,975	17,880	18,065
16,670	21,815	21,470	21,580	21,180	21,085	-
19,360	25,020	24,675	24,800	24,385	-	-
12,520	16,870	16,525	16,610	16,235	16,145	16,315
15,130	19,980	19,635	19,735	19,345	19,255	19,440
17,740	23,090	22,745	22,860	22,455	-	-
11,150	15,235	14,890	14,970	14,600	14,510	14,675
13,700	18,275	17,930	18,025	17,640	17,545	17,730
16,250	21,315	20,970	21,080*	20,680*	20,580*	20,785**
9,565	13,345	13,000	13,070	12,715	12,625	12,775
11,300	15,410	15,065	15,150	14,785	14,695	14,855
13,035	17,475	17,130	17,230*	16,855*	16,765*	16,935
8,420	11,990	11,645	11,705	11,355	11,265	11,410
9,995	13,865	13,520	13,590	13,230	13,140	13,295
11,570	15,740	15,395	15,475	15,105	15,015	15,180
7,695	11,140	10,795	10,850	10,495	10,405	10,555
8,625	12,250	11,905	11,970	11,605	11,510	11,675
9,555	13,360	13,015	13,090	12,715	12,615	12,795
6,805	10,070	9,725	9,775	9,430	9,340	9,480
7,505	10,905	10,560	10,615	10,265	10,175	10,320
8,205	11,740	11,395	11,455	11,100	11,010	11,160

Counterbalance Data (shown in lbs., effective at polished rod with weights at maximum position, including structural unbalance.)

Unit Size	RM-320D-305-100 RM-320D-256-100	RM-228D-256-100	RM-228D-213-100 RM-228D-173-100	RM-320D-246-86 RM-228D-246-86	RM-228D-213-86	RM-228D-200-74 RM-228D-173-74
Maximum Stroke	100"	100"	100"	86"	86"	74"
Structural Unbalance	750 lbs.	740 lbs.	90 lbs.	655 lbs.	340 lbs.	680 lbs.
Cranks	7895RM	7078RM	7078RM	7078RM	7078RM	7078RM
C'Bal., Cranks Only	9,755	9,790	4,670	5,695	5,650	6,855
4 No. OORO Counterweights	-	-	-	-	-	-
4 No. OOS Aux. Weights	-	-	-	-	-	-
8 No. OOS Aux. Weights	-	-	-	-	-	-
4 No. ORO Counterweights	-	-	-	-	-	-
4 No. OS Aux. Weights	-	-	-	-	-	-
8 No. OS Aux. Weights	-	-	-	-	-	-
4 No. OARO Counterweights	-	-	-	-	-	-
4 No. OAS Aux. Weights	-	-	-	-	-	-
8 No. OAS Aux. Weights	-	-	-	-	-	-
4 No. 1RO Counterweights	22,250	22,350	-	-	-	-
4 No. 1S Aux. Weights	-	-	-	-	-	-
8 No. 1S Aux. Weights	-	-	-	-	-	-
4 No. 2RO Counterweights	20,160	20,250	12,595	15,150	14,835	17,535
4 No. 2S Aux. Weights	23,890	24,000	15,435	18,440	18,125	-
8 No. 2S Aux. Weights	-	-	18,275	21,730	-	-
4 No. 3CRO Counterweights	18,205	18,285	11,195	13,525	13,210	15,645
4 No. 3BS Aux. Weights	21,845	21,945	14,005	16,785	16,470	-
8 No. 3BS Aux. Weights	25,485	-	16,815	20,045	19,730	-
4 No. 5ARO Counterweights	15,945	16,010	9,530	11,605	11,285	13,405
4 No. 5A Aux. Weights	18,425	18,505	11,475	13,865	13,540	16,030
8 No. 5A Aux. Weights	20,905*	21,000	13,425	16,125*	15,800	-
4 No. 5CRO Counterweights	14,310	14,370	8,265	10,135	9,815	11,700
4 No. 5CS Aux. Weights	16,560	16,630	10,040	12,195	11,875	14,095
8 No. 5CS Aux. Weights	18,810	18,890	11,815	14,255*	13,930	16,485
4 No. 6RO Counterweights	13,280	13,330	7,475	9,215	8,905	10,640
4 No. 6 Aux. Weights	14,610	14,665	8,535	10,440	10,130	12,065
8 No. 6 Aux. Weights	15,940	16,000	9,595	11,665	11,355	13,490
4 No. 7RO Counterweights	12,005	12,050	6,470	8,050	7,740	9,280
4 No. 7 Aux. Weights	13,005	13,055	7,270	8,980	8,665	10,360
8 No. 7 Aux. Weights	14,005	14,060	8,070	9,910	9,595	11,440

*Use only one Aux. weight per counterweight on belt cover side on 320D units. ** Use only one Aux. weight per counterweight on belt cover side on 228D units.

LUFKIN

CHURCHILL® BRAND BEAM BALANCED PUMPING UNITS



Churchill Beam Balanced Pumping Units, available exclusively from Lufkin Industries, have been field proven since 1954. They offer the same rugged dependability as our conventional units. On shallow wells around the world, they have long been the producer's unit of choice.

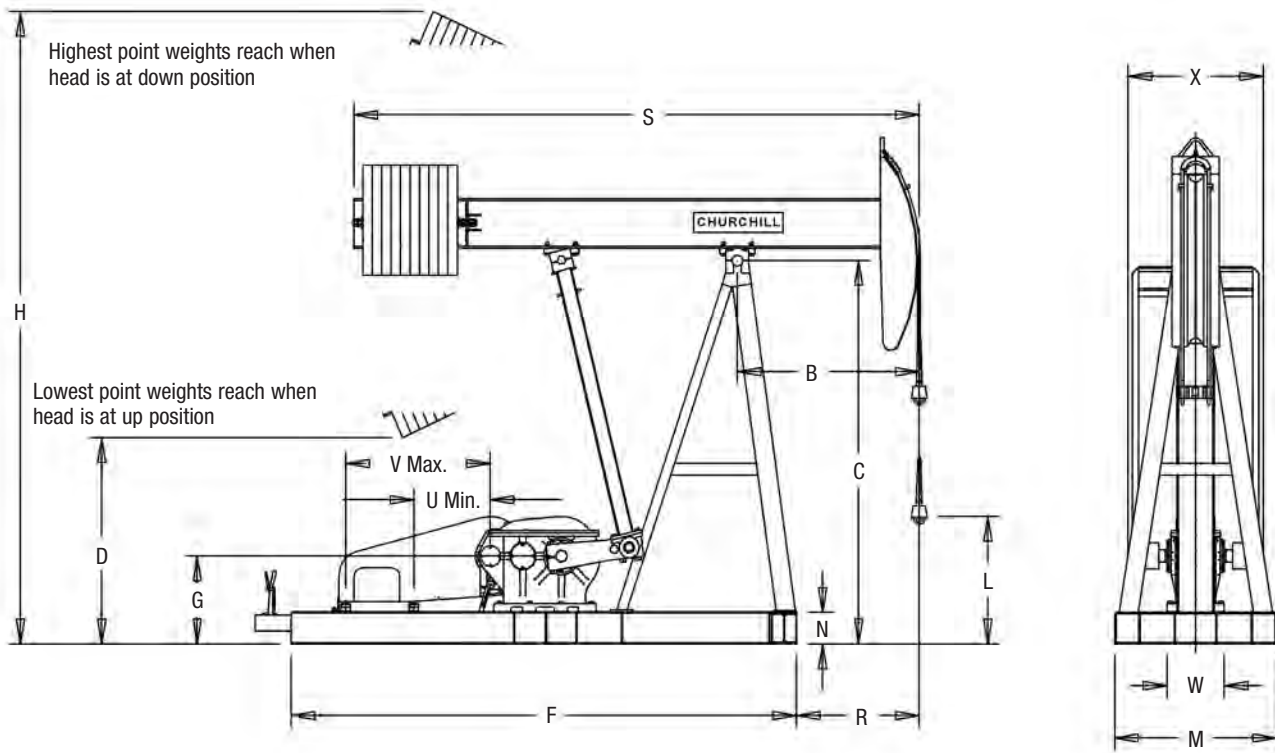

Dimensional Data (inches)

Unit Size	B	C	D	F	G	H	L	M	N	R	S	U	V	W	X
B-114-119-100	109.00	152.0	92.25	174.38	28.75	231.5	32.0	60.0	12.25	85.00	252.0	32	38.00	21.50	61.75
B-114-119-86	94.00	138.0	78.25	174.38	28.75	218.0	33.0	60.0	12.25	70.00	224.0	32	38.00	21.50	61.75
B-114-133-74	81.00	138.0	78.25	174.38	28.75	218.0	45.3	60.0	12.25	57.00	211.0	32	38.00	21.50	61.75
B-114-143-64	70.00	138.0	78.25	174.38	28.75	218.0	46.0	60.0	12.25	46.00	200.0	32	38.00	21.50	61.75
B-80-119-64	71.00	116.0	53.8	148.0	26.2	175.8	32.0	42.75	10.00	55.00	188.0	16	47.50	21.50	50.00
B-80-76-64	71.00	116.0	53.8	148.0	26.2	175.8	32.0	42.75	10.00	55.00	188.0	16	47.50	21.50	50.00
B-80-76-54	60.00	98.7	36.5	148.0	26.2	158.5	32.0	42.75	10.00	44.18	177.0	16	47.50	21.50	50.00
B-80-109-48	60.00	98.7	38.0	148.0	26.2	155.5	43.0	42.75	10.00	44.18	176.9	16	47.50	21.50	50.00
B-80-109-42	48.00	98.7	39.0	148.0	26.2	148.5	41.6	42.75	10.00	31.50	148.8	16	47.50	21.50	50.00
B-57-76-54	60.00	98.7	40.0	148.0	26.2	162.0	30.8	42.75	10.00	44.18	177.0	16	47.50	21.50	50.00
B-57-109-48	60.00	98.7	41.5	148.0	26.2	159.0	41.0	42.75	10.00	44.18	176.9	16	47.50	21.50	50.00
B-57-109-42	48.00	98.7	42.5	148.0	26.2	152.0	39.6	42.75	10.00	31.50	148.8	16	47.50	21.50	50.00
B-50-89-54	60.00	96.5	40.0	148.5	22.1	162.3	30.8	42.75	8.00	44.00	177.0	16	37.25	14.81	35.50
B-50-89-48	60.00	96.5	41.5	148.5	22.1	159.0	41.0	42.75	8.00	43.62	176.9	16	37.25	14.81	35.50
B-50-89-42	48.00	96.5	42.5	133.5	22.1	152.0	39.6	42.75	8.00	32.00	148.8	16	37.25	14.81	35.50
B-40-76-48	56.00	96.5	36.5	148.5	22.1	156.5	42.9	42.75	8.00	41.25	172.2	16	36.50	14.81	35.50
B-40-89-42	48.00	96.5	42.5	133.5	22.1	152.0	39.6	42.75	8.00	32.00	149.5	16	37.25	14.81	35.50
B-40-76-42	48.00	96.5	40.0	133.5	22.1	151.0	40.2	42.75	8.00	32.00	149.5	16	36.50	14.81	35.50
B-40-89-36	48.00	96.5	48.9	133.5	22.1	146.8	48.6	42.75	8.00	32.00	149.5	16	37.25	14.81	35.50
B-25-67-36	38.25	83.0	35.5	110.0	17.8	128.8	27.3	36.00	8.00	34.25	117.8	16	44.50	13.13	34.88
B-25-56-36	38.25	83.0	33.3	110.0	17.8	126.8	25.2	36.00	8.00	34.25	118.0	16	44.50	13.13	34.88
B-25-67-30	38.25	83.0	41.3	110.0	17.8	125.1	44.4	36.00	8.00	34.25	117.2	16	44.50	13.13	34.88
B-25-53-30	38.25	83.0	39.8	110.0	17.8	123.2	42.3	36.00	8.00	34.25	117.1	16	44.50	13.13	34.88

NOTE: Do not use above dimensions for foundation. Request foundation plan.

CHURCHILL® BRAND BEAM BALANCED PUMPING UNITS

Churchill has been the industry's preferred brand of beam balanced units since 1954, and became part of the Lufkin family in 1991.

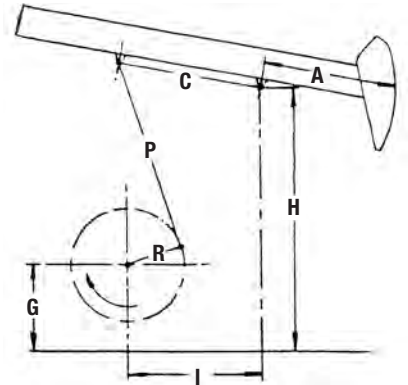

API Geometry Dimensions (inches)

Unit Size	A	C1	C2	I	P	H	G	R1, R2	S.U.*	T.F.@ 90°/Stroke Length
B-114-119-100	109.00	49.75	63.25	58.00	123.50	152.00	28.75	22, 16	127	48.148/100
B-114-119-86	94.00	50.00	63.50	58.00	109.50	138.00	28.75	22, 16	216	41.294/86
B-114-133-74	81.00	50.25	63.75	58.00	109.50	138.00	28.75	22, 16	405	35.403/74
B-114-143-64	70.00	50.00	63.50	58.00	109.50	138.00	28.75	22, 16	652	30.751/64
B-80-119-64	71.00	41.75	49.25	47.38	90.50	116.13	26.13	18, 14	381	30.577/64
B-80-76-64	71.00	41.75	49.25	47.38	90.50	116.13	26.13	18, 14	192	30.577/64
B-80-76-54	60.00	41.50	49.00	47.38	73.00	98.63	26.13	18, 14	268	25.972/54
B-80-109-48	60.00	46.00	53.50	47.38	73.00	98.63	26.13	18, 14	361	23.322/48
B-80-109-42	48.00	42.75	50.25	47.38	73.00	98.63	26.13	18, 14	378	20.149/42
B-57-76-54	60.00	41.50	49.00	47.38	73.00	98.63	26.13	18, 14	268	25.972/54
B-57-109-48	60.00	46.00	53.50	47.38	73.00	98.63	26.13	18, 14	361	23.322/48
B-57-109-42	48.00	42.75	50.25	47.38	73.00	98.63	26.13	18, 14	378	20.149/42
B-50-89-54	60.00	41.50	49.00	46.63	74.38	96.63	22.13	18, 14	252	25.899/54
B-50-89-48	60.00	46.25	53.75	46.63	74.38	96.63	22.13	18, 14	270	23.107/48
B-50-89-42	48.00	42.75	50.25	46.63	74.38	96.63	22.13	18, 14	376	20.089/42
B-40-76-48	56.00	43.75	51.25	46.63	74.38	96.63	22.13	18, 14	324	22.875/48
B-40-89-42	48.00	42.75	50.25	46.63	74.38	96.63	22.13	18, 14	376	20.089/42
B-40-76-42	48.00	42.75	50.25	46.63	74.38	96.63	22.13	18, 14	334	20.089/42
B-40-89-36	48.00	49.75	57.25	46.63	74.38	96.63	22.13	18, 14	427	17.082/36
B-25-67-36	38.25	26.66	32.66	30.00	66.88	83.00	17.81	12, 8	212	17.331/36
B-25-56-36	38.25	26.66	32.66	30.00	66.88	83.00	17.81	12, 8	172	17.331/36
B-25-67-30	38.25	31.65	37.65	30.00	66.88	83.00	17.81	12, 8	213	14.529/30
B-25-53-30	38.25	31.65	37.65	30.00	66.88	83.00	17.81	12, 8	207	14.529/30

*Structural Unbalance in pounds.

Counterbalance Data (shown in lbs., effective at polished rod with weights at maximum position, including structural unbalance.)

Unit	114-119-100	114-119-86	114-133-74	114-143-64	80-119-64	80-76-64	80-76-54	80-109-48	80-109-42	57-76-54	57-109-48	57-109-42
Stroke	100	86	74	64	64	64	54	48	42	54	48	42
Structural Unbalance	127	216	405	652	381	192	268	361	378	268	361	378
0 wts.	173	270	468	725	421	233	316	414	440	316	414	440
1 wts.	443	554	797	1,105	761	572	716	814	869	716	814	869
2 wts.	710	835	1123	1,483	1,096	907	1,112	1,210	1,293	1,112	1,210	1,293
3 wts.	975	1,113	1,446	1,856	1,428	1,239	1,504	1,602	1,712	1,504	1,602	1,712
4 wts.	1,237	1,388	1,765	2,225	1,756	1,567	1,892	1,990	2,122	1,892	1,990	2,125
5 wts.	1,497	1,660	2,081	2,591	2,080	1,892	2,275	2,373	2,533	2,275	2,373	2,533
6 wts.	1,755	1,930	2,394	2,953	2,401	2,213	2,653	2,751	2,935	2,653	2,751	2,935
7 wts.	2,010	2,197	2,704	3,312	2,718	2,530	3,028	3,126	3,332	3,028	3,126	3,332
8 wts.	2,262	2,461	3,010	3,666	3,032	2,843	3,398	3,495	3,723	3,398	3,495	3,723
9 wts.	2,513	2,722	3,313	4,017	3,341	3,153	3,763	3,861	4,109	3,763	3,861	4,109
10 wts.	2,761	2,981	3,613	4,364	3,647	3,459	4,124	4,222	4,489	4,124	4,222	4,489
11 wts.	3,006	3,236	3,910	4,707	3,949	3,761	4,481	4,579	4,864	4,481	4,579	4,864
12 wts.	3,249	3,489	4,204	5,047	4,248	4,059	–	4,931	5,234	4,833	4,931	5,234
13 wts.	3,490	3,739	4,494	5,383	4,543	4,354	–	5,279	5,598	5,181	5,279	5,598
14 wts.	3,728	3,986	4,781	5,715	4,834	4,645	–	5,623	5,956	–	5,623	5,956
15 wts.	3,964	4,231	5,064	6,043	5,121	4,933	–	5,962	6,309	–	5,962	6,309
16 wts.	4,198	4,473	5,345	6,368	5,405	–	–	6,297	6,657	–	6,297	6,657
17 wts.	4,429	4,712	5,622	6,688	5,685	–	–	6,628	6,999	–	6,628	6,999
18 wts.	4,657	4,948	5,896	7,006	5,962	–	–	6,954	–	–	6,954	7,335
19 wts.	4,884	5,181	6,167	7,319	6,234	–	–	7,276	–	–	7,276	7,666
20 wts.	5,108	5,411	6,434	7,628	6,503	–	–	7,593	–	–	7,593	7,992
21 wts.	5,329	5,639	6,699	7,934	6,768	–	–	–	–	–	–	–
22 wts.	5,548	5,864	6,960	8,236	7,030	–	–	–	–	–	8,215	–
23 wts.	5,765	6,086	7,218	8,535	7,288	–	–	–	–	–	8,519	–
24 wts.	5,979	6,306	7,472	8,829	7,542	–	–	–	–	–	–	–
25 wts.	6,191	6,522	7,723	9,120	7,793	–	–	–	–	–	–	–
26 wts.	6,400	6,736	7,472	9,407	8,039	–	–	–	–	–	–	–
27 wts.	6,607	6,947	8,216	9,690	8,282	–	–	–	–	–	–	–
28 wts.	6,812	7,155	8,458	9,970	8,522	–	–	–	–	–	–	–
29 wts.	7,014	7,361	8,696	10,246	8,758	–	–	–	–	–	–	–
30 wts.	7,214	7,563	8,931	10,518	8,990	–	–	–	–	–	–	–
31 wts.	7,411	7,763	9,163	–	9,218	–	–	–	–	–	–	–
32 wts.	7,606	7,960	9,392	–	–	–	–	–	–	–	–	–
33 wts.	7,798	8,154	9,617	–	–	–	–	–	–	–	–	–
34 wts.	7,989	8,346	9,839	–	–	–	–	–	–	–	–	–
35 wts.	8,176	8,534	–	–	–	–	–	–	–	–	–	–
36 wts.	9,362	8,720	–	–	–	–	–	–	–	–	–	–
37 wts.	8,544	8,903	–	–	–	–	–	–	–	–	–	–
38 wts.	8,725	–	–	–	–	–	–	–	–	–	–	–
39 wts.	8,903	–	–	–	–	–	–	–	–	–	–	–
40 wts.	9,079	–	–	–	–	–	–	–	–	–	–	–
41 wts.	9,252	–	–	–	–	–	–	–	–	–	–	–
42 wts.	9,423	–	–	–	–	–	–	–	–	–	–	–

CHURCHILL® BRAND BEAM BALANCED PUMPING UNITS



Counterbalance Data (shown in lbs., effective at polished rod with weights at maximum position, including structural unbalance.)

Unit	50-89-54	50-89-48	50-89-42	40-89-42	40-76-48	40-76-42	40-89-36	25-67-36	25-56-36	25-67-30	25-53-30
Stroke	54	48	42	42	48	42	36	36	36	30	30
Structural Unbalance	252	270	376	376	324	334	427	212	172	213	207
0 wts.	301	325	439	439	380	398	501	238	198	244	238
1 wts.	702	725	869	869	802	827	931	655	615	661	655
2 wts.	1,098	1,121	1,293	1,293	1,219	1,251	1,355	1,065	1,025	1,071	1,065
3 wts.	1,490	1,513	1,712	1,712	1,631	1,670	1,774	1,468	1,428	1,474	1,468
4 wts.	1,877	1,901	2,125	2,125	2,038	2,083	2,187	1,865	1,824	1,871	1,864
5 wts.	2,260	2,284	2,532	2,532	2,441	2,491	2,595	2,254	2,214	2,260	2,254
6 wts.	2,639	2,662	2,935	2,935	2,839	2,893	2,997	2,637	2,596	2,643	2,636
7 wts.	3,013	3,036	3,331	3,331	3,233	3,290	3,394	3,012	2,972	3,019	3,012
8 wts.	3,383	3,406	3,723	3,723	3,622	3,681	3,785	3,381	3,341	3,387	3,381
9 wts.	3,748	3,772	4,109	4,109	4,006	4,067	4,171	3,743	3,703	3,749	-
10 wts.	4,110	4,133	4,489	4,489	4,385	4,447	4,551	4,098	4,058	4,105	-
11 wts.	4,466	4,490	4,864	4,864	4,760	4,822	4,926	4,447	-	4,453	-
12 wts.	4,819	4,842	5,233	5,233	5,130	5,191	5,295	4,788	-	4,794	-
13 wts.	5,167	5,190	5,597	5,597	5,496	-	5,659	-	-	-	-
14 wts.	5,510	5,534	5,956	5,956	-	-	6,018	-	-	-	-
15 wts.	5,850	5,873	6,309	6,309	-	-	6,371	-	-	-	-
16 wts.	6,185	6,208	-	6,656	-	-	-	-	-	-	-
17 wts.	6,515	6,539	-	-	-	-	-	-	-	-	-
18 wts.	6,841	6,865	-	-	-	-	-	-	-	-	-
19 wts.	-	-	-	-	-	-	-	-	-	-	-
20 wts.	-	-	-	-	-	-	-	-	-	-	-
21 wts.	-	-	-	-	-	-	-	-	-	-	-

Structural Data

Unit Size	Polished Rod Capacity (lbs.)	Stroke Lengths (inches)	Equalizer Bearing (type)	Center Bearing (type)	Crank Pin Bearings (type)	Wireline Hanger (inches)
B-114-119-100	11,900	100, 72, 77, 56	Friction-ease	Friction-ease	Spherical Roller	.88 x 9 CTRS.
B-114-119-86	11,900	86, 62, 67, 48	Friction-ease	Friction-ease	Spherical Roller	.88 x 9 CTRS.
B-114-133-74	13,300	74, 53, 57, 41	Friction-ease	Friction-ease	Spherical Roller	.88 x 9 CTRS.
B-114-143-64	14,300	64, 46, 50, 36	Friction-ease	Friction-ease	Spherical Roller	.88 x 9 CTRS.
B-80-119-64	11,900	64, 54, 49, 41	Friction-ease	Friction-ease	Spherical Roller	.75 x 7 CTRS.
B-80-76-64	7,600	64, 54, 49, 41	Friction-ease	Friction-ease	Spherical Roller	.75 x 7 CTRS.
B-80-76-54	7,600	54, 45, 41, 35	Friction-ease	Friction-ease	Spherical Roller	.75 x 7 CTRS.
B-80-109-48	10,900	48, 41, 37, 32	Friction-ease	Friction-ease	Spherical Roller	.75 x 7 CTRS.
B-80-109-42	10,900	42, 35, 32, 27	Friction-ease	Friction-ease	Spherical Roller	.75 x 7 CTRS.
B-57-76-54	7,600	54, 45, 41, 35	Friction-ease	Friction-ease	Spherical Roller	.75 x 7 CTRS.
B-57-109-48	10,900	48, 41, 37, 32	Friction-ease	Friction-ease	Spherical Roller	.75 x 7 CTRS.
B-57-109-42	10,900	42, 35, 32, 27	Friction-ease	Friction-ease	Spherical Roller	.75 x 7 CTRS.
B-50-89-54*	8,900	54, 45, 41, 35	Friction-ease	Friction-ease	Spherical Roller	.75 x 7 CTRS.
B-50-89-48*	8,900	48, 41, 37, 32	Friction-ease	Friction-ease	Spherical Roller	.75 x 7 CTRS.
B-50-89-42*	8,900	42, 35, 32, 27	Friction-ease	Friction-ease	Spherical Roller	.75 x 7 CTRS.
B-40-76-48	7,600	48, 40, 36, 31	Friction-ease	Friction-ease	Spherical Roller	.75 x 7 CTRS.
B-40-89-42	8,900	42, 35, 32, 27	Friction-ease	Friction-ease	Spherical Roller	.75 x 7 CTRS.
B-40-76-42	7,600	42, 35, 32, 27	Friction-ease	Friction-ease	Spherical Roller	.75 x 7 CTRS.
B-40-89-36	8,900	36, 31, 27, 24	Friction-ease	Friction-ease	Spherical Roller	.75 x 7 CTRS.
B-25-67-36	6,700	36, 29, 23, 19	Friction-ease	Friction-ease	Spherical Roller	.63 x 6 CTRS.
B-25-56-36	5,600	36, 29, 23, 19	Friction-ease	Friction-ease	Spherical Roller	.63 x 6 CTRS.
B-25-67-30	6,700	30, 25, 19-1/2, 16	Friction-ease	Friction-ease	Spherical Roller	.63 x 6 CTRS.
B-25-53-30	5,300	30, 25, 19-1/2, 16	Friction-ease	Friction-ease	Spherical Roller	.63 x 6 CTRS.

* Non API size



CHURCHILL® BRAND BEAM BALANCED PUMPING UNITS

lufkin.com

Portable Base Data (inches)

Unit Size	Base	Length	Width	Unit Size	Base	Length	Width	Unit Size	Base	Length	Width
B-114-119-100	GPB	237	83	B-80-109-42	GPB	206	72	B-40-89-42	GPB	188	46.5
B-114-119-100	EPB	204.5	83	B-80-109-42	EPB	160	72	B-40-89-42	EPB	162	46.5
B-114-119-86	GPB	237	83	B-57-76-54	GPB	206	72	B-40-76-42	GPB	188	46.5
B-114-119-86	EPB	204.5	83	B-57-76-54	EPB	160	72	B-40-76-42	EPB	162	46.5
B-114-133-74	GPB	237	83	B-57-109-48	GPB	206	72	B-40-89-36	GPB	188	46.5
B-114-133-74	EPB	204.5	83	B-57-109-48	EPB	160	72	B-40-89-36	EPB	162	46.5
B-114-143-64	GPB	237	83	B-57-109-42	GPB	206	72	B-25-67-36	GPB	167	40.5
B-114-143-64	EPB	204.5	83	B-57-109-42	EPB	160	72	B-25-67-36	EPB	132	40.5
B-80-119-64	GPB	206	72	B-50-89-54	GPB	188	46.5	B-25-56-30	GPB	167	40.5
B-80-119-64	EPB	160	72	B-50-89-54	EPB	177	46.5	B-25-56-30	EPB	132	40.5
B-80-76-64	GPB	206	72	B-50-89-48	GPB	188	46.5	B-25-67-30	GPB	167	40.5
B-80-76-64	EPB	160	72	B-50-89-48	EPB	177	46.5	B-25-67-30	EPB	132	40.5
B-80-76-54	GPB	206	72	B-50-89-42	GPB	188	46.5	B-25-53-30	GPB	167	40.5
B-80-76-54	EPB	160	72	B-50-89-42	EPB	162	46.5	B-25-53-30	EPB	132	40.5
B-80-109-48	GPB	206	72	B-40-76-48	GPB	188	46.5	–	–	–	–
B-80-109-48	EPB	160	72	B-40-76-48	EPB	177	46.5	–	–	–	–

EPB = Electric Portable Base
GPB = Gas Portable Base

Warranty

Lufkin Industries, Inc. warrants each new Churchill pumping unit to be free from defects in materials and workmanship for a period of three years from date of shipment from Lufkin's plant.

The obligation under this warranty is limited to the replacement or repair at our factory, or at a point designated by the manufacturer, of defective parts only. This warranty does not obligate manufacturer to bear cost of labor or transportation charges in connection with replacement.

This warranty will be void if equipment is not installed properly, and/or balanced and operated within outlined specifications of the manufacturer.

Warranty is not transferable and shall become effective upon shipment from Lufkin's plant.

LUFKIN's warranty is limited to one year with respect to parts that are subject to wear under normal operating conditions (including, but not limited to contact type oil or grease seals, hoses, belts, elastomeric parts, wireline, brake lining, brake cables, etc.).

LUFKIN

SPECIAL APPLICATION PUMPING UNITS



Lufkin manufactures sucker rod pumping units for numerous special applications including:

LPII Low Profile Pumping Units. A compact unit designed for installation in fields irrigated by traveling sprinkler systems or in urban areas where the low profile feature may be desirable. Several sizes of the unit can be shipped from the factory completely assembled.

Portable/Trailer Mount Pumping Units. The Lufkin Roadrunner™ is a trailer-mounted, self-contained conventional pumping unit that lowers for legal highway transport. It can be erected and fully functional in a few minutes at the well site. These units are available for sale, rental or lease.

Special Application Pumping Units

The need to efficiently increase production of oil and gas has stimulated the development of a complex industry driven by technology. And today, with demand for energy supplies growing in countries around the world, companies like Lufkin Industries must continue to expand their capabilities in broader and more efficient ways than ever before. This requires extensive and costly research, enormous capital investments and the hard-devoted work of many skilled and experienced people.

Founded in 1902, Lufkin Industries has designed, engineered and manufactured and supplied the worldwide petroleum industry with more sucker rod pumping units than any other industry manufacturer. Lufkin pumping units are designed to help producers lower their production costs and optimize well efficiency. The company has earned a reputation throughout the industry for quality design, construction, dependability, innovation and service.

Over the years, Lufkin has introduced many different pumping unit designs. Designs like the Mark II with its unique geometry and phased counterbalance feature lowers peak torque and horsepower requirements. The Lufkin Air Balanced units use compressed air instead of heavy cast iron counterweights for accurate, fingertip control of counterbalance.

Customers frequently ask Lufkin engineers to design pumping units for special, and sometimes, unusual applications. Lufkin does not shy away from unusual requests. If an alternative means of providing the reciprocating motion to activate a downhole rod pump can be employed, Lufkin engineers can design it. If it will help operators to efficiently increase production of their wells, Lufkin will build it.

The four pages that follow detail the specifications of several Lufkin units that have been designed and manufactured to meet special requests:

- PowerLift folding beam units designed for use in overhead irrigated fields where a large gearbox and longer stroke are needed.
- LP11 low profile pumping units designed for installation in fields irrigated by traveling sprinkler systems or in urban areas where the low profile feature may be more aesthetic.
- Portable/Trailer Mount pumping units designed as a self-contained conventional unit that lowers for legal highway transport.
- Slant Hole pumping units designed to pump deviated wells.

Regardless of your pumping requirements, Lufkin Industries has the experience and capability to help you profitably produce your wells.



Lufkin has always been the industry innovator in the design and manufacture of special application pumping units.

LPII LOW PROFILE PUMPING UNITS

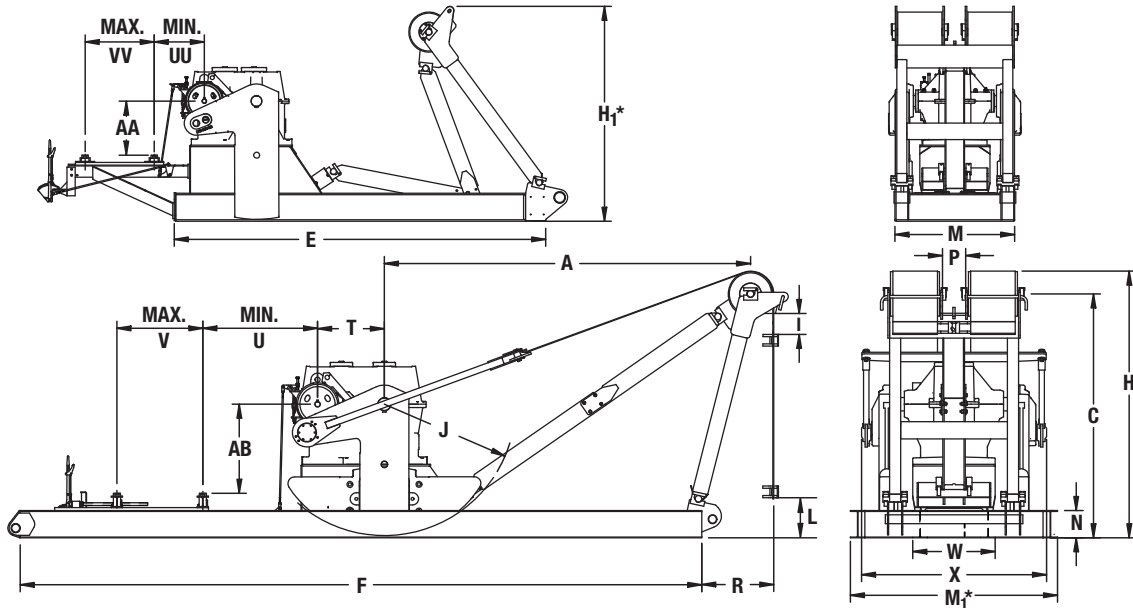

Dimensional Data (inches)

Unit Size	A	C	E	F	H	H1*	I	J	L	M	M1*	N	P	R	T	U	V	W	X	AA	AB	UU	VV
LPII-114D-173-54	118.00	86.00	133.00	-	96.00	-	3.72	46.50	16.80	59.75	-	14.00	10.38	25.00	24.00	-	-	28.00	67.00	14.00	-	25.00	34.50
LPII-160D-173-64	164.39	109.46	189.25	-	119.90	107.20	11.50	59.00	19.90	59.75	-	14.00	10.38	30.38	26.00	-	-	35.00	75.06	27.00	-	25.00	34.50
LPII-228D-173-74	164.39	109.46	189.25	306.00	119.90	107.20	3.52	59.00	18.00	59.75	93.00	14.00	10.38	30.38	30.00	51.50	50.81	40.00	83.06	27.00	39.90	28.25	31.20
LPII-320D-246-86	168.68	134.33	209.66	-	144.80	112.80	8.90	71.50	30.70	59.75	-	16.38	10.38	21.14	34.00	-	-	46.00	85.75	39.60	-	31.38	29.30

*Low Profile II units are available in either two-point foundation or wide-skid foundation designs. Dimension "M" is for two-point units and dimension "M₁" is for wide-skid units. Dimension "H₁" is the overall height of the unit when the rear leg is folded back.

NOTE: Do not use above dimensions for foundation. Request foundation plan.

Structural Data

Unit Size	Polished Rod Capacity (lbs.)	Adjustable Stroke Lengths (in.)	Crank Pin Bearing (type)	Roller Assembly	Cranks
LPII-114D-173-54	17,300	54, 44	3SX	20D	LPII 5447
LPII-160D-173-64	17,300	64, 54	3SX	20D	LPII 6459
LPII-228D-173-74	17,300	74, 64	3SX	20D	LPII 7459
LPII-320D-246-86	24,600	86, 74	3SX	20D	LPII 8672

Counterbalance Data (shown in lbs., effective at polished rod with weights at maximum position.)

Unit	LPII-114D-173-54		LPII-160D-173-64		LPII-228D-173-74		LPII-320D-246-86	
	54"	44"	64"	54"	74"	64"	86"	74"
Maximum Stroke	54"	44"	64"	54"	74"	64"	86"	74"
C'Bal., Cranks only	-	-	4,665	5,510	4,080	4,700	7,640	8,820
4 No. 3CRO Counterweights	-	-	-	-	-	-	13,935	16,070
4 No. 3BS Aux. weights	-	-	-	-	-	-	16,645	19,195
8 No. 3BS Aux. weights	-	-	-	-	-	-	19,355	22,315
4 No. 5ARO Counterweights	-	-	9,345	11,030	8,150	9,380	12,310	14,195
4 No. 5AS Aux. weights	-	-	11,225	13,245	9,785	11,260	14,180	16,350
8 No. 5AS Aux. weights	-	-	13,100	15,460	11,420	13,135	16,050	18,505
4 No. 5CRO Counterweights	-	-	8,140	9,610	7,105	8,180	11,100	12,805
4 No. 5CS Aux. weights	-	-	9,860	11,635	8,600	9,895	12,810	14,775
8 No. 5CS Aux. weights	-	-	11,580	13,660	10,100	11,615	14,520	16,745
4 No. 6RO Counterweights	-	-	7,425	8,760	6,480	7,460	10,345	11,935
4 No. 6 Aux. weights	-	-	8,465	9,990	7,385	8,500	11,365	13,110
8 No. 6 Aux. weights	-	-	9,505	11,220	8,290	9,540	12,385	14,285
4 No. 7RO Counterweights	-	-	6,455	7,620	5,635	6,490	9,415	10,865
4 No. 7 Aux. weights	-	-	7,250	8,560	6,330	7,285	10,200	11,770
8 No. 7 Aux. weights	-	-	8,050	9,500	7,020	8,080	10,990	12,680

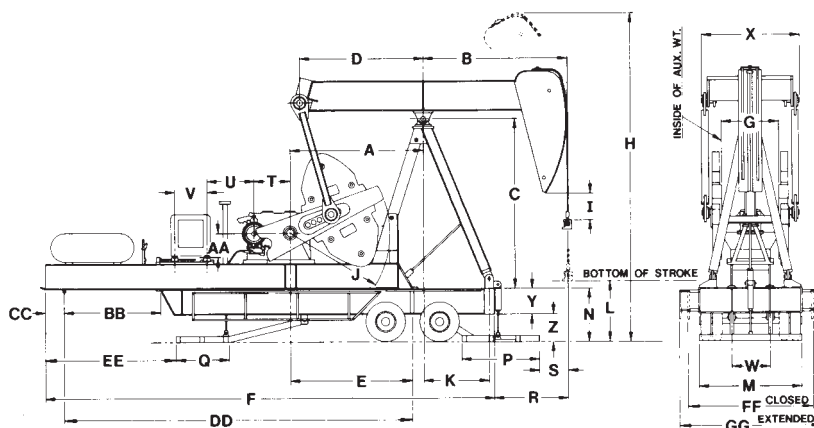

Dimensional Data (inches)

Unit Size	A	B	C	D	E	F	G	H	I	J	K	L	M	N	P	Q
CM-456D-305-120	124.00	159.38	159.75	115.00	113.00	417.50	52.50	326.44	17.94	92.00	61.00	66.00	96.00	51.88	59.00	48.00
CM-320D-305-100	124.00	133.50	157.75	115.00	113.00	417.50	44.75	308.69	32.88	92.00	61.00	71.31	96.00	51.88	47.00	48.00
CM-228D-246-86	118.00	113.50	151.18	114.06	121.00	354.00	38.63	283.75	20.75	78.00	37.00	67.06	96.00	46.63	48.00	48.00
CM-160D-173-74	118.00	115.13	151.06	114.06	107.00	372.00	33.13	277.38	43.13	78.00	37.00	69.25	96.00	47.00	48.00	48.00

Unit Size	R	S	T	U	V	W	X	Y	Z	AA	BB	CC	DD	EE	FF	GG
CM-456D-305-120	93.81	57.38	33.38	83.13	26.00	36.00	97.38	23.75	28.13	26.00	89.75	18.00	323.00	127.50	97.00	131.00
CM-320D-305-100	68.00	43.44	34.00	87.25	26.00	36.00	86.38	23.75	28.13	26.00	89.75	18.00	323.00	127.50	97.00	131.00
CM-228D-246-86	73.00	48.50	30.00	72.75	26.00	26.13	78.50	23.63	23.00	20.50	90.00	24.00	292.50	117.25	95.00	111.50
CM-160D-173-74	73.63	50.13	26.00	70.00	26.00	26.13	70.50	23.75	23.25	14.38	90.00	24.00	295.50	128.50	95.00	109.00

Structural Data

Unit Size	Polished Rod Capacity (lbs.)	Stroke Lengths (inches)	Walking Beam	Wireline Hanger (inches)	Cranks (type)	Crank Pin Bearing	Equalizer Bearing	Center Bearing	Engine Type	Engine HP @ 1800 RPM
CM-456D-305-120	30,500	120, 101, 84, 66	W27 x 161	1.25 x 12 CTRS.	8492RX	2SE	2SE	1MTG	CAT3304G	83
CM-320D-305-100	30,500	100, 84, 70, 55	W27 x 146	1.25 x 12 CTRS.	8492RX	2SE	2SE	2MTG	WAUESHA 330G	63
CM-228D-246-86	24,600	83, 73, 60, 48	W27 x 117	1.13 x 12 CTRS.	8478RX	3SF	3SF	2MTG	WAUESHA 220G	41
CM-160D-173-74	17,300	74, 61, 48, 36	W24 x 84	1.00 x 9 CTRS.	7278RX	3SF	3SF	2MTG	WAUESHA 220G	41

Counterbalance Data

(Maximum counterbalance shown in lbs., effective at polished rod with weights at maximum position. Minimum counterbalance shown is with weights moved all the way in on the crank. These figures include structural unbalance.)

Unit	CM-456D-305-120		CM-320D-305-100		CM-228D-246-86		CM-160D-173-74	
Maximum Stroke	120"		100"		86"		74"	
Structural Unbalance	125 LBS.		400 LBS.		630 LBS.		700 LBS.	
Cranks	8492RX		8492RX		8478RX		7278RX	
C'Bal., Cranks only	6,495		8,015		5,960		6,770	
	MAX.	MIN.	MAX.	MIN.	MAX.	MIN.	MAX.	MIN.
4 No. ORO Counterweights	21,145	8,105	-	-	-	-	-	-
4 No. OARO Counterweights	19,075	6,875	-	-	-	-	-	-
4 No. OAS Aux. weights	22,970	6,990	-	-	-	-	-	-
4 No. 1R0 Counterweights	16,265	6,605	19,695	8,150	-	-	-	-
4 No. 1S Aux. weights	19,270	6,640	23,285	8,190	-	-	-	-
8 No. 1S Aux. weights	22,275	6,675	-	-	-	-	-	-
4 No. 2R0 Counterweights	14,770	6,500	17,910	8,025	-	-	-	-
4 No. 2S Aux. weights	17,735	6,505	21,455	8,030	-	-	-	-
8 No. 2S Aux. weights	20,700	6,510	25,000	8,035	-	-	-	-
4 No. 3CRO Counterweights	13,195	6,205	16,025	7,665	13,540	5,430	-	-
4 No. 3BS Aux. weights	16,085	6,080	19,480	7,515	16,810	5,200	-	-
8 No. 3BS Aux. weights	18,975	5,955	22,935*	7,365	-	-	-	-
4 No. 5ARO Counterweights	11,430	5,820	13,915	7,210	11,630	4,885	13,225	5,550
4 No. 5A Aux. weights	13,410	5,550	16,280	6,885	13,905	4,455	15,815	5,060
8 No. 5A Aux. weights	15,390	5,280	18,645*	6,560	16,180	4,025	17,110	4,815
4 No. 5CRO Counterweights	-	-	-	-	10,140	5,155	11,530	5,850
4 No. 5CS Aux. weights	-	-	-	-	12,205	4,755	13,880	5,395
8 No. 5CS Aux. weights	-	-	-	-	14,270	4,355	15,055*	5,170
4 No. 6RO Counterweights	-	-	-	-	9,220	5,285	10,480	6,000
4 No. 6 Aux. weights	-	-	-	-	10,450	5,030	11,880	5,710
8 No. 6 Aux. weights	-	-	-	-	11,680	4,775	13,280	5,420
4 No. 7RO Counterweights	-	-	-	-	8,045	5,495	9,140	6,240
4 No. 7 Aux. weights	-	-	-	-	8,970	5,290	10,195	6,005
8 No. 7 Aux. weights	-	-	-	-	9,895	5,085	11,250	5,770

GEAR REDUCER AND LUBRICATION DATA

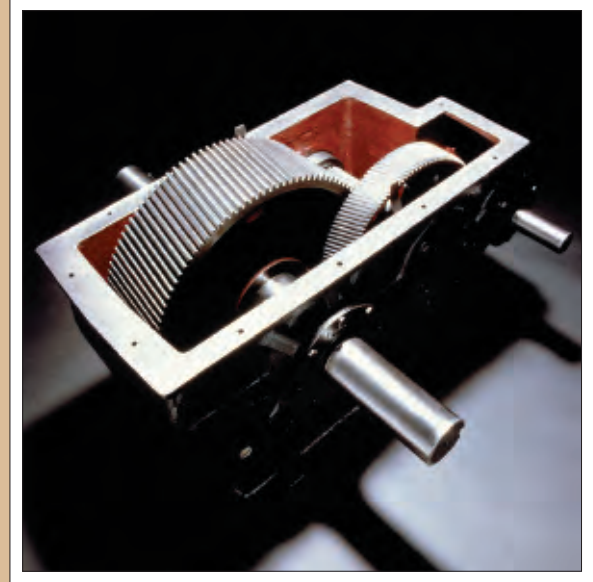
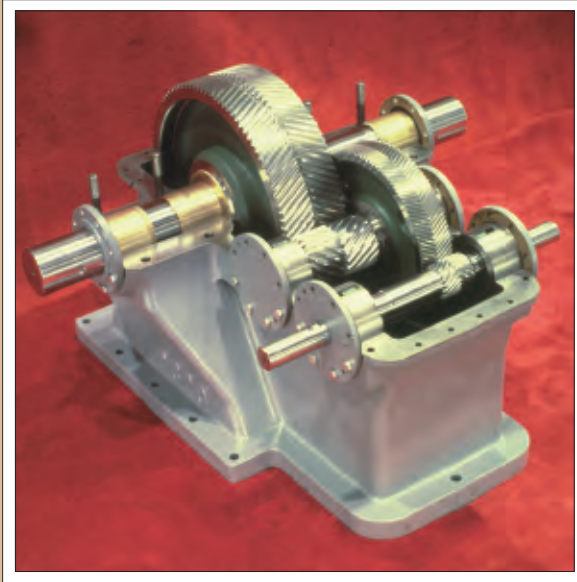

Lufkin designed and manufactured herringbone gears (double helical) have proven to be the standard of excellence for pumping unit gear reducers. Herringbone gears are less sensitive to misalignment and resist torque reversals better than other types of gears. Heavy-duty sleeve bushings on the crankshaft and straight roller bearings on the high speed and intermediate shafts need no adjustment at assembly or when field service is required. The nodular iron gears with high strength alloy pinion used by most manufacturers of pumping units were pioneered by Lufkin in 1951. The rugged two-piece housing is manufactured specifically for oilfield pumping applications.

Churchill's precision-cut helical gears are encased in a strong, heavy-walled, cast-iron gear reducer housing. For smaller, beam balanced pumping units, these gear reducers are the most economical and reliable available. Incorporated into the high speed end of the gear reducer is Churchill's unique StepDown™ design, which minimizes shaft deflection and improves proper gear meshing. Positive lubrication of the heat treated, nodular gears and steel alloy pinions is ensured by a wiper-type system. A built-in sight gauge allows immediate visual inspection of the oil level in the gear reducer housing. All tapered roller bearing cups are mounted in bearing carriers, a unique configuration which minimizes field replacement time and also prevents damage to the housing should a bearing fail.

Lufkin Gear Reducer Data

Gear Reducer Size	Peak Torque Rating (in. lbs.)	Gear Ratio	Crankshaft Diameter Conventional / Mark II (inches)	Sheave Bore Dia. (inches)	Sheave Options		Gear Reducer Oil Capacity (gallons)
					Belt Section / Pitch Dia.** (inches)	Belt Section / Pitch Dia.** (inches)	
2560D	2,560,000	34.53:1	11.75	6.50	12D / 55, 68	-	235
1824D	1,824,000	28.33:1	9 / 10.5	4.94	10D / 55, 68	-	165
1280D	1,280,000	28.05:1	8.5 / 10.5	4.94	8D / 35, 68	10C / 36 , 68	120
912D	912,000	28.72:1	7 / 9*	4.19	6D / 33 , 40 , 48 , 55.2	8C / 50 , 55.2	107
640D	640,000	28.60:1	7 / 9	3.44	5D / 22 , 27 , 33 , 48 , 55.4	6C / 24 , 36 , 44 , 50 , 55.6	70
456D	456,000	29.04:1	7 / 9	3.44	4D / 22 , 27 , 33 , 48	6C / 24 , 36 , 44 , 50	55
320D	320,000	30.12:1	6.44 / 8.5	2.94	-	5C / 24 , 30 , 36 , 44 , 47	50
228D	228,000	28.45:1	6 / 7	2.44	-	4C / 24 , 30 , 36 , 41	34
160D	160,000	28.67:1	5.44 / 7	2.19	-	3C / 20 , 24 , 30 , 36 , 38	22
114D	114,000	29.40:1	4.44 / 6.44	1.94	-	2C / 20 , 24 , 30 , 33.6	17
80D	80,000	29.40:1	4.44	1.94	-	2C / 20 , 24 , 30 , 33.6	17
57D	57,000	29.32:1	4	1.94	3B / 20 , 25 , 27.6	2C / 20 , 24 , 27	13

* 10.5 for 912DS Mark II

** **Bold Face** type indicates standard size sheave. All other sizes are available for a nominal fee.

Lufkin Double Reduction Gear Reducers

All Lufkin gear reducers have been designed to exceed API and AGMA specifications. Lufkin is authorized to display the API monogram and is licensed under specification 11E. Lufkin precision-cut, herringbone gears are encased in a strong, heavy-walled, cast-iron gear reducer housing. Operating in an oil bath ensures positive lubrication of the heat-treated, nodular gears and steel alloy pinions. An oil wiper system continuously supplies oil to the bearings. An oil gauge dip stick allows easy inspection of the oil level in the gear reducer housing. Special features of these rugged oilfield reducers include:

- Horizontally split gear housing designed for easy field maintenance
- Precision-cut Lufkin herringbone gears
- All shafts made from alloy steel, heat treated and precision turned to tight tolerances
- Four oversized bronze bushings on crankshafts that seldom require replacement
- Positive lubrication system (no oil pumps required)
- Intermediate and high speed roller bearings.



Lubrication Instructions

Gear Reducer. For temperatures down to 0°F, use an AGMA No. 5EP (ISO VG 220) premium mild extreme pressure lubricant (preferably a sulphur-phosphorous type) with rust and oxidation inhibitors and an anti-foam agent. Pour point of the oil should be 5°F or lower. For temperatures down to -30°F, use an AGMA No. 4 EP (ISO VG 150) premium mild extreme pressure lubricant (preferably sulphur-phosphorous type) with rust and oxidation inhibitors and an anti-foam agent. Pour point of the oil should be -15°F or less. Do not use multi-viscosity oils.

If desired, units can be shipped with the gear reducer filled with oil that complies with the above specifications.

To obtain long life from a pumping unit reducer, it is necessary that the oil be of suitable viscosity and free from foreign material, sludge and water. Check for possible dirt, sludge, water emulsion or other forms of contamination every six months, or when the reducer has been exposed to flooding. If the lubricant has an abnormal appearance or smell, consider replacement.

Structural Bearings. All structural bearings are lubricated at the factory. However, structural bearings do require periodic relubrication.

In **warm climates** (lowest annual temperature above 0°F), roller bearings (except tapered roller crank pin bearings) should be lubricated every six months. Use a premium NLGI No. 1 lithium soap base grease with an extreme pressure additive and a base oil viscosity equivalent to AGMA No. 7 (414-506 cSt. at 40°C). Do not use soda soap grease.

Bronze bearings and tapered roller crank pin bearings should be lubricated as required to maintain oil level. Use an EP140 extreme pressure oil with an extreme pressure additive and a pour point of +15°F or lower. If available, the use of a heavier oil (viscosity up to 6600 SUS at 100°F) is recommended.

In **cold climates** (lowest annual temperature down to -30°F), roller bearings (except tapered roller crank pin bearings) should be lubricated every six months. Use a premium NLGI No. 0 lithium soap base grease with an extreme pressure additive and a base oil viscosity equivalent to AGMA No. 5 (198-242 cSt. at 40°C). Do not use soda soap grease.

Bronze bearings and tapered roller crank pin bearings should be lubricated as required to maintain oil level by removing the fill plug and adding oil until the reservoir is full. Use EP80 or EP90 extreme pressure oil with an extreme pressure additive and a pour point of -10°F or lower.

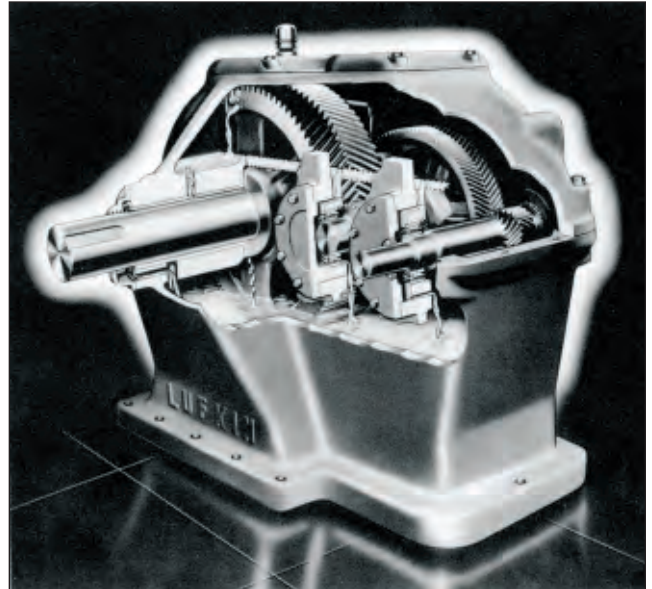

As long as the oil is maintained at the proper level, the slow speed and high speed gears dip in oil and provide continuous lubrication to the gear mesh. Large oil wipers direct a flood of oil into oversized oil troughs which in turn provide each individual bearing with more than adequate lubrication above five SPM.

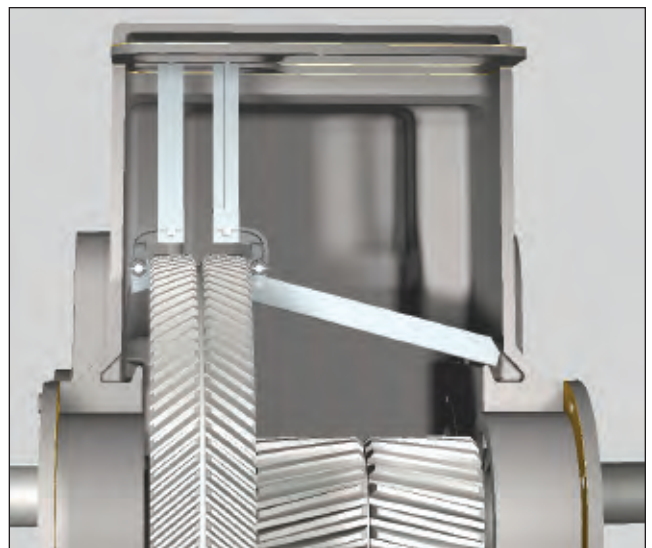

Consistent lubrication is essential even at low speed operation (below 5 SPM). This can be accomplished with the addition of optional high speed gear wipers for reducer sizes 912 and below. High speed gear wipers are standard equipment on reducer sizes 1280 and above.

Churchill Gear Reducer Data

Gear Reducer Size	Peak Torque Rating (in. lbs.)	Gear Ratio	Sheave Pitch Dia. (inches)	Sheave Belt Section	Gear Reducer Oil Capacity (gallons)	Gear Design	Crankshaft Bearings	Intermediate & High Speed Bearings
B-114	114,000	30:48;1	20, 24, 30	3-C	9	Double Helical	Tapered Roller	Cylindrical Roller
B-80	80,000	30.06:1	24	4-B, 3-C	13	Helical	Tapered Roller	Tapered Roller
B-57	57,000	31.57:1	24	4-B, 3-C	13	Helical	Tapered Roller	Tapered Roller
B-50	50,000	31.11:1	18.4	3-B	4	Helical	Tapered Roller	Tapered Roller
B-40	40,000	31.11:1	18.4	3-B	4	Helical	Tapered Roller	Tapered Roller
B-25	25,000	31.14:1	18.4	2-B	2	Helical	Tapered Roller	Tapered Roller

Churchill Helical Gear Reducers

Lufkin's Churchill brand gear reducers are also designed to exceed API and AGMA specifications. The precision-cut helical gears are encased in a heavy-walled cast-iron housing built to the same rugged standards as the larger Lufkin units. All tapered roller bearing cups are mounted in bearing carriers. This unique configuration minimizes field replacement time and prevents damage to the housing should a bearing fail. Special features include:

- Unique StepDown™ housing design, which minimizes shaft deflection and improves proper gear meshing.
- Positive lubrication by integral wiper system
- Built-in oil level sight gauge
- Precision-cut Lufkin helical gears
- All shafts made from high grade steel, heat treated and precision turned to tight tolerances

Lubrication Instructions

The proper care and lubrication of your Churchill brand pumping unit will assure many trouble-free years of operation.

Gear Reducer. For temperatures down to 0°F, use an AGMA No. 5EP (ISO VG 220) premium mild extreme pressure lubricant (preferably a sulphur-phosphorous type) with rust and oxidation inhibitors and an anti-foam agent. Pour point of the oil should be 5°F or lower. For temperatures down to -30°F use an AGMA No. 4 EP (ISO VG 150) premium mild extreme pressure lubricant (preferably a sulphur-phosphorous type) with rust and oxidation inhibitors and an anti-foam agent. Pour point of the oil should be -15°F or less. Do not use multi-viscosity oils.

If desired, units can be shipped with the gear reducer filled with oil that complies with the above specifications.

To obtain long life from a pumping unit reducer, it is necessary that the oil be of suitable viscosity and free from foreign material, sludge and water. Check for possible dirt, sludge, water emulsion or other forms of contamination every six months, or when the reducer has been exposed to flooding. If the lubricant has an abnormal appearance or smell, consider replacement.

Structural Bearings. All structural bearings are lubricated at the factory prior to shipment. However, structural bearings do require periodic relubrication.

The center, equalizer and crank pin bearings, in warm climates (lowest annual temperature above 0°F), should be lubricated with a premium NLGI No. 1 lithium soap base grease with an extreme pressure additive and a base oil viscosity equivalent to AGMA No. 7 (414-506 cSt. at 40°C). In cold climates (lowest annual temperature down to -30°F), use a premium NLGI No. 0 lithium soap base grease with an extreme pressure additive and a base oil viscosity equivalent to AGMA No. 5 (198-242 cSt. at 40°C). Do not use soda soap grease.

Each bearing assembly has a ground level grease fitting for easy lubrication with a grease gun. The bearing assemblies should be lubricated at six month intervals. In some environments, more frequent lubrication may be required.

LUFKIN

OPTIONAL EQUIPMENT AND SPECIAL FEATURES



Pumping units contain a number of heavy rotating and moving parts which constitute a safety hazard if not properly installed and guarded. As a service to the users of our pumping units, we offer several types of ladders, safety guarding and various optional equipment which provide ease of operation and safety for people, animals or assets.

Special Features

All Lufkin manufactured pumping units are widely known for extra-heavy structural frames. Wide flange beams provide a rugged structure that is capable of withstanding extreme well loads. Heavy steel risers and easy access bolting are standard features on all units. Ladders are standard on all larger structures. A wide variety of bases, prime mover base extensions and elevated motor brackets adapt easily to all well site conditions, engines and electric motors.

The following pages highlight some of the special features of Lufkin pumping units and a sampling of optional equipment that can be provided per customer requests.

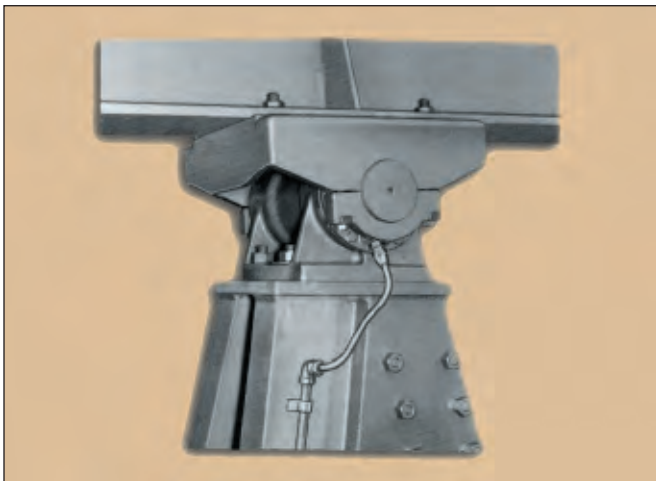

Center Bearing Assembly. Furnished with precision tapered roller bearings.



Flex-Shoe Brake. Provides much greater holding capacity than the Clam Shell type formerly used. Smoother acting with no "grabbing." Positive stop pawl can be engaged with notches in brake drum to provide additional safety. The pumping unit brake is not intended as a safety stop but is intended for operational stops only.

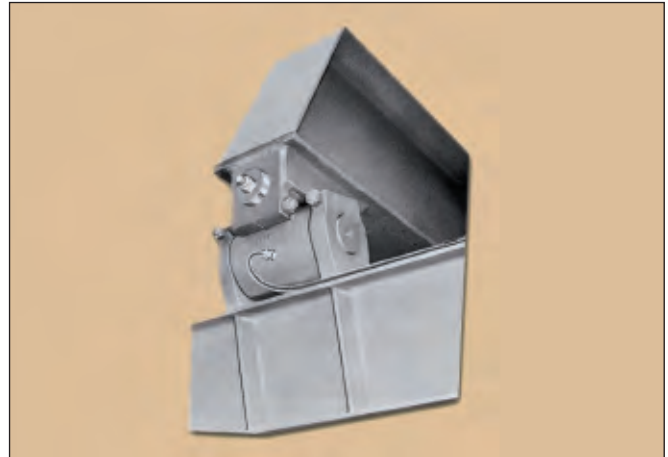

Crank Balanced Unit Equalizer Bearing Assembly. Furnished with heavy-duty needle roller bearings on all sizes. Cross-pin type connection to walking beam is utilized to improve alignment.

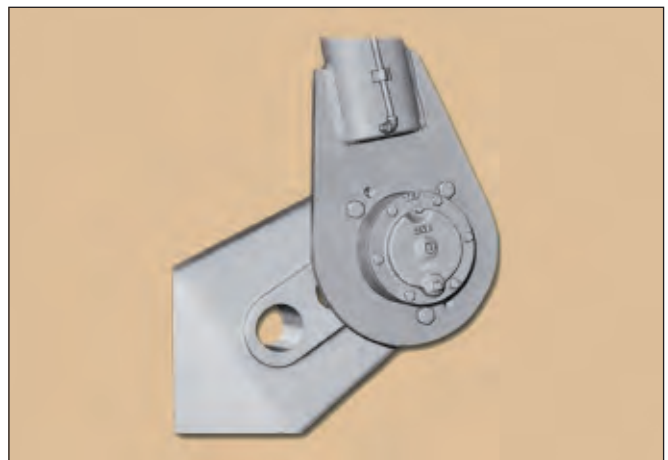

Crank Pin Assembly. Furnished with spherical roller bearings.



Horsehead/Wireline Assembly. Easily aligned with polished rod without disconnecting well load. One-piece arc plate is used for greater strength. The 120-inch stroke length and less units are furnished with roll-back horseheads for ease of well servicing.

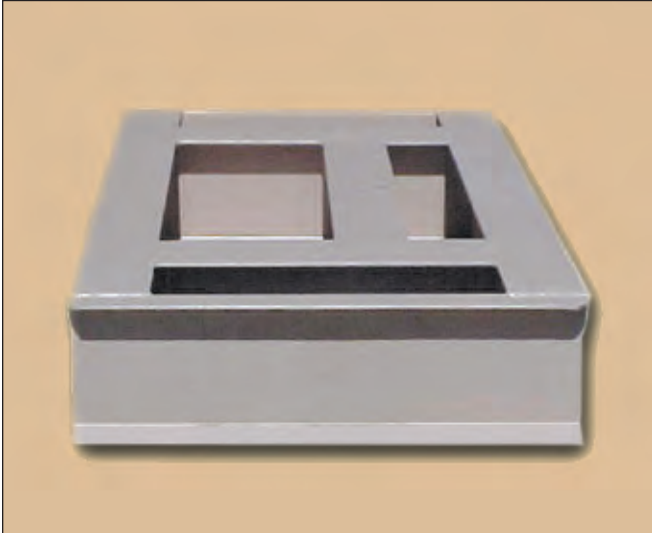

Fabricated Foundation Pads are available for use with all Mark II units and those conventional units designed for “two point” mounting. The light weight portable fabricated pads can be shipped with the pumping unit as a convenience and cost saving feature. Once the pads are in place they are filled with crushed rock or sand to add stabilizing weight.

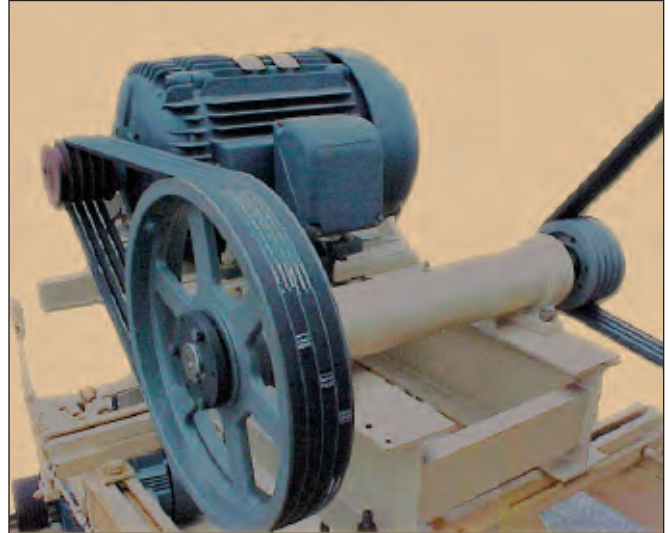

Jackshaft™ Speed Reducer. In many older oil fields where hydrocarbon recoveries are minimal, slowing down a pumping unit can lower a producer's costs and increase his profits. With an additional speed-reduction ratio capable of slowing the unit running speed to one or two strokes per minute, the Jackshaft Speed Reducer helps maximize efficiencies. The Jackshaft simply allows producers to keep their units running while lowering operating costs by avoiding frequent starting and stopping. It reduces motor horsepower requirements. And it fights corrosion which results from downtime.

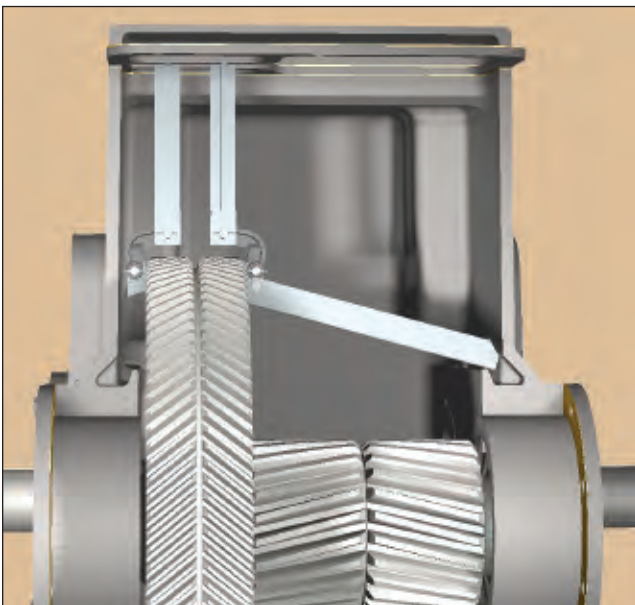

Consistent lubrication is essential even at low speed operation (below 5 SPM). This can be accomplished with the addition of optional high speed gear wipers for reducer sizes 912 and below. High speed gear wipers are standard equipment on reducer sizes 1280 and above.



Foundation Anchor Nuts are suspended in concrete forms before foundation is poured. Provides flush foundation. Wide foot at base of nut insures more than adequate holding power. Available in the following sizes:

Bolt Diameter (inches)	Length (inches)
0.75	6
1.00	10
1.25	12
1.50	12

Conventional Pumping Unit and Prime Mover Bases

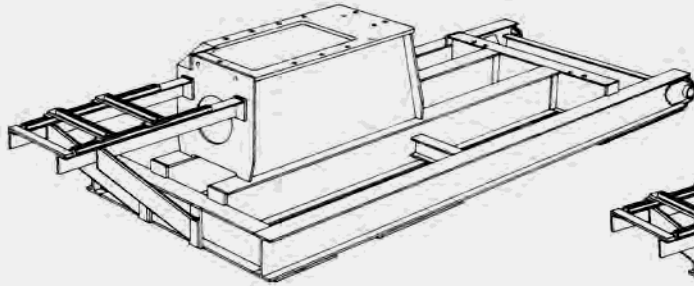

Wide Skid-UNISET base with Hi-Prime bracket for Electric Motor

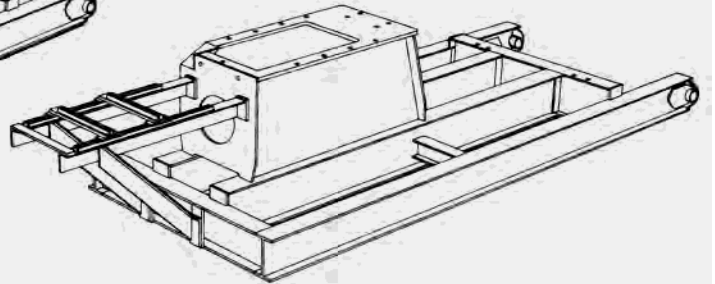

Wide Skid base with Hi-Prime bracket for Electric Motor

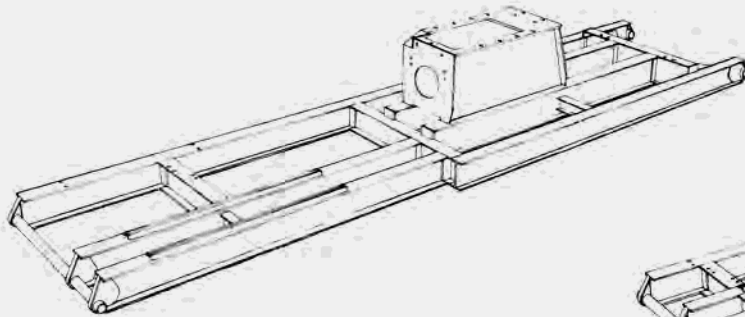

Wide Skid base for Slow Speed Engine

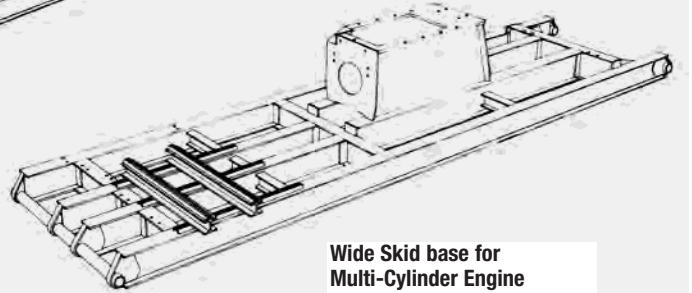

Wide Skid base for Multi-Cylinder Engine

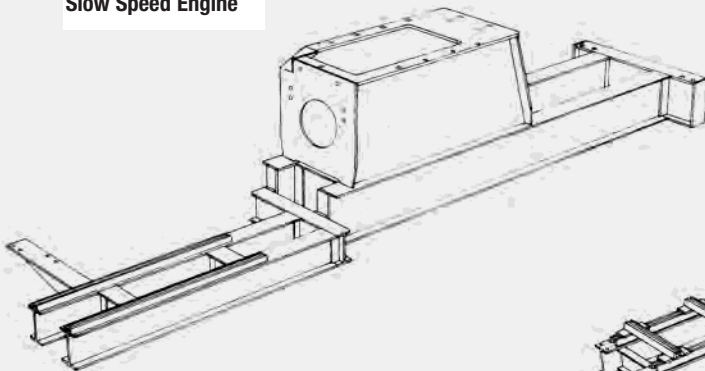

Jointed base for Slow Speed Engine

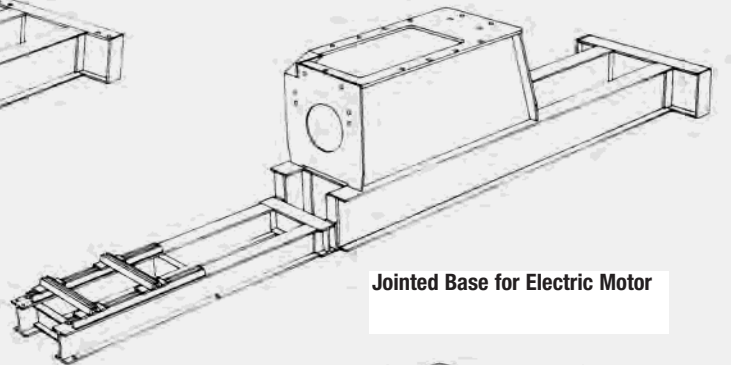

Jointed Base for Electric Motor

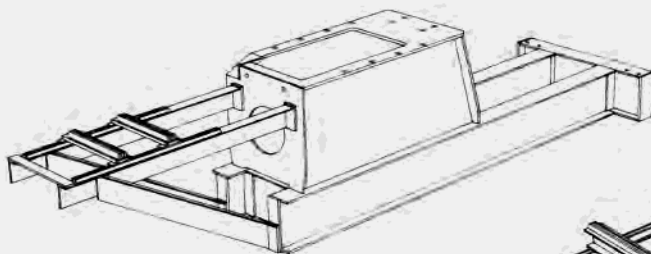

Stub Base with Hi-Prime Bracket for Electric Motor

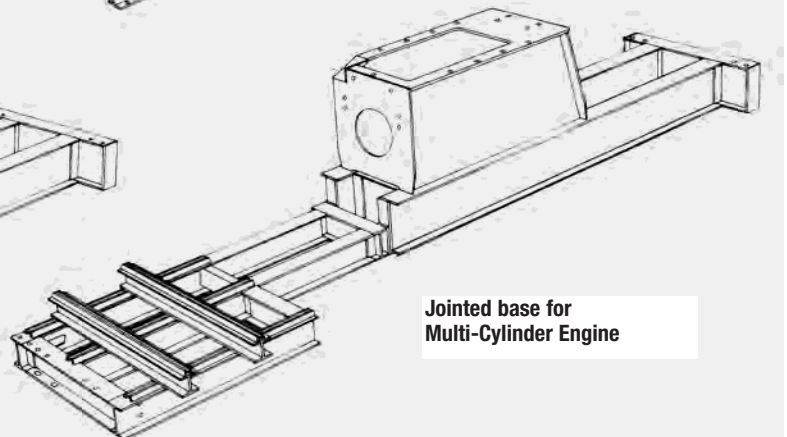

Jointed base for Multi-Cylinder Engine

Mark II Pumping Unit and Prime Mover Bases

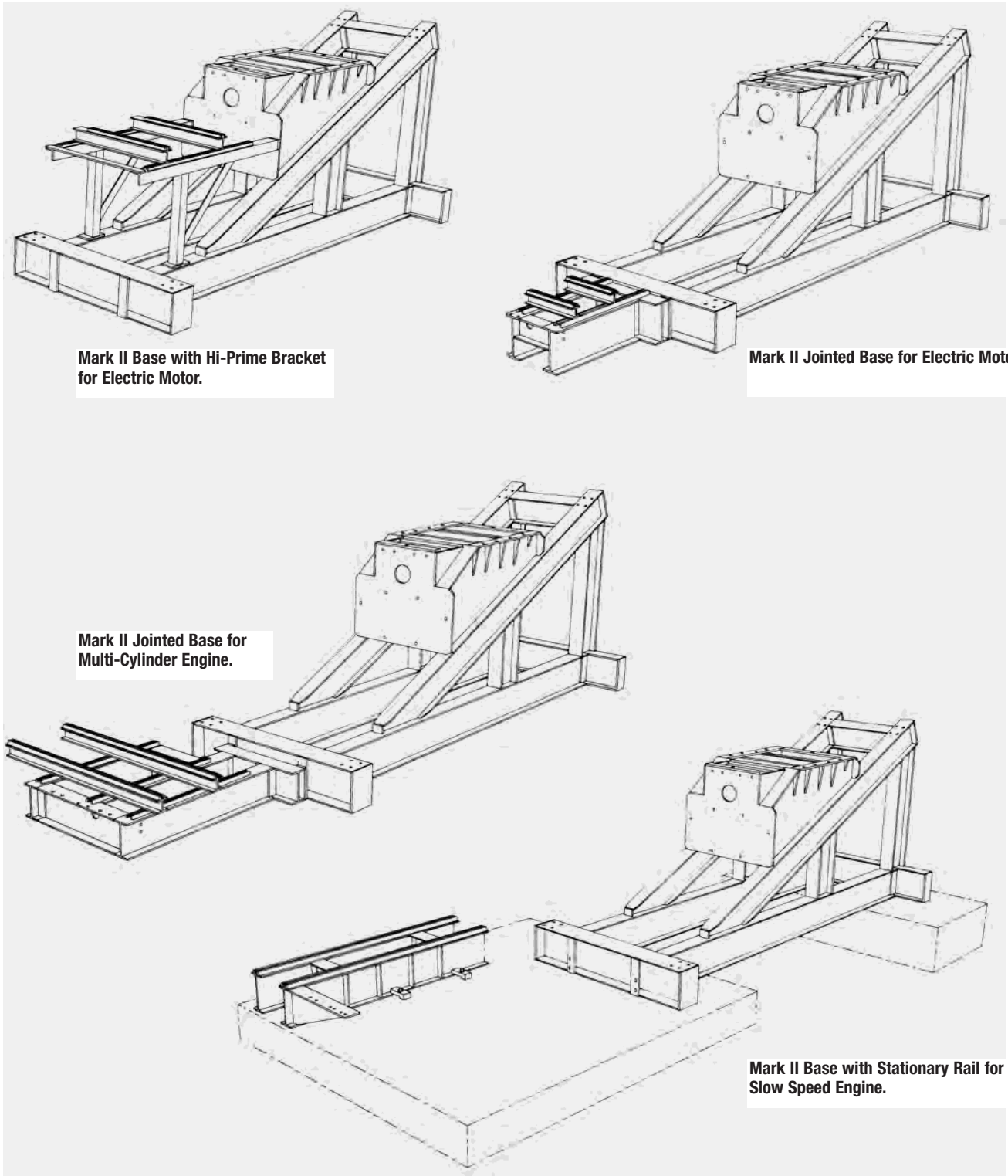

Mark II Base with Hi-Prime Bracket for Electric Motor.

Mark II Jointed Base for Electric Motor.

Mark II Jointed Base for Multi-Cylinder Engine.

Mark II Base with Stationary Rail for Slow Speed Engine.

Guarding of Pumping Units

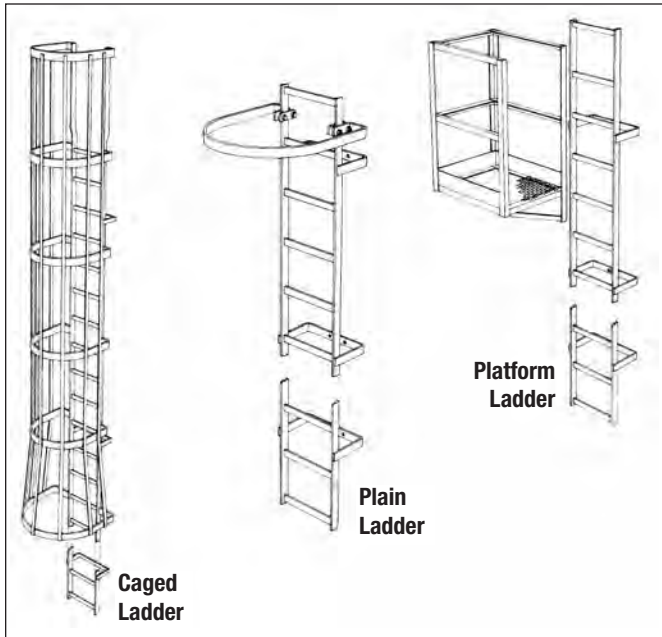

Lufkin ladders are designed to facilitate safe access to key parts of the pumping unit structure. Our standard ladders conform to Lufkin's interpretation of API RP11ER. Special application ladders can be manufactured to your specifications.

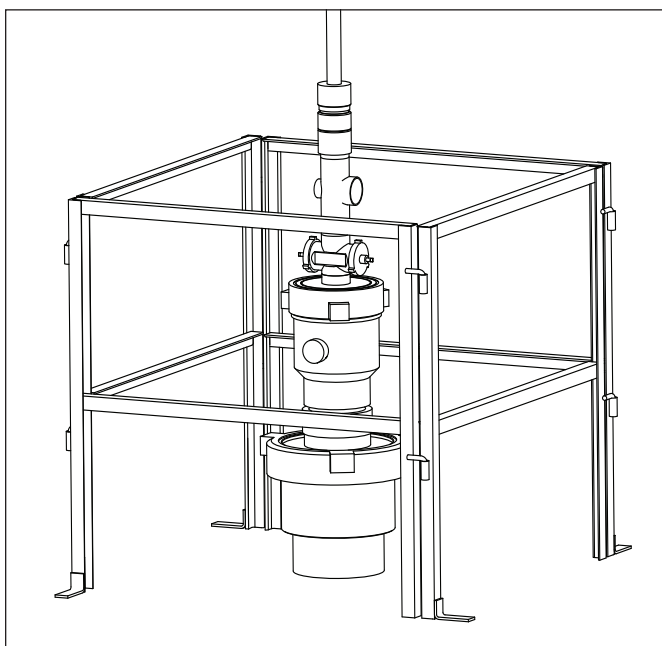

Horsehead Guards are available from Lufkin. This guard is designed to keep people who are familiar with the operation of pumping units from accidentally wandering into the area below the horsehead and carrier bar. This type guard is required where the horsehead or carrier bar descends to 7 ft or less from grade or work platform (refer to API11ER).

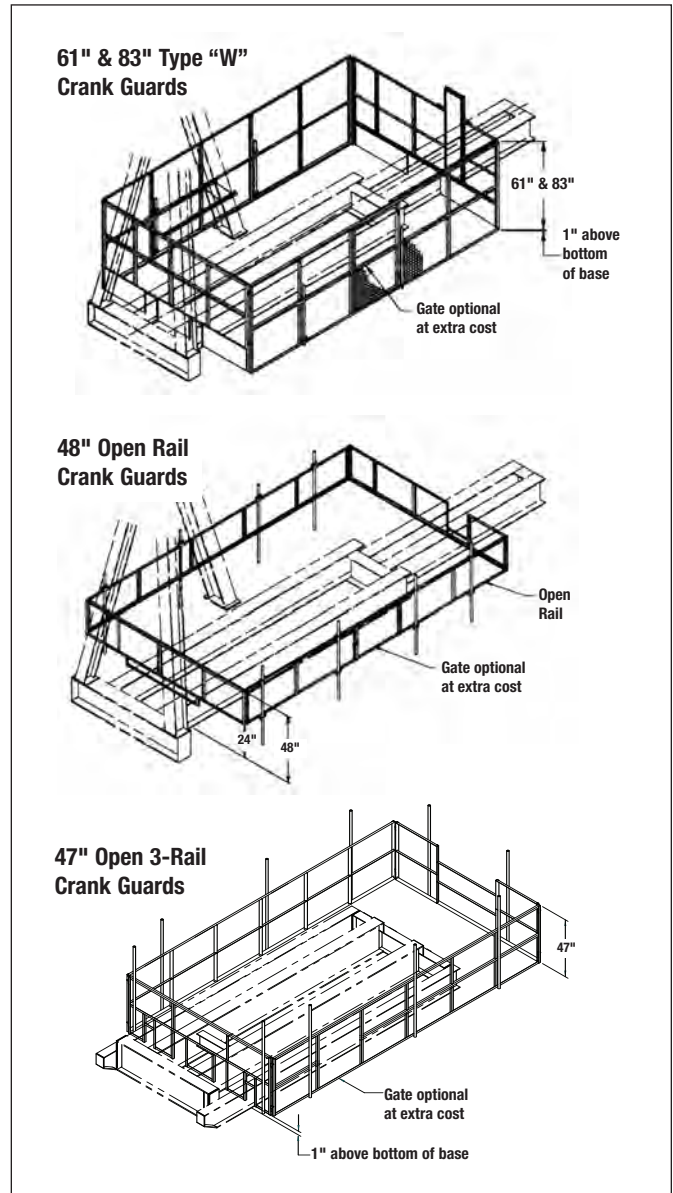

Crank Guards are available for all Lufkin units. In most operating environments, the 48-in. open-rail guards and the 47-in. open 3-rail guards are considered minimum guarding for people who are familiar with pumping units and are accustomed to servicing them. This type of guard is intended to keep workers from accidentally wandering, or falling, into the crank arm sweeps. The 61-in. and 83-in. wire-mesh guards should be specified where more stringent safety considerations are preferred. Custom guards are available to meet customer's individual requirements.

Belt Guards are furnished with each unit. They are designed to cover exposed sheaves and belts and to provide a barrier between these items and people who are familiar with the operation of pumping units. Replacement belt guards are available from Lufkin.

Prime Mover Guards are designed to keep people who are familiar with the operation of pumping units and engines from accidentally walking or falling into the flywheel. Guards are available from Lufkin.

LUFKIN

WORLDWIDE PARTS AND SERVICE



Lufkin's Oilfield Service Group refurbishes and sells used pumping units, and provides installation, field services, machine shop repair and new OEM parts. We guarantee the best quality parts, the industry's most comprehensive service and the fastest turnaround available at competitive pricing.

Lufkin maintains sales and service centers in key producing regions around the world. These centers are fully equipped and professionally staffed to operate 365 days a year. Our Oilfield Services Group refurbishes and sells used pumping units and provides installation, repair and field maintenance services from the following locations:

- Bakersfield, California
- Denver, Colorado
- Glendive, Montana
- Farmington, New Mexico
- Lovington, New Mexico
- Oklahoma City, Oklahoma
- Andrews, Texas
- Breckenridge, Texas
- Denver City, Texas
- Giddings, Texas
- Kilgore, Texas
- Levelland, Texas
- Odessa, Texas
- Snyder, Texas
- Talco, Texas
- Casper, Wyoming
- Gillette, Wyoming
- Drayton Valley, Alberta
- Medicine Hat, Alberta
- Nisku, Alberta

- Comodoro Rivadavia, Argentina
- Neuquen, Argentina
- Bulimba, Australia
- Cairo, Egypt
- Muscat, Oman

Experienced manufacturing and field service personnel provide a wide-variety of pumping unit services for oil producers around the world including:

- OEM replacement parts for Lufkin, Churchill and American pumping units
- Replacement parts for all brands of pumping units
- Repair or rebuilding damaged pumping units
- Transportation of pumping units to and from field locations
- Inspection and preventive maintenance services
- Manufacturing/supply of portable concrete bases.

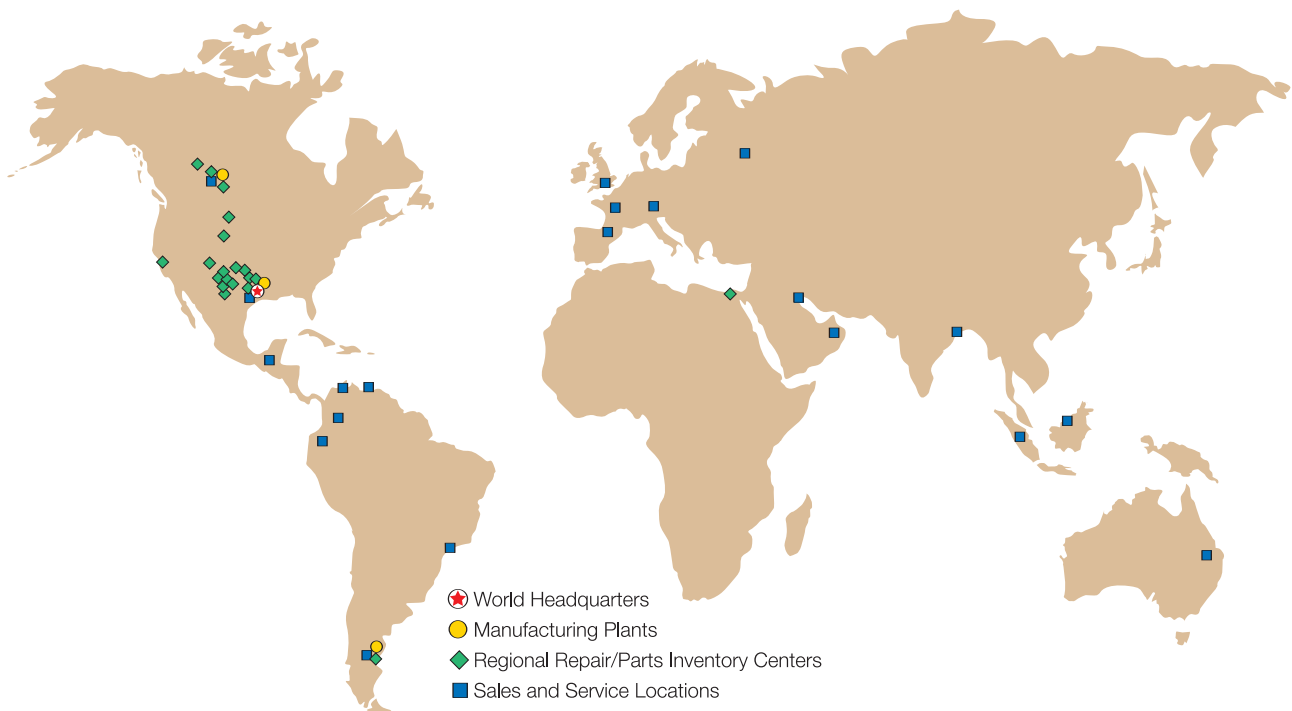

Exclusive OEM Parts for Lufkin, American and Churchill Units

Lufkin Industries is the only source for Lufkin, American and Churchill brand pumping unit OEM parts. Our service centers maintain a complete stock of critical

LUFKIN

AMERICAN
CHURCHILL®

parts. Each center is networked to a centralized manufacturing and inventory control system for quick parts identification, availability and delivery to minimize downtime and production losses. All parts are manufactured to OEM design requirements under the API-Q-1 quality program for which few, if any, local machine shops can qualify.

There are tens of thousands of older Lufkin, American and Churchill units still pumping in fields all over the world. We help keep them running. From bearings, to gears, to structural components, we provide OEM quality backed by expert repair and maintenance services. Additionally, we can machine or fabricate replacement parts for any other brand of rod pump.



Repair Facilities

Lufkin's Oilfield Service Group works on all brands of units. Operating from well-equipped service vehicles, experienced personnel make many repairs on location. For more complicated repairs and equipment testing, our state-of-the-art service facilities are fully equipped to provide necessary machining and fabrication operations.

The development of these regional manufacturing, testing and repair centers has allowed us to provide complete localized service in real time. Customers don't have to wait for our main factory to open to solve a repair or maintenance problem.

Field Service

Lufkin operates a modern fleet of specially equipped tandem winch trucks and cranes designed to provide safe, effective field service on pumping units. To facilitate safe transportation of pumping units to and from field sites, Lufkin maintains a variety of heavy-duty 2-, 3- and 4-axle lowboy trailers.

Our field service capabilities are considered best of class and are unmatched in size, scope and quality. To ensure maximum performance from our customers' wells, our service engineers and technicians are thoroughly trained on all brands of pumping units. Additionally, our Lufkin Automation group has the technology to automate your entire field and to optimize each well's performance.



Service and Parts Guarantee

Lufkin guarantees its products to be free from defects, to fit correctly and to give unmatched performance and reliability when properly installed. Our guarantee exceeds the oilfield industry's standard equipment guarantees.



Pumping Unit Operation and Maintenance Training Schools

Keeping field equipment maintained and operating efficiently is essential to the profitability of oil producers. Lufkin's "Pumping Unit Operation and Maintenance Training School" was first offered in 1987 in response to oil industry demand. This popular training program was developed by industry veterans to specifically teach oilfield production personnel how to keep pumping units properly maintained and operating efficiently. During all instructional sessions, proper safety procedures are stressed.

This 4-day school is conducted at Lufkin Industries' Factory Training Center in Lufkin, Texas. Class sizes are limited in order to permit personalized instruction. Veteran Lufkin employees, who have first-hand experience with the operation and maintenance of oilfield pumping units, conduct all classroom and hands-on sessions which include:

- Setup and operation of a pumping unit
- Counterbalance adjustments
- Lubrication procedures and requirements
- Stroke changes
- Structural bearing assembly and disassembly
- Preventive maintenance procedures
- Safety procedures
- Tour of manufacturing facilities.



Technical calculations for equipment selection are not a regular part of this course, but are available on request.



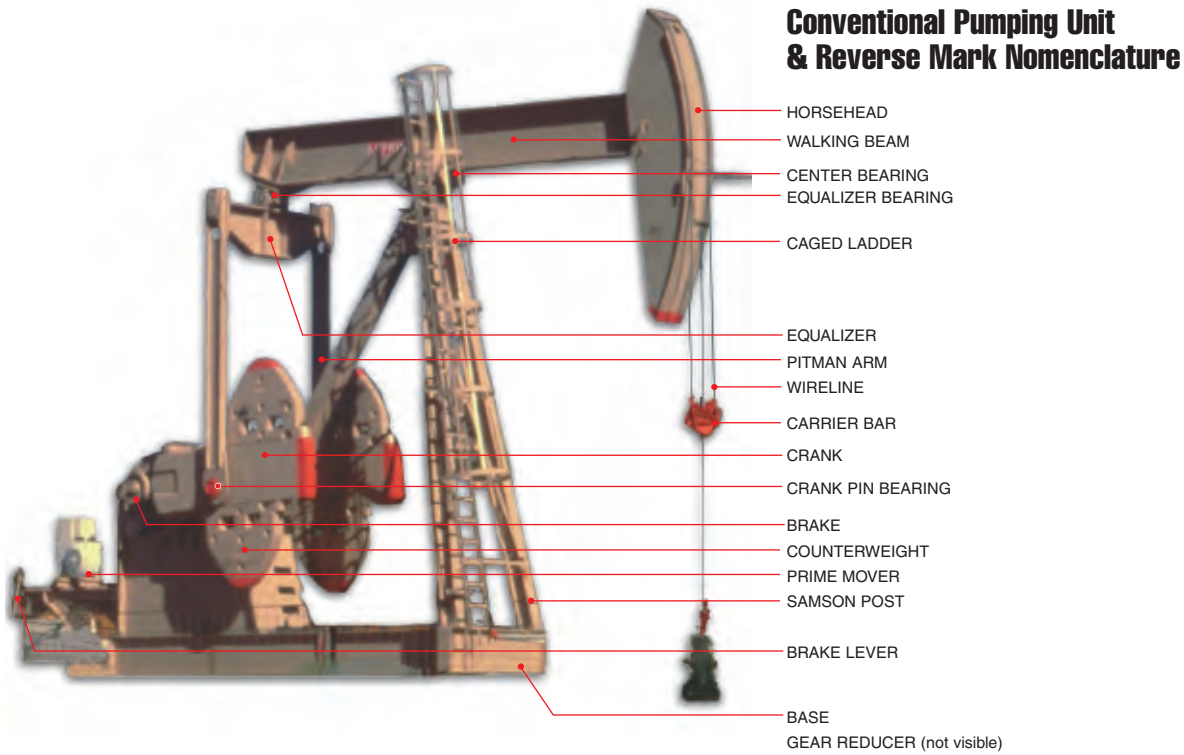

Mark II Pumping Unit Nomenclature

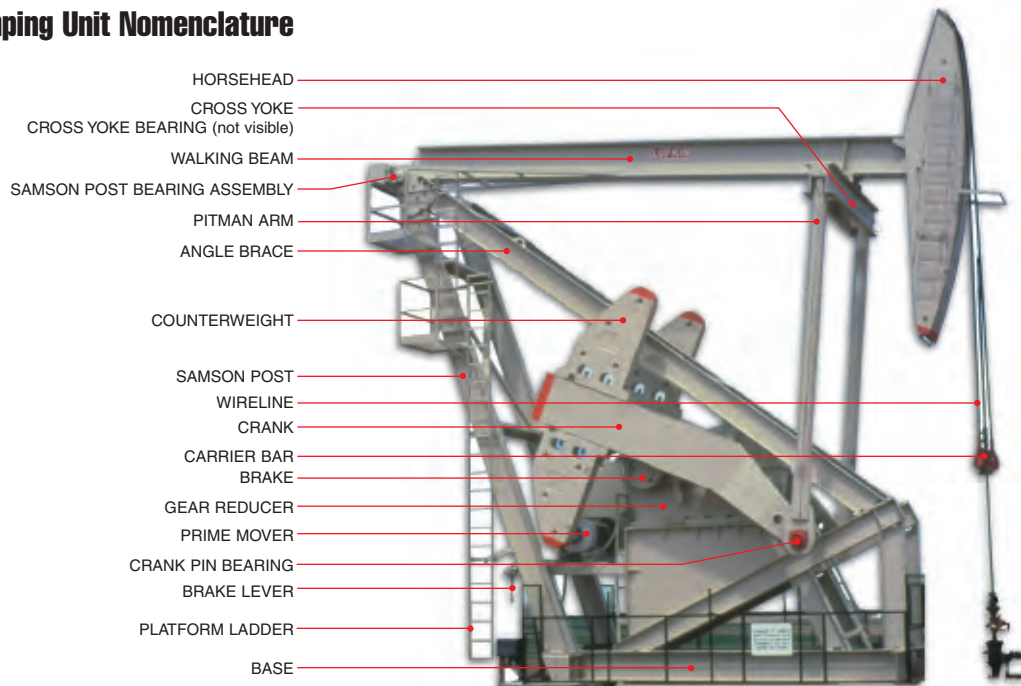

Air Balanced Pumping Unit Nomenclature

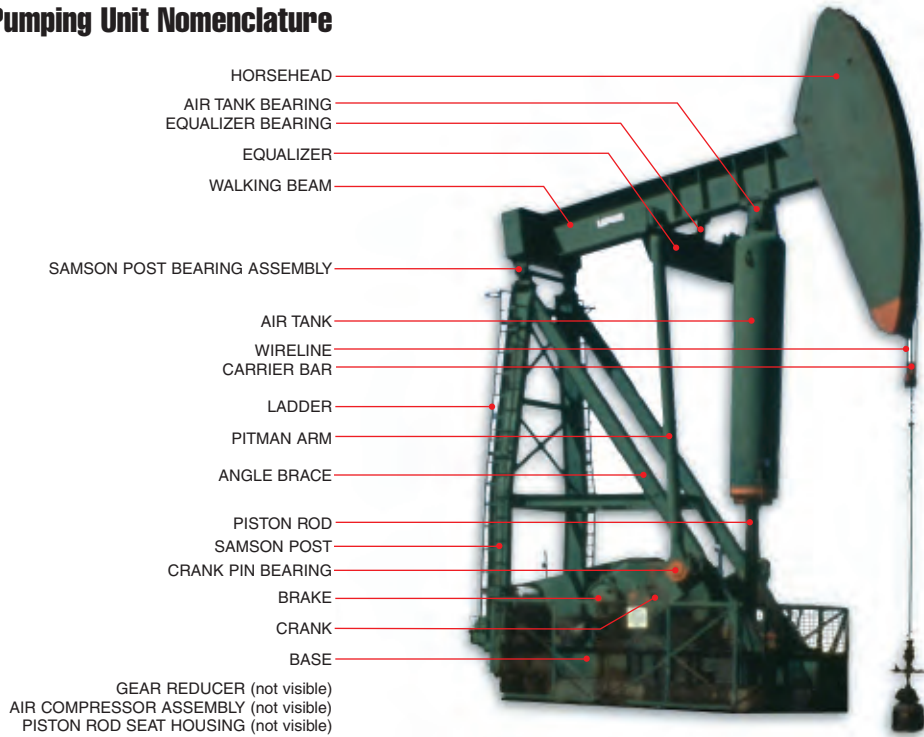

Pumping Unit Model Number Designations

C-228D-246-86

*Type of Pumping Unit _____
 Gear Reducer Peak Torque Rating (thousands of inch lbs.) _____
 Double Reduction Gear Reducer _____
 Polished Rod/Structure Load Rating (hundred lbs.) _____
 Maximum Stroke Length (inches) _____

*Key for Type of Pumping Unit	
A = Air Balanced	M = Mark II Unitorque
B = Beam Balanced	LPII = Low Profile II
C = Conventional	RM = Reverse Mark
CM = Conventional (roadrunner)	LC = Power Lift

Warning

Using repair or replacement parts on any Lufkin Pumping Unit that do not meet Lufkin specifications could result in equipment damage and/or serious injury to personnel near the unit. Before performing maintenance or inspection on any pumping unit, be certain the prime mover is turned-off, locked and tagged in the "off" position; and be certain the cranks are secured against rotation. Any movement of the equipment during maintenance or inspection procedures can cause serious personal injury.

Useful Formulas

Strokes per Minute

Formula:

$$SPM = \frac{RPM}{R} \times \frac{d}{D}$$

Example:

$$SPM = \frac{1170}{30.12} \times \frac{12}{47} = 9.9$$

Where: RPM = 1170 Revolutions per minute of prime mover
R = 30.12 (320D Gear Reducer)
d = 12" Pitch Diameter of Prime Mover Sheave
D = 47" Pitch Diameter of Gear Reducer Sheave

Prime Mover Sheave Diameter

Formula:

$$d = \frac{SPM \times R \times D}{RPM}$$

Example:

$$d = \frac{12 \times 30.12 \times 47}{1170} = 14.5 \text{ inches}$$

Where: SPM = 12 Strokes per Minute
R = 30.12 Ratio (320D Gear Reducer)
D = 47" Pitch Diameter of Gear Reducer Sheave
RPM = 1170 Revolutions per Minute of Prime Mover

Use nearest size available depending upon belt section and number of grooves in sheave.

Belt Velocity

Formula:

$$v = \frac{\pi \times d \times RPM}{12}$$

Example:

$$v = \frac{3.1416 \times 14.5 \times 1170}{12} = 4441 \text{ FPM}$$

Where: d = 14.5 inch Pitch Diameter
RPM = 1170 Revolutions per minute of Prime Mover

Limit between 2000 and 5000 feet per min. (FPM)

Belt Velocity less than 2000 FPM results in poor belt life. Belt Velocity greater than 5000 FPM requires dynamically balanced sheaves.

Center Distance

Formula:

$$CD = \sqrt{\left(U + \frac{V}{2}\right)^2 + (AB - b)^2}$$

Also:

$$\sqrt{\left(UU + \frac{VV}{2}\right)^2 + (AA - b)^2}$$

Example: Assumes Hi-Prime Electric Motor Driven C-320D-256-100 Conventional Unit

$$CD = \sqrt{\left(31 + \frac{33.25}{2}\right)^2 + (54 - 8)^2} = 66.21 \text{ inches}$$

Where: UU = 31 (see General Dimensions)
VV = 33.25 (see General Dimensions)
AA = 54 (see General Dimensions)
b = 8 (assume 25 HP, Frame 324T Motor)

Belt Length

Formula:

$$PL = 2CD + 1.57(D + d) + \frac{(D - d)^2}{4 \times CD}$$

Example:

$$PL = 2 \times 66.21 + 1.57(47 + 14.5) + \frac{(47 - 14.5)^2}{4 \times 66.21} = 232.96 \text{ inches}$$

Where: CD = 66.21 inch Center Distance of Shafts
D = 47 inch Pitch Diameter of Gear Reducer Sheave
d = 14.5 inch Pitch Diameter of Prime Mover Sheave

Use nearest belt size available depending on type of sheaves selected.

Horsepower of Prime Mover (these values are approximate)

Formula A:

$$HP = \frac{BPD \times \text{Depth}}{56000}$$

Formula B:

$$HP = \frac{BPD \times \text{Depth}}{45000}$$

Example: Assumes high slip (Nema D) motor.

$$HP = \frac{217 \times 5600}{56000} = 21.7 \text{ (use 25 HP motor)}$$

Where: BPD = 217 @ 100% pump efficiency
Depth = 5600 feet, pump setting

Formula A: for high slip (Nema D) electric motors and slow speed engines.
Formula B: for normal slip electric motors and multi-cylinder engines.

Multiply HP by 0.8 for Mark II units.

Maximum Strokes per Minute (based on the free fall speed of the rod)

Formula:

Conventional Units: Air Balanced Units: Mark II Units:

$$SPM = .7 \sqrt{\frac{60000}{L}} \quad SPM = .63 \sqrt{\frac{60000}{L}} \quad SPM = .56 \sqrt{\frac{60000}{L}}$$

Example: Assumes a C-320D-256-100 Conventional Unit.

$$SPM = .7 \sqrt{\frac{60000}{100}} = 17.15 \text{ SPM Maximum}$$

Definition of Symbols Used

SPM = Strokes per Minute	V = see General Dimensions
RPM = Revolutions per Minute of Prime Mover	AB = see General Dimensions
FPM = Feet per Minute	UU = see General Dimensions
R = Gear Reducer Ratio	VV = see General Dimensions
D = Gear Reducer Sheave Pitch Diameter, inches	AA = see General Dimensions
d = Prime Mover Sheave Pitch Diameter, inches	b = Prime Mover Backing (vertical distance from mounting feet to center of shaft), inches
v = Belt Velocity, Feet per Minute	HP = Horsepower
π = 3.1416 (Pi)	BPD = Barrels per Day at 100% Pump Efficiency
PL = Belt Pitch Length, inches	Depth = Pump Setting, feet
CD = Shaft Center Distance, inches	L = Stroke Length, inches
U = see General Dimensions	

ORDERING INSTRUCTIONS AND WARRANTIES

ORDERING INSTRUCTIONS

To size and/or order a Lufkin pumping unit, contact the nearest Lufkin representative or sales office. When ordering replacement parts, be sure to include the unit model number, unit serial and order number, a complete part description and, if known, the casting number or part number.

LIMITED WARRANTY*

ALL NEW LUFKIN INDUSTRIES, INC. ("LUFKIN") oilfield machinery and equipment ("products") are sold by LUFKIN or its dealer upon the following warranty and agreement given by LUFKIN or its authorized dealer. THE WARRANTIES SET FORTH ARE EXCLUSIVE AND IN LIEU OF ALL OTHER WARRANTIES AND CONDITIONS WHETHER STATUTORY, EXPRESS OR IMPLIED, INCLUDING WARRANTIES OF MERCHANTABILITY, FITNESS FOR A PARTICULAR PURPOSE, AND WARRANTIES ARISING FROM COURSE OF DEALING, USAGE, OR TRADE and are exclusive and in lieu of any other obligation on the part of LUFKIN or its authorized dealer. LUFKIN neither assumes nor authorizes any person to assume for it any other liability in connection with the sale of such products. The obligation of LUFKIN or its authorized dealer under this warranty, is limited to the following:

LUFKIN warrants to the ORIGINAL PURCHASER ("PURCHASER") of the pumping unit, subject to the conditions herein stated, that the pumping unit shall be, upon delivery, free from manufacturing defects. This Warranty shall run for a period of five (5) years from the date of shipment from LUFKIN's plant. In the event the pumping unit fails to operate properly due to a manufacturing defect (or) a manufacturing defect is discovered during the warranty period, LUFKIN shall only be obligated to repair or replace the pumping unit, at LUFKIN's option, free of charge, F.O.B. LUFKIN's plant, or other designated place of repair or replacement. Repair or replacement by LUFKIN shall not extend the warranty period. LUFKIN will have no liability under this Warranty unless LUFKIN receives written notice from PURCHASER of the defect within thirty (30) days after discovery of the defect. LUFKIN may waive the requirement of written notice and accept oral notice of a timely reported defect. LUFKIN shall not be liable under this Warranty and this Warranty will be null and void if the pumping unit, or any part thereof, was damaged, subjected to abuse, altered, misused or if the pumping unit, or any part thereof was improperly stored, installed, maintained, repaired or operated. Repair or replacement of the pumping unit, or any part thereof, shall fulfill all obligations of LUFKIN. The Warranty provided in this paragraph is subject to the following exceptions.

LUFKIN's warranty is limited to one (1) year (subject to the terms and conditions stated above) with respect to parts that are subject to wear under normal operating conditions (including, but not limited to contact type oil or grease seals, hoses, belts, elastomeric parts, wireline, brake lining, brake cables, etc.).

LUFKIN extends no warranties with respect to the design of the pumping unit or the component parts, materials or accessories manufactured, furnished or supplied by individuals or entities other than LUFKIN (including, but not limited to prime movers, compressors, valves, electrical components, etc.). LUFKIN agrees that any warranty which is given to LUFKIN on such components by the manufacturer thereof shall be extended to the PURCHASER but only to the extent permitted by the terms of such warranties.

The remedies provided above are the exclusive remedies of PURCHASER for failure of LUFKIN to meet its warranty obligations, whether claims of PURCHASER are based on contract, in tort (including negligence) or otherwise. Upon expiration of the applicable warranty period, all obligations of LUFKIN for breach of warranty will terminate. The provisions of this Warranty shall be governed in accordance with the laws of the State of Texas.

Subject to and without waiving the foregoing, Purchaser agrees that neither LUFKIN, nor its affiliates, vendors, suppliers, agents, or subcontractors, either individually or jointly, shall be liable to PURCHASER, its affiliates, or any other person or entity whether due to LUFKIN's negligence or otherwise, and will not be responsible to PURCHASER in contract, in tort (including negligence) or otherwise for loss of use of equipment or plant, loss of profits or revenues, claims of any customers of PURCHASER, or any special, indirect, incidental or consequential loss of damage whatsoever. The obligation of LUFKIN arising out of the work performed hereunder, will be limited to remedies under the limited warranty set forth above. IN NO EVENT SHALL THE PURCHASER OR ANY OTHER PERSON OR ENTITY BE ENTITLED TO RECOVER FOR INDIRECT, SPECIAL, EXEMPLARY, INCIDENTAL OR CONSEQUENTIAL DAMAGES, INCLUDING BUT NOT LIMITED TO INCONVENIENCE, RENTAL OF REPLACEMENT EQUIPMENT, LOSS OF PROFITS OR OTHER COMMERCIAL OR ECONOMIC LOSS.

PURCHASER agrees to protect, defend, indemnify and save LUFKIN, its subcontractors and affiliates and their employees performing services under this Agreement harmless from and against all liabilities, loss, expense, claims, demands, and causes of action of every kind and character arising out of or in connection with this Agreement, or the work to be performed hereunder, without limit and without regard to the cause or causes of action thereof OR THE NEGLIGENCE OF ANY PARTY OR PARTIES, INCLUDING LOSSES ATTRIBUTABLE TO LUFKIN'S NEGLIGENCE, arising in connection herewith in favor of PURCHASER or third parties on account of bodily injury, death or damage to property.

PURCHASER agrees that whenever any representative of LUFKIN shall be on the premises of PURCHASER or at any place other than LUFKIN's facility, for the purpose of inspecting, repairing or servicing of the equipment sold herewith, the PURCHASER shall indemnify and hold LUFKIN harmless from all claims, suits or actions arising from or growing out of the inspecting, repairing or servicing of such equipment and from all expenses of defending against such claims, suits or actions.

PURCHASER acknowledges and agrees, on its own behalf and on the behalf of its assigns and successors, that the Texas Deceptive Trade Practices—Consumer Protection Act, Subchapter E of Chapter 17 of the Texas Business and Commerce Code (the "DTPA"), is not applicable to this transaction. As such, PURCHASER's and LUFKIN's rights and remedies with respect to this transaction, and with respect to all acts or practices of the other, past, present or future, in connection with this transaction, shall be governed by legal principles other than the DTPA. Accordingly, PURCHASER acknowledges and agrees as follows:

PURCHASER HEREBY IRREVOCABLY WAIVES, TO THE FULL EXTENT PERMITTED BY LAW, ANY AND ALL RIGHTS AND CLAIMS THAT PURCHASER MAY NOW HAVE, OR TO WHICH IT MAY OTHERWISE IN THE FUTURE HAVE BEEN ENTITLED, UNDER THE TEXAS DECEPTIVE TRADE PRACTICES—CONSUMER PROTECTION ACT, TEX. BUS. AND COM. CODE § 17.41 ET SEQ., ("DTPA"), ARISING OUT OF ANY ACT, CONDUCT, REPRESENTATION OR OMISSION OF LUFKIN, ITS EMPLOYEES OR AGENTS, HERETOFORE OR HEREAFTER TAKEN, DONE OR OMITTED TO BE DONE IN CONNECTION WITH THIS TRANSACTION OR SUBSEQUENT RELATED TRANSACTIONS.

**This Limited Warranty does not apply to the Churchill pumping unit or Lufkin Automation product lines. For information on the Churchill warranty, see page 40. For information on the Lufkin Automation warranty, refer to www.lufkinautomation.com.*



LUFKIN

Visit www.Lufkin.com to find your nearest Lufkin support location,
or email us at oilfield@lufkin.com.



OF11-0015-R00
©2011 Lufkin Industries, Inc.
All rights reserved.

WWW.LUFKIN.COM