

RIGMASTER 80 PUMPING UNITS



RigMaster, Inc.

HOUSTON OFFICES P.O. Box 19801 Houston, Texas 77024 Phone 713-467-4660
PLANT 807 Bohlmann Avenue Schulenburg, Texas 78956 Phone 713-743-4107



RIGMASTER API PUMPING UNITS

SERIES 80 SIZE 320

320,000 INCH POUND PEAK TORQUE REDUCERS

STRUCTURE DATA

Structure Size	305-100	256-120	213-120
Unit Designation	320-305-100	320-256-120	320-213-120
Structure Capacity, Lbs.	30,500	25,600	21,300
Length of Stroke, In.	100-90-80	120-110-100	120-110-100
Walking Beam Size	27 x 146#	27 x 146#	24 x 131#
Saddle Bearing Pt. No.	RM 28124	RM 28124	RM 28124
Tailbearing Pt. No.	RM 32158	RM 32158	RM 32158
Wrist Pin Bearing Pt. No.	RM 32150	RM 32150	RM 32150
Pitman Size	3 1/2" x Sch. 80 Pipe	3 1/2" x Sch. 80 Pipe	3 1/2" x Sch. 80 Pipe
Wire Line Hanger	1 1/4" x 12" Ctrs.	1 1/4" x 12" Ctrs.	1 1/4" x 12" Ctrs.
Cranks	71035	71035	71035
Net Structure Unbalance	+ 813	+ 276	+ 284

GEAR REDUCER DATA

Reducer Size	320
Peak Torque @ 20 S.P.M.	320,000 In. Lbs.
Gear Ratio, Double Reduction	30.266:1
Crankshaft Diameter	6 1/2; Key - 1 1/2 x 1 1/2 x 7 1/2 Lg.
V-Belt Sheave Outside Diameter	Std. - 44" 4G4C
Diameter of Reducer High Speed Shaft	3"; Key - 3/4 x 3/4 x 4 1/2 Lg.
Gear Reducer Oil Capacity, U.S. Gal.	37

OPTIONAL

Wide Main Base (Portable Type).

Power Assemblies for: Single Cylinder Engines, Hi Speed Engines, Electric Motors, Elevated or Ground Level.

Crank Guard Rails

Two Tone Paint.

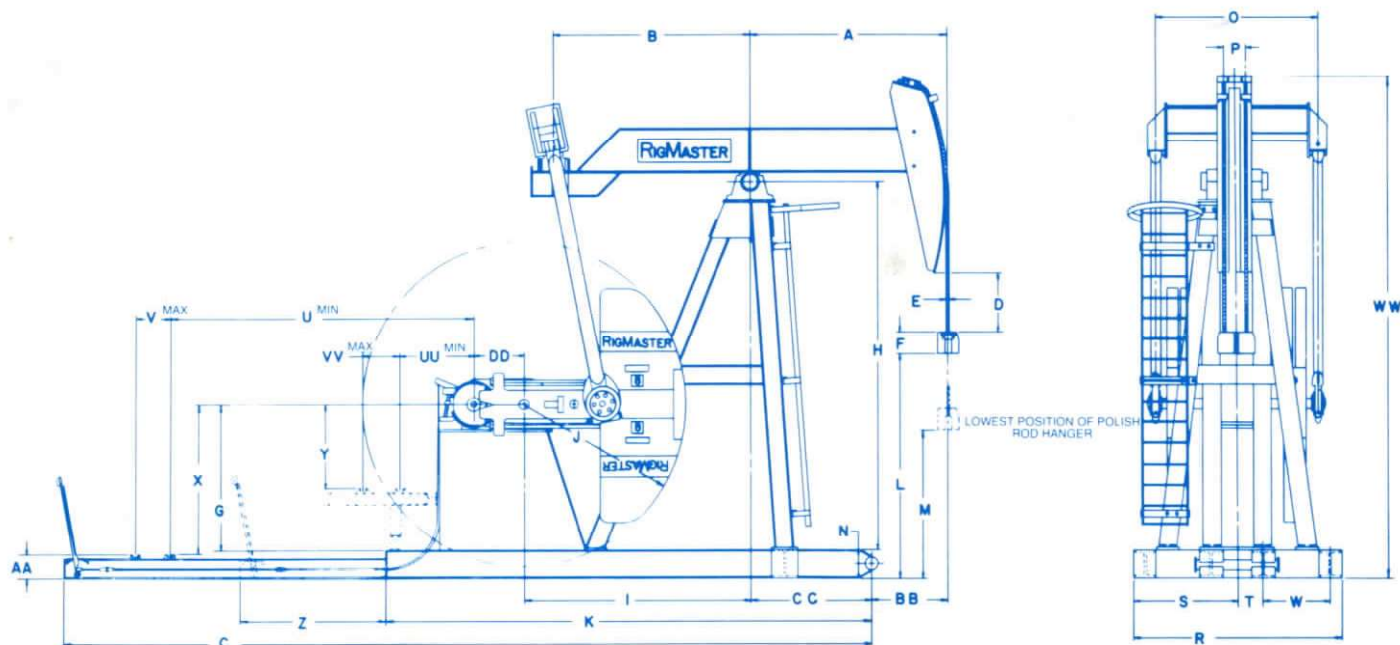

Model	A	B	C	D	E	F	G	H	I	J	K	L	M	N	O	P	R	S	T	U	V	W	X	Y	Z	AA	BB	CC	DD	UU	VV	WW	XX
320-305-100	11'-0 1/2"	10'-9"	32'-4 3/4"	16 9/16"	1 1/4"	9 1/8"	83"	15'-5 3/4"	140 1/4"	92"	21'-4"	9'-23 1/16"	4'-5 9/16"	13 3/8"	79 7/8"	12"	96'-48"	16'-84 3/4"	79 9/16"	28"	78 9/16"	56 11/16"	24 1/2"	18 1/16"	94 3/4"	36 1/4"	34 1/8"	17 1/16"	43 13/16"	23'-0 3/8"			
320-256-120	13'-1 1/4"	10'-9"	32'-4 3/4"	17 13/16"	1 1/4"	9 1/8"	83"	15'-5 3/4"	140 1/4"	92"	21'-4"	9'-1"	3'-5 11/16"	13 3/8"	79 7/8"	12"	96'-48"	16'-84 3/4"	79 9/16"	28"	78 9/16"	56 11/16"	24 1/2"	18 1/16"	121"	36 1/4"	34 1/8"	17 1/16"	43 13/16"	23'-0 3/8"			
320-213-120	13'-1 1/4"	10'-9"	32'-4 3/4"	17 13/16"	1 1/4"	9 1/8"	83"	15'-5 3/4"	140 1/4"	92"	21'-4"	9'-1"	3'-5 11/16"	13 3/8"	79 7/8"	12"	96'-48"	16'-84 3/4"	79 9/16"	28"	78 9/16"	56 11/16"	24 1/2"	18 1/16"	121"	36 1/4"	34 1/8"	17 1/16"	43 13/16"	23'-0 3/8"			